

IND  
34490

# NATIONAL LAMP<sup>®</sup> DOON

APRIL 1976

THE HUMOROUS MAGAZINE

\$1.00



# SPORTS

# TALL

Towers over ordinary  
120s

TALL is not an ordinary 120.  
TALL has more tobacco than other white  
120s. So it's firm and full. With TALL,  
you've really got hold of something.

Tall  
white  
and  
handsome

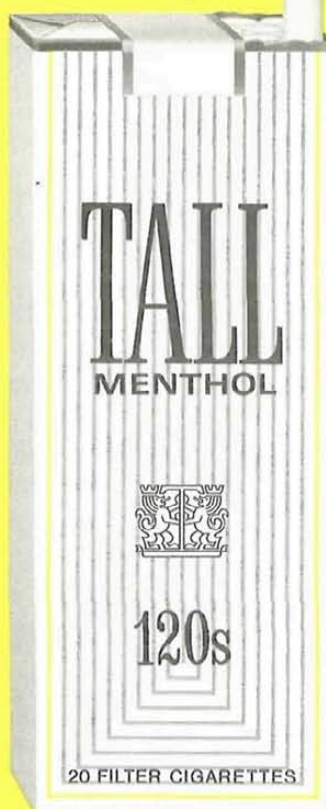
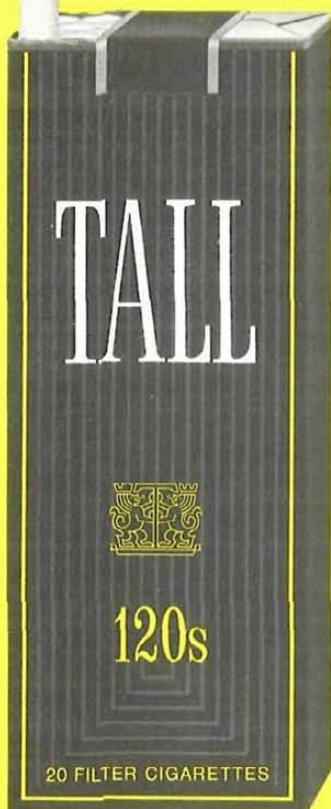

**Not just extra puffs but extra tobacco.  
And costs no more than 100s.**

Warning: The Surgeon General Has Determined  
That Cigarette Smoking Is Dangerous to Your Health.

Filter: 20 mg. "tar", 1.5 mg. nicotine; Menthol: 18 mg. "tar", 1.6 mg. nicotine av. per cigarette by FTC method.

Copyright © 2007 National Lampoon Inc.

# What's the world come to when a backseat is considered optional equipment?



**The 1976 Chevette.  
The new idea from Detroit.**

As incredible as it may seem, on the 1976 Chevette Scooter, for your \$2,899,\* you don't get a backseat. You get a space where a backseat could go. If you want a backseat, it costs you an extra \$199.

It's part of a trend in the auto industry. Things that people once considered important to the design and safety of a car are now considered luxuries.

On many cars, radial-ply tires are now optional. Padded steering wheels are optional. Power-assisted brakes are optional. Even day/night rearview mirrors are optional.

And many of the things that make a car look better are anything but standard.

For example, on the standard VW Rabbit, armrests, vinyl interior trim and vinyl seats, and bright metal exterior trim, and carpeting are yours. But only at extra cost. They've even left off the rubber pads on the brake and gas pedals. Those are optional, too.

On the standard Chevette Scooter, the door panels are embossed cardboard and the bumpers and hubcaps aren't aluminum or chrome. They're metal painted gray.

Why are we telling you this?

Because even today a few cars still give you a great deal of standard equipment for your money. And we're happy to say one of them is Fiat.

On the standard Fiat 128, our least expensive model, the door panels are vinyl not cardboard. The seats are vinyl instead of cloth. The bumpers are aluminum and rubber instead of painted metal. There are front door armrests. Passenger-assist handles. An electric windshield washer. A day/night rearview mirror. All standard.

Radial-ply tires, which cost \$100 to \$200 extra on many cars, are standard on the Fiat. Power-assisted front disc brakes are standard. Rack-and-pinion steering is standard.

And then you get things standard on the Fiat you couldn't get on most cars even as options: front-wheel drive, 4-wheel independent suspension, a transverse-mounted overhead cam engine.



**Instead of a long list of options we  
give you a long list of standards.**

Now that you know all this, we hope that when you go out to buy a car you'll take the time to figure out the real price of the car, the price that includes everything you want on it. And that you won't fall for the stripped-down price on the sticker. It will save you a fortune. And it's been known to make us a few customers.

**FIAT**

**A lot of car. Not a lot of money.**

\*1976 Manufacturer's suggested retail price POE. Inland transportation, dealer preparation and local taxes additional. Fiat car rental, leasing, and overseas delivery arranged through your dealer.

# PIONEER HAS DEVELOPED A RECEIVER EVEN THE COMPETITION WILL ADMIT IS THE BEST.

One look at the new Pioneer SX-1250, and even the most partisan engineers at Marantz, Kenwood, Sansui or any other receiver company will have to face the facts.

There isn't another stereo receiver in the world today that comes close to it. And there isn't likely to be one for some time to come.

In effect, these makers of high-performance receivers have already conceded the superiority of the SX-1250.

Just by publishing the specifications of their own top models.

As the chart shows, when our best is compared with their best there's no comparison.

To begin with, the SX-1250 is at least 28% more powerful than any other receiver ever made. Its power output is rated at 160 watts per channel minimum RMS at 8 ohms from 20 to 20,000 Hz, with no more than 0.1% total harmonic distortion.

And, for critical listening, no amount of power is too much. You need all you can buy.

To maintain this huge power output, the SX-1250 has a power supply section unlike any other receiver's, with a large toroidal-core transformer and four giant 22,000-microfarad electrolytic capacitors.

But power isn't the only area in which the SX-1250 excels. The preamplifier circuit has an unheard-of phono overload level of half a volt (500 mV). This means that no magnetic cartridge in the world can drive the preamp to the point where it sounds strained or hard. And the equalization for the RIAA recording curve is accurate within

$\pm 0.2$  dB. A figure unsurpassed by the costliest separate preamplifiers.

Turn the tuning knob of the SX-1250, and you'll know at once that the AM/FM tuner section is also special. The tuning mechanism feels astonishingly smooth, precise and solid.

FM reception is loud and clear even on weak FM stations because the tuner combines extremely

high sensitivity with highly effective rejection of spurious signals.

Of course, the Pioneer SX-1250 carries a price tag commensurate with its position at the top. But if you seek perfection you won't mind paying the price.

If, on the other hand, you'd mind, look

into the new Pioneer SX-1050 or SX-950. They're rated at 120 and 85 watts, respectively, per channel (under the same conditions as the SX-1250) and their design is very similar. In the case of the SX-1050, virtually identical.

That means you don't just come to Pioneer for the world's best.

You also come to us for the next best.

For informational purposes only, the SX-1250 is priced under \$900. The actual resale price will be set by the individual Pioneer dealer at his option.

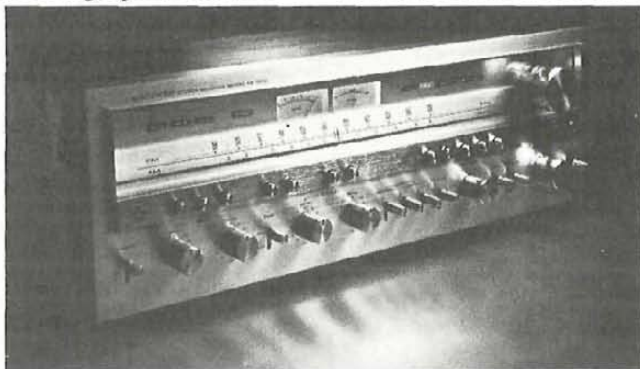

**PIONEER®**  
Anyone can  
hear the difference.

U.S. Pioneer Electronics Corp., 75 Oxford Drive, Moonachie, New Jersey 07074.

	PIONEER SX-1250	MARANTZ 2325	KENWOOD KR-9400	SANSUI 9090
POWER, MIN. RMS. 20 TO 20,000 HZ.	160W+160W	125W+125W	120W+120W	110W+110W
TOTAL HARMONIC DISTORTION	0.1%	0.15%	0.1%	0.2%
PHONO OVER- LOAD LEVEL	500 mV	100 mV	210 mV	200 mV
INPUT: PHONO/AUX/MIC	2/1/2	1/1/no	2/1/mixing	1/1/mixing
TAPE MON/DUPL.	2/yes	2/yes	2/yes	2/yes
TONE	Twin Tone: Bass-Bass- Treble-Treble	Bass-Mid- Treble	Bass-Mid- Treble	Bass-Mid- Treble
TONE BYPASS	Yes	Yes	Yes	Yes
SPEAKERS	A,B,C	A,B	A,B,C	A,B,C
FM SENSITIVITY (IHF '58)	1.5 $\mu$ V	1.8 $\mu$ V	1.7 $\mu$ V	1.7 $\mu$ V
SELECTIVITY	90 dB	80 dB	80 dB	85 dB
CAPTURE RATIO	1.0 dB	1.25 dB	1.3 dB	1.5 dB

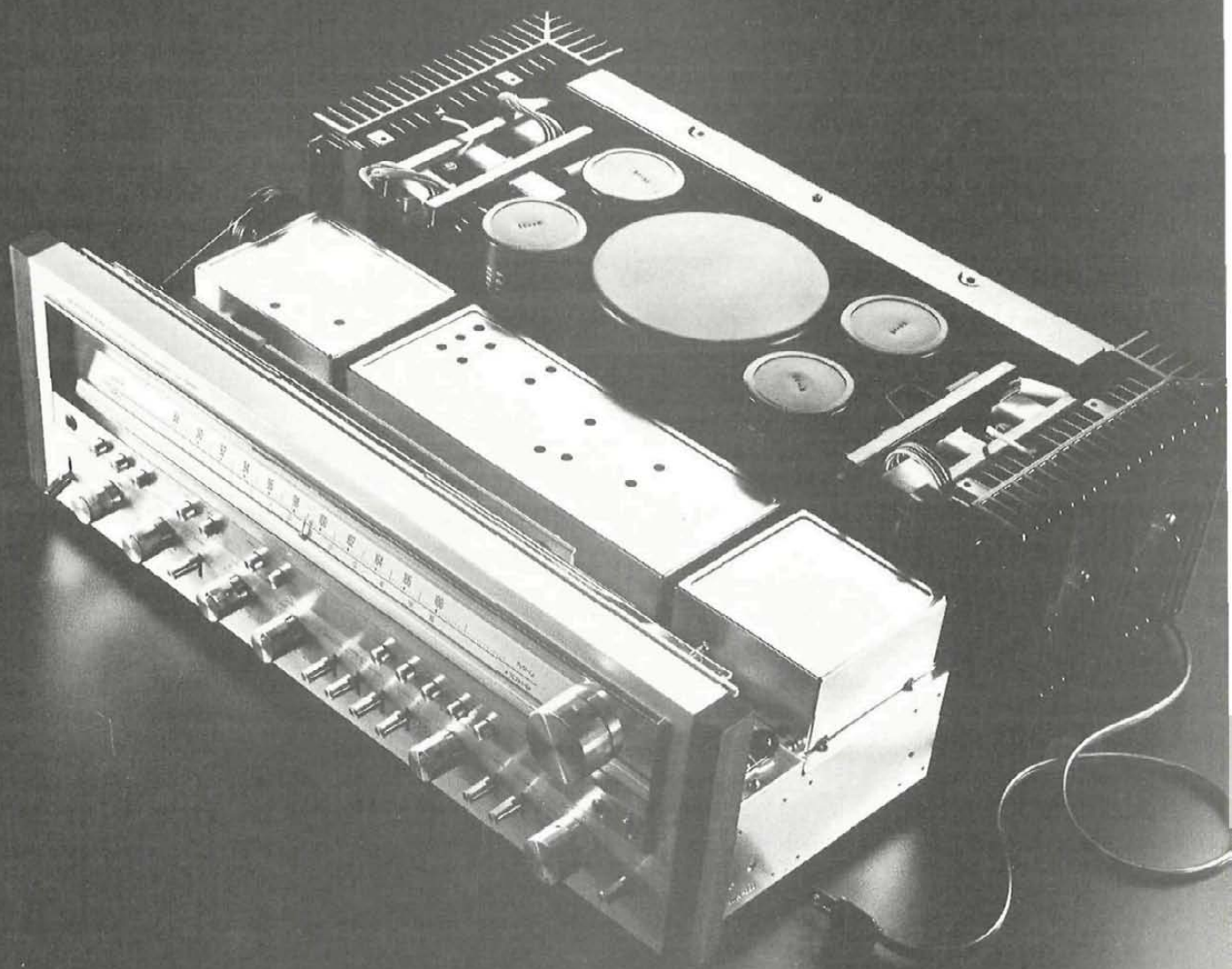

# THE NEXT ONE:



DESTROYER NBLP 7025

## THE LIVE ONE!



ALIVE! NBLP 7020-798



DRESSED TO KILL NBLP 7016

## THE ORIGINALS:



HOTTER THAN HELL NBLP 7006



KISS NBLP 7001

**A rock steady**  
PRODUCTION INC.

PRODUCED BY BOB EZRIN

AVAILABLE ON  
**Casablanca**  
RECORDS & TAPES

# "I challenge you to break my World Record for the most miles traveled by bus in 30 days."



"The Guinness World Record for the most miles traveled by bus in 90 days is 17,104 miles. But who has the money to ride a bus for 90 days?"

So I established my own World Record: 12,147 miles in 30 days.

You say, there's a record I could get my teeth into, but not my wallet. Still no problem.

Trailways offers a number called Eaglepass: 30 days of unlimited travel for \$175, 60 days for \$250. How many guys have become living legends for a measly 1.444068 cents a mile?

Other companies have similar deals, but I chose a Trailways bus for its great ride, comfortable seats, and you know what else? Mother says they have clean toi-tois.

America is waiting for a new breed of red-blooded, two-fisted adventurer who will accept my challenge. Can you cut the ketchup? If so, give your travel agent a ring. Or mail the coupon. This could just be your first step to immortality."

- I accept your challenge, but not your shorts. Send me more information on Eaglepass.
- I'm crazy about travel, but not that crazy. Just send me more information on Eaglepass.

Name \_\_\_\_\_

Address \_\_\_\_\_

City \_\_\_\_\_ State \_\_\_\_\_ Zip \_\_\_\_\_

Mail to: Trailways Eaglepass, 2805 Logan St.,  
Dallas, Texas 75215

NL 4/76

**Trailways**  
**THE BEST BUS GOING.**

# ACTUAL SIZE CONTENTS PAGE



**Chrissie's Clit**

**Sportbiz News, 35**  
Gerald Sussman, Tony Hendra,  
Peter Kaminsky and Chris Cerf  
**Dogfishing, 41**  
By Gerald Sussman,  
photography by Matthew Klein  
**Silver Jock, 47**  
By R. Bruce Moody and Gerald Sussman

**Valley Heights High, 57**  
By P.J. O'Rourke  
**The Glory of Their Hindsight, 60**  
By Bruce McCall

**U.S. Olympic Handbook, 63**  
By Peter Kaminsky  
**Sports Comeback of the Year, 69**  
By Gerald Sussman, illustrated by Rick Meyerowitz

**Surprise Poster, 74**  
By Don Ivan Punchatz  
**The Puck Stops Here, 87**  
By Aislin

## FILLER

**Editorial, 8**  
**Letters, 10**  
**Bernie X, 16**  
**The National, 21**  
**True Facts, 28**  
**Foto Funnies, 56, 76**  
**Funny Pages, 77**



**Nastase's Fangs**



**Cosell's  
Heart**



**Clyde's  
Cup**



**Bradshaw's Brain**

**NATIONAL LAMPOON® MAGAZINE:** "National Lampoon" is a registered trademark of National Lampoon, Inc. The Lampoon name is used with the permission of the Harvard Lampoon, Inc. Copyright © 1976, National Lampoon, Inc., 635 Madison Avenue, New York, N.Y. 10022. All rights reserved. Nothing may be reprinted in whole or in part without written permission from the publisher. Any similarity to real people and places in fiction and semi-fiction is purely coincidental. **SUBSCRIPTIONS:** Published monthly by National Lampoon, Inc., 635 Madison Avenue, New York, N.Y. 10022. \$7.95 paid annual subscription, \$13.25 paid two-year subscription, and \$18.00 paid three-year subscription in territorial U.S. Additional \$1.00 for Canada and Mexico. \$2.00 for foreign. Second-class postage paid at New York, N.Y., and additional mailing offices.

**CHANGE OF ADDRESS:** Subscriber please send change of address to Circulation Manager, National Lampoon Magazine, 635 Madison Avenue, New York, N.Y. 10022. Be sure to give old address, new address, and zip code for both. Allow six weeks for change. **POSTMASTER:** Please mail Form 3579 notices to: Circulation Manager, National Lampoon Magazine, 635 Madison Avenue, New York, N.Y. **ADVERTISING INFORMATION:** Contact Advertising Director, National Lampoon Magazine, 635 Madison Avenue, New York, N.Y. 10022, or call (212) 688-4070. **EDITORIAL INFORMATION:** Contact Submissions Editor, National Lampoon Magazine, 635 Madison Avenue, New York, N.Y. 10022, or call (212) 688-4070. Return postage must accompany all manuscripts, drawings, and photographs submitted if they are to be returned. Publisher assumes no responsibility for unsolicited material.



# If you've got the salt, I've got the Sauza.

Nothing gets a good thing going better than Tequila Sauza. That's because Sauza is the Número Uno Tequila in all of Mexico. And that's because Tequila Sauza—Silver or Gold—does best all the things anybody would want Tequila to do.

Try it the classic down-Mexico way: in a shot glass, with salt and lime on the side. Or in a Margarita. Or in a Sunrise. Who knows where it will all lead?



Tequila 80 Proof. Sole U.S. Importer. National Distillers Products Co., N.Y.

Copyright © 2007 National Lampoon Inc.



# EDITORIAL

It was 1946. The war had been over for a year. America was returning to normalcy. Cars were rolling off the assembly line. Refrigerators, washers, dryers, and air conditioners were being built as fast as hand and machine could make them. A new device called television promised to open a fantastic world of entertainment and culture. America boomed with energy as it converted its mighty war machine into peacetime uses. And part of this incredible energy poured into sports.

The sports heroes returned from the wars. Thousands of service veterans returned to high school, college, and the professional ranks. Baseball, football, basketball, track and field, and many other sports skyrocketed to greater glories. Everywhere you went you heard the joyous thud of footballs being kicked, the happy thwack of baseballs being hit. And deep in that joyous, happy activity was a boy of fourteen, growing up in the streets of Brooklyn, dreaming of becoming an-

other Johnny Lujack, another Joe DiMaggio. He was short and slight of build, but was determined to make his high school teams. He ran miles, he ran wind sprints, he lifted weights, and went on strange diets to increase his weight. More than anything, he wanted to make the football team.

His persistence was rewarded. The youngster made the team, though just barely. He was a scrub, a benchwarmer—but an eager, fearless tackler and blocker, despite his diminutive size. Then one day he complained of strange pains in his legs and arms. He was rushed to the hospital where his ailment was diagnosed as polio. There were no Salk or Sabin vaccines in those days.

The young man lost the use of his arms and legs. But he wouldn't give up. He knew of others who had fought back from this dread disease and lived to play their beloved games again. And so he doubled and tripled his efforts to rebuild his limbs. He exercised

patiently, tirelessly, year after year. His chums at high school went on to become famous athletes. Some came to encourage and inspire him. And he continued to work at his goal.

But, at the age of twenty-one, he was told that his condition was hopeless. He could never regain any use of his limbs. He would never be a star athlete. He would never be anything. And so he lay there in his wheelchair and cried for six days and six nights. And on the seventh day he went into a coma. His overpowering love of sports did him absolutely no good. He was a cripple and a failure.

Some will say this story is false, that it never happened. But I say that it did happen, because that boy was me. And my story is far more typical than the success stories inspired by devotion to sports. Sports taught me one important lesson: no amount of will, determination, and inspiration can overcome a hopeless medical problem.

— G.S.

Editors: **Tony Hendra, Sean Kelly, Douglas Kenney** Managing Editor: **P.J. O'Rourke**

Associate Editors: **John Weidman, Gerald Sussman** Art Director: **Peter Kleinman**

Staff Writers: **Peter J. Kaminsky, Ted Mann**

Senior Copy Editor: **Louise Gikow** Projects Copy Editor: **Susan Devins**

Associate Art Directors: **Mark Hecker, Diana Feldman** Photo Editor: **Pedar Ness**

Art Associates: **Lisa Lenovitz, Skip Johnston** Assistant to the Art Director: **Phyllis Epstein**

Submissions Editor: **Julie Simmons** Staff Assistant: **Wendy Mogel**

Contributing Editors: **Christopher Cerf, Bruce McCall, Chris Miller, R. Bruce Moody, Emily Prager, Marc Rubin, Ed Subitzky**

Contributing Artists: **Neal Adams, Arky & Barrett, M.K. Brown, Gil Eisner, Randall Enos, Shary Flenniken, Dick Frank, Matthew Goldman, Ronald C. Harris, Bobby London, Stan Mack, Mara McAfee, Wayne McLoughlin, Rick Meyerowitz, Ralph Reese, Charles Rodrigues, Alan Rose, Norman Rubington, Warren Sattler, Neil Selkirk, Gahan Wilson**

Production Manager: **George Agoglia, Jr.** Press Relations: **Janis Hirsch**

Publisher: **Gerald L. Taylor**

The National Lampoon, Inc. is a subsidiary of Twenty First Century Communications, Inc.

Chairman: **Matty Simmons** President: **Leonard Mogel**

Sr. Vice-President, Administration: **George Agoglia** Sr. Vice-President, Sales: **Gerald L. Taylor**

Vice-President, Finance: **Charles Schneider** Vice-President, Subscriptions and Product Sales: **Howard Jurofsky**

Advertising Offices, New York: William T. Lippe, Advertising Director, Herman Brown, Jr., Account Executive,

National Lampoon, 635 Madison Ave., New York, N.Y. 10022, (212) 688-4070.

Chicago: William H. Sanke, Midwest Advertising Director, 360 N. Michigan Ave., Chicago, Ill. 60601, (312) 346-7145.

West Coast: Lowell Fox, 10960 Wilshire Blvd., Los Angeles, Calif. 90024, (213) 478-0611.

Southern Offices: H.V. Brown, H.V. Brown Associates, 5825 Glenridge Dr. N.E., Building 2—Suite 116, Atlanta, Ga. 30328, (404) 252-9820.

# I know my taste.

No one has to tell me why I smoke. I could recognize my cigarette blindfolded. I smoke Winston. Winston is all taste—that means real taste and real pleasure. For me, Winston is for real.

Warning: The Surgeon General Has Determined That Cigarette Smoking Is Dangerous to Your Health.

20 mg. "tar", 1.3 mg. nicotine av. per cigarette. FTC Report SEPT. '75.



Sirs:

What do you get if you cross a Hapsburg with a Romanov with a Hohenzollern? *A hemophilic hydrocephalic monster whose estate house is open to the general public Tuesdays through Fridays at 2s6d a head!*

Charles Windsor  
Buckingham Flats  
Nothing Hole That Ever  
Must Pay Rent, What? U.K.

Sisters:

Listen, if my up-and-coming book of outrageous female humor is called *Titters*, should I call my book of Negro humor *Sniggers*?

Anne Beatts  
Deco, N.Y.

P.S. Please don't tell Mr. Michael

O'Beatts I wrote this, he'd cry and cry if he knew I gave you back one of your jokes.

Sirs:

Even though I'm a sheet metal contractor, I read your magazine avidly. The recession has, alas, hit my industry pretty hard, and I'm afraid I'll have to cancel my subscription. I've tried to do the right thing for my kids, God love 'em. They'll never run short of Alpo and Ritz Crackers while daddy's alive. Sorry about the cancellation.

Tappan Dye  
Toyle, Mich.

Sirs:

I'll bet you think you really piss me off with the various nasty things you say about me in your magazine, like that letter in March about me and Caroline Kennedy, or that "Jizz Wenner" column you run in the "News" section. Well, you don't. So there! Ha! Every knock's a boost, that's what I say. I'm tough. I'm thick-skinned. Insults roll off me like water off a duck's back. Besides, you guys are too dumb to figure out how to hurt my feelings. If you had any brains, you'd make fun of me for

being overweight. *That's* what I'm really touchy about. You'd call me "Pork Butt," "Blubber Puss," "Suet," "Beef Trust," "Lard Ass," "Pie Wagon," "Blimp Face," "Pudge," "Butterball," "Sow Belly," "Ham Fat," "Bulge Bottom," "Puff Gut," "Flab, the Wonder Editor," "Boat Hips," "Crisco Kid," or "Human Garbage Can," if you really wanted to get my goat. But you aren't that smart.

Yawn Wenner  
Rolling Stone Magazine  
for Young Adults  
Still over the Jap Restaurant  
on 56th Street, N.Y.

Hey, Christians:

Come out, come out, wherever you are! Ally, Ally, in-free!

A Pack of Savage Moslems  
with Bazookas on the Roof  
Beirut Hilton, Lebanon

Hey, Guys:

Look, fun's fun and everything and I can take a good ribbing as well as the next guy, sure. But, come on, there are some things that just aren't funny. I mean, *I do not eat other fellows' shit off of plates with a fork.* I don't ever do that. I've never ever

continued on page 12

## ANOTHER STRONG STATEMENT FROM AKAI!

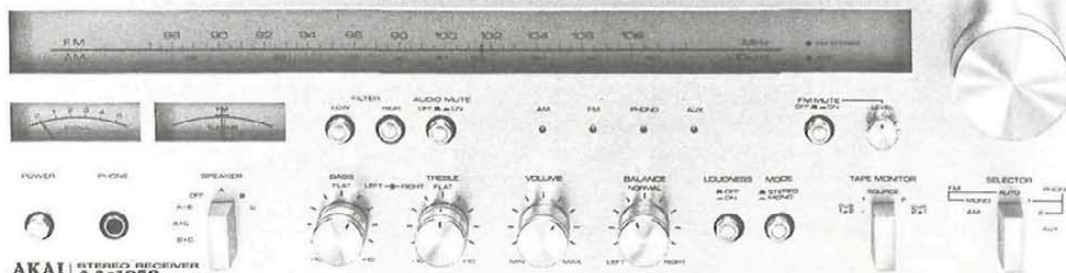

This is our AA-1050. Our top-of-the-line stereo receiver. It's part of Akai's new line of Stereo and Quad receivers, the Akai 1000 Series. We believe it's the finest line of receivers, for the money, in the business.

Like all our receivers, the AA-1050 was built with the same commitment to quality that made Akai tape equipment internationally famous. We honestly don't see how the AA-1050 can miss. We haven't

found another receiver that comes on, for the price, with better sound or better performance. Or better styling. If you think we look good in this ad, you ought to see us up close. Clean. Brushed aluminum. Beautiful.

The strength of Akai. It's in our AA-1050. It's in our 1000 Series. With power output from 14 to 80 watts per channel, there's an Akai receiver made for you. So you can make your own strong statement.

**AKAI**  
COMIN' ON STRONG!

Malcolm Hereford was an inventive and crusty old hedonist who made his fortune breeding bulls.

A stubborn man, he did things to his liking, regardless.

He liked "strong drink."

But not its taste.

Or its smell.

So, he did as only he would do.

He turned his considerable resources to creating drinks to please all the senses.

He succeeded with a blend of natural flavors and grain neutral spirits.

Each is spirited.

Each pleasant tasting.

Each pleasing to the eye.

And each smooth and light to the palate.

Once done, and with the final iconoclastic twist of wit,

he named them "COWS."

We heard of Malcolm's private "herd."

And found them to be a delicious and spirited new breed of drink.

So, with Malcolm's blessing, we've turned them loose.

Try them on-the-rocks or chilled. You'll discover one thing for sure:

**A Cow-on-the-rocks is not a bum steer.**



# INTRODUCING MALCOLM HEREFORD'S 30 PROOF COWS.

The Spirited New Breed of Drink.

# Is it live, or is it Memorex?

The amplified voice of Ella Fitzgerald can shatter a glass. And anything Ella can do, Memorex cassette tape with MRX<sub>2</sub> Oxide can do.

If you record your own music, Memorex can make all the difference in the world.

**MEMOREX** Recording Tape.  
Is it live, or is it Memorex?



©1976, Memorex Corporation, Santa Clara, California 95052

## Letters

continued from page 10

done that. I never will do that. Not even once. And I think it was really disgusting for you to tell everybody that I do it all the time. It was really low to say something like that. There's nothing humorous whatsoever in that kind of accusation. Why on earth would you...huh?...You didn't?...You're sure?...You're positive you never said that? Uh...gee, I could have sworn...you really didn't? Maybe it was *People* magazine. Anyway, I want to get one thing straight in everybody's mind: *I do not eat other fellows' shit off of plates with a fork.* O.K.?

Chevy Chase  
c/o NBC Ding Dong School  
Zero Rockefeller Center, N.Y.

Sirs:

How much do you guys pay for cool subscription ads, like the one that says how wacky you are and how sick your humor is? Whew, that was selling genius at work. I bet any money McConnachie wrote it. Anyway, like here's my idea: we get Brian McConnachie and he's in a ditch with this pig, see, putting a few shots up the porker's exhaust pipe, then we put a headline on it, you guys will have to do that, and the headline says: Buy This Magazine and You Can Fuck This Pig in a Ditch Just Like Brian McConnachie. Talk about crack-jar whack-ass funny, this one will put a few lunches into orbit! In the next few months we'll change it a bit so us readers don't get bored with too much subtlety. Buy This Magazine and You Can Hump This Jackrabbit in a Culvert, or Buy This Magazine and You Can Jam This Otter in a Swamp. If I get paid good, I don't mind working the ideas up a bit more and think of how much money you'll be able to save because McConnachie will pose for free. Also, how about some more articles on pee and ink? I work cheap.

Billy Two Jobs  
New New Orleans

Sirs:

Up the ass of the ruling class, right? Your place or mine?

Lina Wertmüller  
Baloney, Italy

Sirs:

Have you seen the latest "Pringles Newfangled Potato Chips" commercial? Just goes to show if niggers will

continued on page 14



**OLD TRICK:** Modoc lifts her huge foot for retired animal trainer Fabian Redwood — just like she used to do.

## Elephant Recognizes Circus Trainer She Last Saw Over 50 Years Ago

Do elephants forget? Never, says retired animal trainer Fabian Redwood, and he proved it during a recent reunion with a famous cir-

Mo" hadn't forgotten him. Redwood sat down on the grass in front of the 9,180-pound creature and gave her another order.

"Redwood went right up to her and commanded, 'Trunk

reunion  
vertically  
astonishing  
"There we  
jects in the

NATIONAL ENQUIRER ©1975

# Here's another juicy bit of news.



Many people (about 6) have inquired as to whether or not there was another way to down a shot of our classy Gold, aside from the salt and lime ritual.

There is. And since for some obscure reason you've read this far, we'll tell you the way.

Mix 3 oz. of tomato juice, 1-1/2 oz. of orange juice, juice from 1/2 a lime, 1 tsp. of grenadine, a little salt and a touch of tabasco.

In Mexico, this juicy concoction is called Sangrita. You can sip the chilled Sangrita and Gold alternately or you can mix them together.

That's something for you and your grocer to work out. We refuse to get involved.



**NATIONAL  
LAMPOON**

**A  
DIRTY  
BOOK**

A paperback book  
literally scraped from  
the pages of the  
*National Lampoon*.

●  
Not for the easily  
offended.

●  
Not for the occasion-  
ally offended.

●  
Available at book-  
stores whose proprie-  
tors are strong  
proponents of the  
First Amendment.

If for some strange reason  
you can't find it anywhere, send  
\$1.50 plus 50¢ for postage and handling to:

**National Lampoon**  
635 Madison Avenue  
New York, N.Y. 10022

**P.S. It's A Dirty Book!**

**This year,  
there will be  
thirteen issues  
of the  
National Lampoon.**

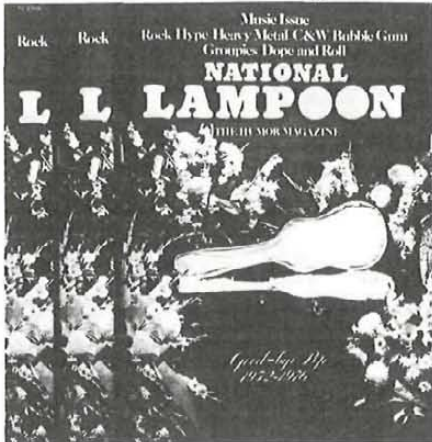

**One of them is a record album.**

**The National Lampoon Music Issue, "Good-Bye, Pop,"  
on Epic records and tapes, is now available at record stores.**

**Letters**

*continued from page 12*

eat paint chips, they'll eat *anything*.  
Ed Peckerwood  
Dumpruck, Ill.

Sirs:

Speaking of niggers, it sure is a  
good thing that your staff is filled with  
Pinkie-Winkies and dinky-dicked  
Left-Leaners or you'd probably be  
frying my ass but good for the way  
I'm handing Angola over to the  
nigger Communists, huh? I mean  
think about nigger Communism for a  
minute—not only will they just lay  
around and eat melons all day, but  
there'll only be one flavor of melon.  
I don't care. Anything to get rid of  
Pat Moynihan.

Hank the K  
State Dept. Tent-Head Desk  
Washington, D.C.

Sirs:

I assume you've noticed that we  
have borrowed a few of your column  
ideas. It's a delicate subject, isn't it?  
Lord Gnome  
*Private Eye*, England

Sirs:

With regard to your recent request  
that I write an article dealing with  
pee and ink, I find that after several  
weeks of research, the only concrete  
facts I could come up with are:  
Brendan Gill, long time staffer at the  
*New Yorker*, is accustomed to drinking  
pee out of inkwells. Please forward  
my kill fee immediately.

Johann Pachelbel  
Musicians Corner  
The Tombs

Sirs:

I should worry,  
I should care,  
I should marry a millionaire.  
Jackie O.  
Bloomingdale's Husbandwear Dept.  
New York, N.Y.

Sirs:

I'm writing as Chevy Chase's  
personal physician to request that  
you please cease holding Mr. Chase  
up to ridicule in your magazine.  
Chevy is a very sick man. He has a  
terrible case of tennis asshole. This  
may prove fatal.

Dr. Denton  
NBC Nurses' Office  
Zero Rockefeller Center  
New York, N.Y.



Quality speaker systems distribute the audio load between a combination of two or more speakers. Low frequency sounds are produced by the larger woofers, while high frequencies are generated by the dome or horn driver or an ele...

**WHICH SPEAKERS ARE BEST FOR YOU?** Individual listening taste, and even preferences, don't agree.

The sensible way to buy speaker systems is to listen to the ones you like. A-B test the two favorites by listening to music back and forth between the two systems. Differences (Keep the volume level the same) will fool you and the louder speaker system always note the power requirements of other components.

Most turntables are driven by the indirect method, whereby the platter is turned either by idler wheels or by a belt drive (better) connecting the motor to the platter. The most sophisticated units employ the direct drive method which eliminates the idler wheel system by coupling the driveshaft of the motor to the platter.

**WOW AND FLUTTER.** The most common cause of wow-and-flutter and signal-to-noise ratio is a variation in speed below 20 RPM.

Quality, the percentage of wow should be less than 0.2 percent. Changes above 30 cycles per second also cause wow. A turntable's flutter rating is less than 0.1 percent. The quieter the turntable, the better. It is usually related to the quietness of the motor. A signal-to-noise ratio of 45 dB is good, 55 dB is excellent.



# AN INTRODUCTION TO STEREO.

At Yamaha, we feel uniquely qualified to introduce you to the joys of true stereo high fidelity sound.

Since 1887, Yamaha has been making some of the finest musical instruments in the world. Pianos, organs, guitars, woodwinds, and brass.

With our musical instruments, we've defined the standard in the production of fine sound. And today, with our line of state-of-the-art stereo components, we're defining the standard of its reproduction.

However, at one time, owning a Yamaha stereo system tended to be a rather expensive proposition. Our "ultimate" system, for example, hailed by the critics for such innovations as Vertical-FET circuitry and beryllium dome speakers, carries a suggested retail price of over \$7,000.

But now, Yamaha introduces a selection of new stereo components that let your Yamaha audio dealer create a high quality system for a suggested retail price of around \$700.

What you're getting is the same performance and design concept of our most expensive system, but without the frills. Also, each component has been specially selected and matched to enhance the performance of the other components.

**The Receiver:** There's a lot more than power to our new CR-450 stereo receiver.

You'll enjoy brilliant tonality resulting from super low distortion—0.1% intermodulation and total harmonic distortion. (These figures are amazing, considering most other competitive receivers are typically .5% to 1.0%!) In addition, Yamaha offers a full complement of functional features on the CR-450. Twin meters for precise tuning. High and Low Filters to eliminate noise interference. And two headphone jacks, so you don't have to listen alone. Plus our own exclusive Variable Loudness Control, which gives you full tonal balance—even at low volume levels.

**The Turntable:** Yamaha's new high-performance YP-450 shares many of the features of our "ultimate" system turntable, the YP-800. A low mass tonearm, with adjustable height and anti-skating, allows the stylus to track flawlessly at the lightest pressure. And the cue control is viscous-damped in both directions to prevent record damage. A handsome walnut-grained base and a dust cover are standard.

**The Speakers:** By the careful refinement of proven acoustic and electronic engineering principles, Yamaha's NS-2 rivals the sound quality of many larger, more expensive speakers.

The NS-2's soft dome tweeter and high compliance, foam surrounded woofer (the same design principles featured in our superlative NS-690 speaker) offer excellent high frequency dispersion as well as clean, accurate bass reproduction.

Underneath the NS-2's removable grille cloth, quality construction is evident in the fully finished front cabinetry.

**The Headphones:** Yamaha's patented new Orthodynamic design HP-2 combines the smooth highs of the best electrostatic headphones with the full, rich bass of the best dynamic types.

In addition, the HP-2 features comfortable featherlight styling by famous Italian designer Mario Bellini.

**An Introduction to Stereo.** Chances are, when it comes to understanding terms like watts, dB's and signal-to-noise ratios, you're probably a little confused. So we've prepared a booklet that explains the basics of the world of sound. Appropriately enough, it's titled "An Introduction to Stereo."

To get your free copy, just send us the coupon. Then, once you know the basics, visit your local Yamaha audio dealer. His knowledgeable salesmen and extensive demonstration facilities can save you a great deal of time and money in helping you select a system. And his first-class service will keep you happy.

So talk to your Yamaha audio dealer. His experience and your ears make the perfect introduction to stereo.

So talk to your Yamaha audio dealer. His experience and your ears make the perfect introduction to stereo.

Yamaha International Corporation,  
Audio Division, P.O. Box 6600-C,  
Buena Park, Calif. 90620

Please send my free copy of  
"An Introduction to Stereo."

NAME \_\_\_\_\_

ADDRESS \_\_\_\_\_

CITY \_\_\_\_\_

STATE \_\_\_\_\_ ZIP \_\_\_\_\_



**YAMAHA**

## TIPS AND TALES

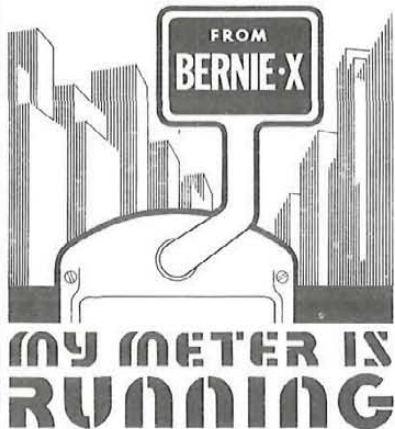

If you remember, the last time I spoke to you I was just leaving Beverly

Hills, California, to drive back to good old New York. All because Cher made me take her by cab from New York to the Coast on a crazy whim. Oh, she paid for the fucking thing. You can bet your sweet satchel on that. And she gave me a \$5,000 tip to give me a head start back. And that's not all she gave me. I told you that I took her cherry, didn't I? Oh, yeah. Oh, sure. Y'know why, doncha? She was still a virgin. I was the first. So naturally she went crazy over me. She wanted to set me up in L.A. as her personal manager. Wanted to give me a house, a car, a colored maid, any fucking thing I wanted, as long as I stayed with her. But I can't take these movie stars for too long. You never know what they're going to do from

one minute to the next. They all belong in the crazyhouse. Cher tried to commit suicide when I left, y'know. That must be their fucking hobby, those movie stars...attempting suicide. She took a whole listful of these pills, only they were the wrong kind and all she got was a bad case of constipation. Poor kid. She's still begging me to come back.

Anyway, there I was, all set to drive back to New York. I had a five grand tip and the open road in front of me. So what's the first thing I do? Make a side trip to Vegas, naturally. I figured I could parlay my five grand into a bigger wad. One of my weaknesses is gambling. But in my case it's not a weakness because I never lose. You don't believe me? Ask any fucking bookie. They don't take my bets anymore. I took over a dozen bookies to the cleaners in my time. Once in a blue moon I'll lose a few dollars, but nine out of ten I win. I'm deadly.

So I check into Caesar's Palace and make a beeline for the craps table. I'm starting to tremble, to feel hot all over. I got magic in my palms and money oozing out of my fingers. This is going to be the night. I can feel it in my bones. I get the call to shoot a few and run up a nice quick string. Boom, boom, boom—you can feel my luck running through the whole room. Word gets around. There's a hot hand at crap table number six. I work better with a crowd behind me, y'know. I got this acting streak in me. I like to show off in front of a big bunch of people. So everything is working that night. It's magic every step of the way. I can't lose. I'm taking the fucking house for a big wad—a hundred, a hundred fifty big ones. I'm up to maybe two hundred when this unmistakable voice behind me puts 500 grand on my next roll. A double six, no less. One of the toughest numbers in the book. And I score on the first roll. The fucking mob behind me goes crazy. I turn around to see who threw 500 Gs down and it was none other than the Chairman of the Board, Ol' Blue Eyes—Frank himself. While everyone is jumping up and down, he don't even crack a smile. He gives me a light tap across the jaw and says, "I like you a lot. You got good hands, kid. Take 50 Gs for yourself. And if you're not doing anything tonight, come over to my place about ten. We're having a little party." And one of those gorillas who guard him gives me his address.

# THE PEAVEY 800 STEREO MIXER

## Compare the advantages!

The Peavey 800 S is, without question, the best mixer buy on today's market. Compare its features with those of other mixers in its price range:

Eight channels with the very latest variable negative feedback circuitry.

Each channel features separate low & high equalization; pre & post capability for monitor, reverb, and effects send controls; attenuation; stereo pan; and slide level control.

Master section features slide level controls for left and right main & monitor; low, mid, and high equalization for left & right mains; master level, return, and pan controls for the effects and reverb busses; and two lighted VU meters with screwdriver adjustment.

Rear panel features eight low (600 ohm) inputs and eight high (50 K ohm) inputs; left and right main & monitor outputs; auxiliary input panel, and a stereo phone jack for taping out.

Suggested retail price: \$649.50 at your Peavey dealer.

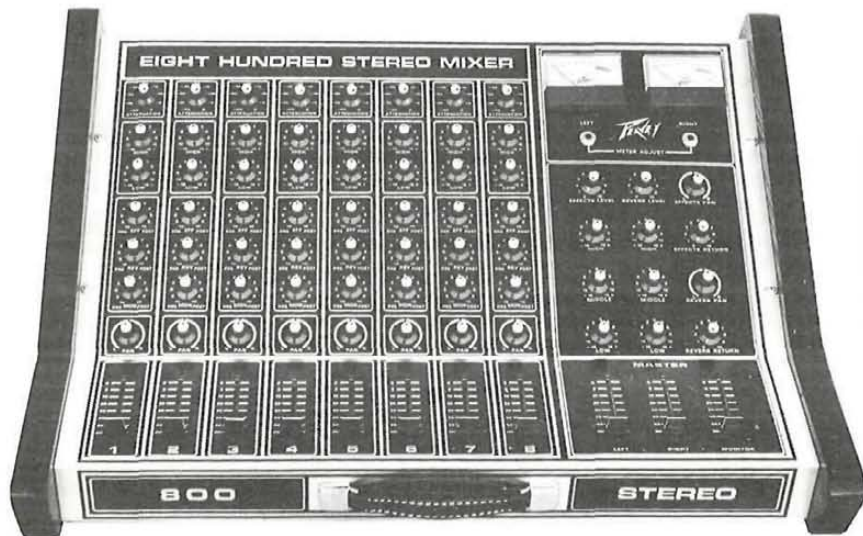

### PEAVEY ELECTRONICS CORP.

# More cigarette VS. your cigarette.

1. Is your cigarette as long and as lean as our cigarette for more pleasure, more style?
2. Does your cigarette draw as easy as our cigarette for more tobacco enjoyment?
3. Does your cigarette smoke slower than a 100 mm cigarette for more smoking time?
4. Does your cigarette come in a burnished brown wrap so it looks as good as it smokes?
5. Does your cigarette sit neat in your hand like it was made for it and fit your face like it found a home?
6. Does your cigarette give you all this yet cost no more than a 100 mm cigarette (which means more for your money)?

If the answer to all these questions is yes, your cigarette is probably More. Because there's only one cigarette that's so much more. More.

## The first 120mm cigarette.



Warning: The Surgeon General Has Determined That Cigarette Smoking Is Dangerous to Your Health.

© 1976-83 REYNOLDS TOBACCO CO.  
FILTER: 21 mg. "tar", 1.5 mg. nicotine, MENTHOL: 21 mg. "tar", 1.6 mg. nicotine, av. per cigarette, FTC Report SEPT. '75.

## My Meter Is Running

continued

So that night I go over to Frank's house for one of his wild parties. Jesus! I can't fucking believe it! My one idol...Frank Sinatra...inviting me to a party. Booze...broads...ring-a-ding-ding...God knows what'll be there. And I'll meet Sammy and Dean and Joey Bishop. All the best fucking people in the world. Now I've been around. I've fucked the best...big movie stars...society ladies...you name it. But I was really thrilled to be invited to a party like this.

Of course, the door is opened by a butler, who takes my hat and leads me to a Chink-type guy who takes me into a bar where an Irish bartender is making drinks. I'm not a big drinker, so I'm glad he's got my favorite, a Manischewitz Cream Sherry spritzer with a twist.

What a beautiful fucking house I'm in. Frank really knows how to live, believe me. I can't describe how it's decorated, but it looks like a house I once saw in a Tyrone Power movie that was set in Mexico. Not those shitty Mexican houses the peasants live in, but one of those palaces. There's a lot of this old secondhand furniture and rugs everywhere, but I figure it must be good stuff if Frank has it in the house. "Where's the party?" I ask the bartender. "Upstairs in the hobby room," he says.

Hobby room. I wonder what kind of crazy hobbies Frank is up to. Carving his initials on a broad's ass, probably. What could he be up to? I don't hear any noise up there, except for some funny kind of violin music. I go in the room and there they are—Frank, Dean, Sammy, Joey Bishop, Jilly, Frank's old friend, and a bunch of bodyguards and other people I don't know. No broads. A little booze, but nobody is really hitting the bottle. There's this dopey music on the Victrola—must be Mantovani or Mozart or something. And here's where I nearly fainted. Frank is sitting at this sewing machine making a dress. He's working on this fucking dress pattern, something with little flowers. And that's not all. Sammy is also making a dress on his sewing machine. Bishop is making one of those quilts with the patches and a lot of the other guys are doing these funny hobbies like making bridges out of toothpicks, weaving rugs and whatnot. Dean was sleeping, of course. For a second I thought I was in the wrong

house. I must be in a nursing home or something. But it was Frank and all the boys, all right. Frank waved at me and told me to have a drink. I took a close look at him and got the second shock of the night. The man was turning into a woman, an old lady! No wonder he was making a dress. His face was really just like a woman's. And his body seemed to be growing little tits. Not like a plump guy, but real woman's tits. The other guys looked normal. It was just Frank. But when Frank does something, the other guys have to follow. Frank can't do anything alone. He needs a lot of people around him. So everybody was doing some kind of woman's type hobby.

God almighty...what happened to the poor guy? I had a couple of Scotches and asked big Jilly what the story was. Jilly told me that Frank was undergoing one of those sex changes. When he's out with a big crowd, like at Caesar's Palace, he tries to act like the old Frank. But when he's at home and can relax, he seems to become more and more like a woman. He seems to like it better. Jilly looked very upset, very worried. He said there was going to be a big meeting later that night to discuss Frank's problem. Frank's agents, personal managers, lawyers, accountants, advisers, associates, and friends were coming over to figure out what he should do. He was getting tired of living this double life. Jilly said I was welcome to stay as long as I liked. The party was no fucking bargain, but it was better than a finger down my throat, so I figured I might as well stay.

So later that night they had this big meeting. All the big shots were there. All of Frank's best friends. You name them—they were there. Hope and Crosby, Joe DiMaggio, Johnny Carson, Ed MacMahon, F. Lee Bailey, all those guys from the Mafia, and you guessed it, Nixon and Agnew. Agnew looked terrific. A beautiful tan, a pink golf shirt with red pants, and red and white golf shoes. Nixon looked like an old lady. Wait a minute. Not him too. Sure as shit, it was true. But no one seemed to notice him much.

Frank starts the meeting with a song, "My Way," proving he can still belt 'em out, even though his voice isn't the complete instrument it used to be. There's a little band playing behind him, by the way—a live band.

When the clan and other close friends meet, they don't applaud Frank after he sings a song, they walk over to him and give him a very gentle tap on his jaw with their fist. Like Jimmy Cagney used to do in his movies when he liked you.

Then Frank asks people for their opinions about his sex change. One thing about the Chairman, he wants everybody to speak his mind. No bullshit around him. Before anyone has a chance to say anything, Sammy sticks his head between Frank's legs and starts crying. He bawls and says that if Frank gets a sex change, he'll get one too. He's got to be exactly like Frank or he'll die. Frank pats him on the head but says no dice—the world couldn't take a girl as ugly as you. "You're beyond the skills of plastic surgery," he says. Of course, Frank is saying this good-naturedly so Sammy's feelings wouldn't get hurt. Sammy just laps it all up like a black puppy.

Joey Bishop gets the floor and comes straight out with the opinion that Frank should go all the way and get a complete sex change. He feels that it would do Frank a world of good. Frank is not getting any younger, says Joey. He's probably had just about every sexual experience a man can have, every kick, every pleasure. He's won the highest accolades a man can win in show business. He never has to worry about money again. What other worlds can he conquer as a man? He's not going into politics, right? And at this point he looks over to Nixon and Agnew and gets a weak laugh out of them. He's not going to study medicine or law. His

continued on page 31



Say—here's a way to fool all of the people  
all of the time...

# Can a speaker be all things to all people?

**Say music enthusiasts** — “I have to relisten to all my Pink Floyd and Frank Zappa albums because I realize now I never really heard them before. Freaks me right out!” *LARRY ROGAK, N.Y.*

**About accuracy** — “Elton John sounds like Elton John and not Wayne Newton with a sinus condition. All kinds of music sound great, from Percy Faith to Led Zepplin.” *GRANT HOWES, MICHIGAN*

**You can play it loud** — “I once read it was not possible to have a rock concert in your home, but with the B-I-C Venturi it is possible.”

*RICHARD KNES, ILLINOIS*

**Or play it low** — “I feel I must write...to thank someone that realizes there are a few of us who don't like our stereo and quad up blasting our eardrums. These Formula 2 are great at any volume.” *MRS. GAIL MCAULOF, CALIFORNIA*

**From professional users** — “I am a disc jockey and work with some of the finest sound equipment available... I purchased a set of your Formula 4's after a year of shopping around... In my opinion none sounded better at any price.” *DAVID FOOR, FLORIDA*

**And audio engineers** — “I am an audio engineer at (AM, FM, TV broadcast station)... An excellent speaker and a great design concept.”

*PHIL JONES, SOUTH CAROLINA*

**Even people who sell audio** — “You've really got the product... my recommendation 9 times out of 10 is B-I-C Venturi.” *DAVID WILLIAMS, TEXAS (DEALER)*

**And those who've lived with it** — “Nearly a year ago I purchased a pair of Formula 6... the performance has substantiated my original beliefs.”

*JERRY GRETZINGER, MICHIGAN*

**So join this fellow who says** — “I could not be more pleased with the performance of your product, nor with myself for having the good sense to have chosen them!” *RONALD BERTHEL, N.Y.*

**Because you can believe** — “I was somewhat skeptical about the claims in your advertisements... I purchased a pair of Formula 6... Your speakers surpass all the claims made... They are fantastic!” *RANDOLPH L. KRUMM, N.J.*

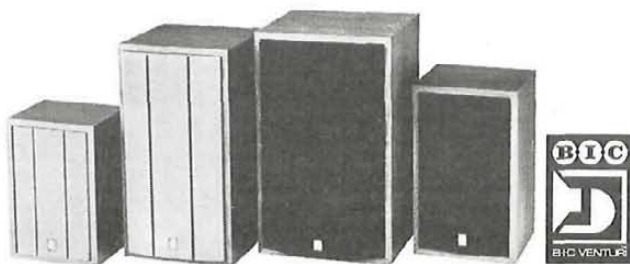

WRITE FOR OUR 20 PAGE CONSUMER GUIDE TO LOUDSPEAKER PERFORMANCE: B-I-C VENTURI, WESTBURY, N.Y. 11590

BRITISH INDUSTRIES CO., A DIVISION OF AVNET INC. © 1976

**B-I-C VENTURI**™

Copyright © 2007 National Lampoon Inc.

# For a winning deck, pick a Sansui.

SC 636

With the development of the Sansui cassette decks, the cassette can truly be called a high fidelity medium. Only with the technical accuracy and near perfection of these Sansui models can the musical recording and reproduction do full justice to the capabilities of the cassette being used.

The new Sansui vertical front-load series has achieved extremely low wow and flutter by isolating the capstan drive from the reel drive. This is accomplished by a slip-free drive belt coupled to a mirror finish, extra large flywheel. Our new decks incorporate the newest Dolby® IC chip technology to give you a full 10 dB improvement in signal-to-noise ratio. All mechanical controls are inter-locked so you can go directly from any mode to any other without going through stop, to prevent damaging valuable tape.

The SC-3000 and SC-3003, top-of-the-line models with 0.09% (WRMS) wow and flutter are stacked with attractive features: front-access tape compartment positioned right-side up, fully automatic stop-shut/off, a reliable and easy-to-read 3-digit tape index counter with a very useful Memory Rewind Section, highly accurate VU meters, peak level indicator, extremely hard Permalloy record/playback head for long life and outstanding performance.

All four models in this Sansui series, from under \$290.00\*\* to under \$370.00,\*\* share many of the same outstanding features for true high fidelity performance at attractive prices.

The Sansui SC-636<sup>1</sup> at under \$280.00,\*\* a leading all-around deck, delivers fine quality sound without costly frills. As with the higher priced models, the SC-636 offers fully automatic shut/off, illuminated VU meters, built-in Dolby® Type B Noise Reduction System, low wow and flutter and an excellent signal-to-noise ratio.

Sansui has stacked its decks. Stop in at your nearest franchised Sansui dealer today and buy one of these outstanding new Sansui series to stack yours.



\* Dolby is a trademark of Dolby Laboratories Inc.  
\*\* The value shown is for informational purposes only.  
The actual resale price will be set by the individual Sansui dealer at his option.  
<sup>1</sup> Simulated walnut grain



## SANSUI ELECTRONICS CORP.

Woodside, New York 11377 • Gardena, California 90247  
SANSUI ELECTRIC CO., LTD., Tokyo, Japan • SANSUI AUDIO EUROPE S.A., Antwerp, Belgium  
In Canada: Electronic Distributors

# Wholly Sane Wife Axes Self, Child—Spares Hubby

Details Inside

OUTLOOK:  
Bleak  
AIR QUALITY:  
Acceptable



Our Advertisers  
Sure Are Swell  
So Let's Go Out  
and Buy Like Hell

IND  
34490

## The National

\* \* \*

SERVING THE NATIONAL LAMPOON SINCE 1975

Volume 1, No. LXXII

April

Yellow Streak Edition

100 cents

# EX-SINGER HELD IN N.J. SLAYING



Paterson, N.J.—A triple murder that occurred over nine years ago in a Paterson, New Jersey, bar for which Reuben “Hurricane” Carter was sent to jail is the subject of a reopened investigation today.

Bob “Robert Zimmerman” Dylan, who recently released a ballad about the crime entitled “Hurricane,” was unable to explain where he got information about the crime that even police and Mr. Carter were unaware of until hearing the song. When asked for comment on Dylan’s guilt, Mr. Carter replied, “It’s about time the man come around. I been telling you all for nine long years that it wasn’t me, but you wouldn’t

listen to a colored man. Now that the Jewboy has returned to the scene of his crime, I hope you are satisfied.”

In 1966, when the crime occurred, Dylan was still a struggling folksinger and was said to have been in desperate need of cash. He and a friend known only as “Bruce from Asbury Park” were supposedly observed cruising Paterson in Dylan’s beat up white sedan at odd hours almost every night. When Patty Middletime, the prime witness for the prosecution, was asked about the discrepancy in her testimony and how she could have possibly thought she saw two black men, she replied, “Well, it was very dark that night, and I guess that when I saw the big lips and the curly hair, I just assumed that they were Negroes.”

## Moe Udall Sues National Lampoon

Boardroom, 635 Madison—Moe Udall, dark-haired Democratic candidate for the presidential nomination and former member of The Three Stooges comedy team filed suit against the *National Lampoon*.

Udall alleges that the profitable humor magazine damaged his campaign by failing to hold him up to ridicule. In his suit, filed Thursday in the state of drunkenness, the Dem alleges that had his partners, Larry and Curly, been alive, his candidacy would not have been taken so seriously by the humor magazine.

In a brief statement to the press, NatLamp-Co chairman Matty Simmons said, "There's nothing funny about the way he sues. I told the boys to go easy on him, the slightest thing drives him absolutely wild . . . he sued his partners for breach of contract when they died."

## On the Shelf

*The Russian Swordfight*  
by J. Cutchacoff

This is a hard book to dig because there's a lot of big Russian type words in it. But sometimes it's funny as a bitch. I like the part where this Russian empress goes down on a horse.

# Fashion Whirl

## Oh, What A Lovely War

## of Liberation



Right on target in unisexy two-piecer. Blousy Castro Convertible top can be worn in or out, while hug-me-oooh-so-tight cinch belt adds a classic touch of working class. Matching gunmetal blue wrist ornaments from Skoda Boutique and très très chic.



Photo by Alan Hutchinson

Every day is May Day in now-you-see-me, now-you-don't jungle print top and campaign *chapeau* and just perfect for a frontal assault on Mr. Right. Budda budda accessory wand guaranteed to start your own insurrection.

Bullets are flying and passions are up up in hotter-than-sin Angola, and militant misses in the sexy subsahara are *guerrier* than ever in camouflage couture from Havana's very own Riki de Rebelión. "Third World doesn't have to mean third rate," Pouts Riki.

who was really turned off by those couscous sack burnouses that were all the rage in *Algerie*. Fashion-wise guerilla gals from Gungo to Huambo are suiting up *Internationale*-style with Riki's daring new "party" line, the ultimate in trooping toggery.



Serf's up for these happy *paysans*. With their fronts liberated to show off a yummy set of Mother Nature's very own bazookas, they're right in step with the times with peasant blouses, peasant wraparound skirts, and naughty peasant odds 'n' ends scrap hats.



Riki



# “The best songbook” published since the collected works of Sammy Kaye.

Carmen Lombardo  
*Alto Crocker Magazine*

The publishers, editors, producers,  
directors, writers, lyricists, music  
writers, actors, actresses, lighting  
men, sound directors, and  
wardrobe mistresses of  
just about everything  
the National  
Lampoon has  
put to music  
present:

Forty-seven songs with lyrics, music, and those little  
things with the swirls at the beginning of each song.  
Humorous full color illustrations throughout.

The full script, including words and  
music, of the National Lampoon Radio Hour  
musical comedy "Moby" —the show  
that made television an institution.

And the words and music from "Lem-  
mings," "The National Lampoon  
Show," the National Lampoon  
Radio Hour, and the best  
National Lampoon record  
albums, including the  
newest, "Good-bye,  
Pop."

100 pages in all  
...\$5.95 per  
copy.

## NATIONAL LAMP- POON Songbook

FEATURING MUSIC FROM THE  
NATIONAL LAMP-  
POON RADIO HOUR, THE NATIONAL LAMP-  
POON RADIO DINNER  
THE COMPLETE SCRIPTS OF  
"MOBY" AND "LEM-  
MINGS" AND  
ARRANGED FOR VOICE, PIANO & GUITAR

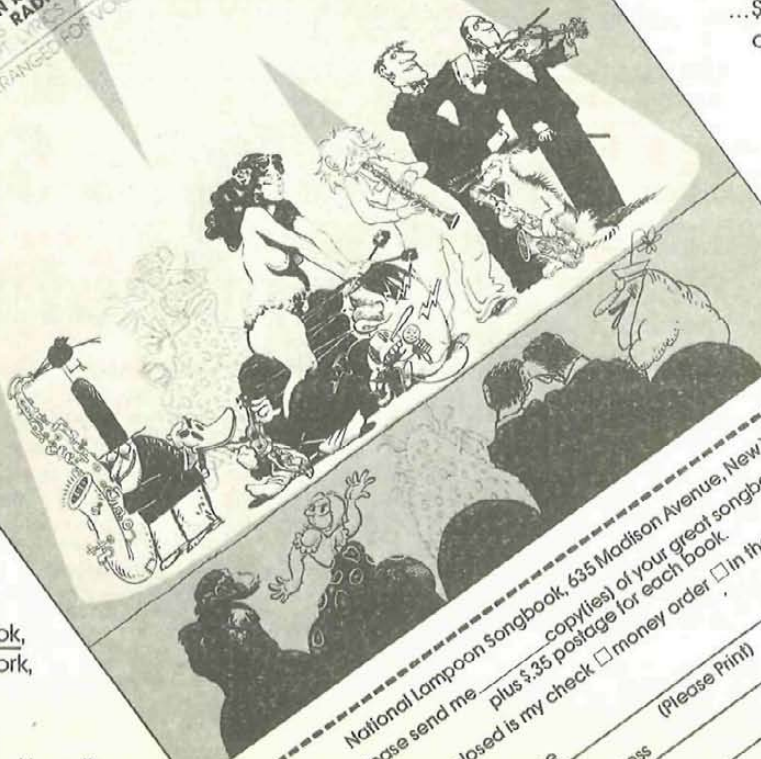

On sale  
at music stores  
or by sending your  
check or money order  
with the order blank to:  
National Lampoon Songbook,  
635 Madison Avenue, New York,  
New York 10022

Add 35¢ for each Songbook  
ordered to cover postage and handling.

National Lampoon Songbook, 635 Madison Avenue, New York, N.Y. 10022  
Please send me \_\_\_\_\_ copy(ies) of your great songbook at \$5.95 each  
Enclosed is my check  money order  in the amount of \$ \_\_\_\_\_

Name \_\_\_\_\_  
Address \_\_\_\_\_  
City \_\_\_\_\_ (Please Print)  
State \_\_\_\_\_  
Zip \_\_\_\_\_

# THE BEAT GOES ON

By JIZ WENNER

Topical rocker Bruce Springsteen, the one critic were calling "the old Bob Dylan" a few months ago, appears to be making a comeback. I for one am excited, for this is the first time a rock star has made so sudden a comeback after so recent a slip into obscurity.

Why did Springsteen slip into obscurity in the first place? This question has as many answers as there are vice presidents in charge of artist relations at Columbia records. "It was that leather jacket of his," says an anonymous Columbia veep. "It made him look like a Greenwich Village piss freak." Others place the blame elsewhere, often upon each other and strictly off the record.

Regardless of the reasons for the poet/composer's slip into obscurity, the rest seems to have done him good. He looks healthier and more intelligent than ever. Speaking about his recent comeback, Springsteen says, "I am glad to be back. It was hell there for a while. At first, people just stopped recognizing me, then they started mistaking me for Patti Smith. I hit rock bottom. The pits. What can you do, though, when you're that low a human being? All you can do is try... try and make a comeback. I was lucky, I got the breaks and what can I say... I owe everything to the people who made me what I am, from the sniveling, pudgy rock magazine publisher in San Francisco to the kid with the dollar in his pocket and the brains in his feet."

Many people are pleased to see Springsteen back in the middle and hard at work cutting a new album to be entitled "Born to Re-run," which will be based largely on his two- or three-month ordeal as a nobody. Stars like Bruce were not born to be tramps.

As if to put the final seal on Springsteen's comeback, two construction workers outside the Stage Delicatessen in New York offered to push his face into the wet cement.

Next month: Backstage at New York's fabled Bells of Hell bar with Turner and Kirwin, The Spitting Irish, and the Martha Graham Moving and Storage Dance Ensemble.

## Say Reagan a Suppurating Pustule

Informed sources revealed today that Republican hopeful Ronald Reagan is a

suppurating pustule whose pretty wife, Nancy, sleeps with unshaven merchant seamen for nickles.

## French Red Chief: Stalin Not Nice Person

PARIS—In a dramatic move today, French Communist Party Leader George Marachais formally declared his party's independence from Moscow after more than fifty years of kowtowing to the Kremlin.

Brandishing a copy of Alexandr Solzhenitsyn's eye-opening exposé *The Gulag Archipelago*, Marachais

leveled a torrent of savage accusations at Soviet bigwigs. Undaunted by shouts of "treason" and "impossible" from his listeners, Marachais claimed that former Russian party boss Josef Stalin had obtained false confessions during the infamous Show Trials of the Thirties, had been responsible for the deaths of millions of peasants through his policy of Forced Collectivization, and had even inked a non-aggression pact with unpopular German

Chancellor Adolf Hitler in 1939. Marachais further accused Stalin of terrorizing the Soviet people through the use of an "illegal" secret police force, of muzzling the Soviet press, and of "giving Communism a bad name."

Profoundly shocked, the French Party Congress decided to approve Marachais's move in an overwhelming vote. To make the split even more concrete, the Red leader then presented a

(Continued on page 6, col. 3)



## What's Shaking in Guatemala?

GUATEMALA CITY—Final casualty figures are still being tabulated, but the number of people killed in the recent earthquake in Guatemala is expected to reach 25,000, making it easily the worst natural disaster in South American

history. It is also believed to be the first time an earthquake has acted selectively, casualties being confined to members of the Communist party, urban poor and opponents of the regime in power.

TAKE IT FROM THE COLONEL

Colonel Marcis Registrada said that the army had done everything in its power to

locate survivors. "My men, they are exhausted. Everywhere have they searched, and finding not one wounded person. It seems this terrible act of God has killed them all dead. Such a shame."

Many of those who survived the quake were badly shaken. "It could," said one, "have been us instead of them."

# Flashlight on Bicentennial Vacations



by Brittanica Dimwidly

It's Bicentennial time again. A perfect time for you and your family to plan a vacation at one of America's historical landmarks. Bicentennial Landmarks are a wonderful way to combine history, recreation, sight-seeing and family fun into one unforgettable vacation. This year I've come up with some truly enjoyable places that are off the beaten track and well within your family budget.

The Aeolia Civil War Museum, Aeolia, Mississippi

This unique museum is devoted to the depiction of the Battle of Aeolia in the Civil War, the only battle involving a Chinese regiment that fought on the Southern side. In 1864 a small group of Chinese was ordered to defend this town against General Grant's army on its way to Vicksburg and they were easily defeated. Today there is still a small colony of Chinese who run the museum and speak in a charming southern accent. Every hour there is a colorful re-creation of this three-minute battle, a delight for young and old. And there is a lovely souvenir shop and restaurant right in the museum.

Lake Zachery, Lake Zachery, Vermont

Here is a vacation that combines a bicentennial landmark with one of our great natural wonders, a lake that is completely frozen all year round. Lake Zachery was the scene of the first naval battle of the Revolutionary War between the Zachery Irregulars and the British schooner *Worcestershire*. The battle ended in a tie. The British boat got stuck in the middle of the lake and was eventually destroyed in a storm. Lake Zachery also features the fabulous Ice-A-Poppin show and a fine restaurant and souvenir shop.

The Spartanburg Bee Caves  
Spartanburg, South Carolina

Visit these historic caves where a band of Union soldiers hid for two months before they emerged and were killed at the Battle of Spartanburg. The soldiers lived entirely on the honey produced by the incredible Spartanburg bees who live in these caves. The bees still produce their fabulous honey and you can see the process in full-color pictures and dioramas right in the caves. The honey is also available at the cave's handsome souvenir shop and restaurant.

# get off!

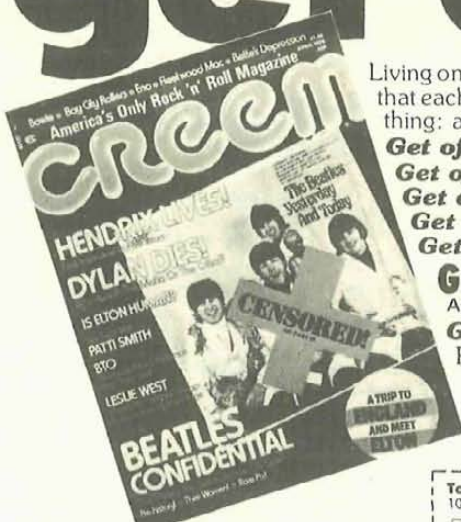

Living on this strife-torn globe, you know that each and every one of us needs one thing: a way to **Get off!**

**Get off** on the Lampoon

**Get off** your ass & strut yer stuff

**Get off** at Broadway & 42nd Street

**Get off** on parole

**Get off** on Rock And Roll!

**Get off on CREEM.**

America's Only Rock 'n' Roll Magazine

**Get off** this month on CREEM's Rock Revolution Bicentennial Contest! (Win a trip to **England** to meet **Elton John**.) Look for entry form and contest rules in this month's CREEM.

## WIN THE ROCK REVOLUTION!

Enter CREEM's Rock Revolution Bicentennial Contest.

Win a trip to **England** to meet **Elton John**.

Win Harley-Davidson™ motorcycles, year's supplies of 3M Scotch® Master™ cassettes, and Polaroid® Zip cameras. **Now in this month's CREEM.**

**Contest Ends July 4, 1976**

To Subscribe: Send to CREEM, Dept. #810  
10 Pelham Parkway, Pelham Manor, NY 10803

12 Issues - \$8.50       Check or M.O. Enclosed  
 24 Issues - \$14.00       Bill me.

name \_\_\_\_\_

address \_\_\_\_\_

city \_\_\_\_\_ state \_\_\_\_\_ zip \_\_\_\_\_

# THE SOUND VAULT



Every UD cassette gives you stainless steel guidepins to keep your recordings secure.

Tough steel pins form part of the internal security system inside every UD cassette. They make sure your UD tape runs smooth and winds even. (Ordinary cassettes have plastic posts that can wear out and cause wow and flutter.)

These steel pins are another reason your Ultra Dynamic cassette captures the very best sounds (both high and low) your equipment can produce.

Use Maxell Ultra Dynamic cassettes and you'll always play it safe.

Maxell Corporation of America, Moonachie, New Jersey 07074. Also available in Canada.

**maxell.**

For professional recordings at home.



# Sports Column



by Red Ruffansore

Used to be that Spring Training was a time when young players worked their butts off for a place on the roster, while the old vets caroused and raised holy hell down Florida way. Some of the real Greats of the Game were pranksters *par excellence*, and it's a cryin' shame that their like has disappeared in the era of blow-dry razor cuts and milquetoast reporters who don't know the difference between Jack Daniels and Rudolf Nureyev.

Ol' Red remembers the spring of '54, when Billy Martin cooked up a hot welcome for Elston Howard, the first Brown Bronx Bomber. One afternoon, Ellie was catching forty winks down in the hotel lobby when the Yankee Pepper Pot gave him a whale of a "hot foot"—one that started just below the belt. Ellie's balls went up like a pile of dry leaves and he must have made it from the lobby to the men's room in one second flat. Ever since, Ellie's been walking around with just one charred ball, but it was such a crazy prank that even he cracks a smile when Billy reminds him of it at Old Timers' Day with the perennial, "How they hangin'?"

Perhaps the best prank ever played was one that Ol' Red himself had to grin and bear. It was the day after Gehrig had got the Bad News, and, to tell the truth, the Fifth Estate needed a little cheering up. Ol' Red was Young Red then, down on his first trip to Florida for the old *Schenectady Sun-Ledger*. I was just moping around the hotel, feeling sorry for the Iron Man, when Granny Rice

and Ring came running in with a "hot tip" on a nag out at Hiialeah. They told me they'd file my story for me while I was out at the track making a killing. Well, just between you, Red and the lamppost, that horse shot out of the starting gate and fell to her knees! To top it off, the story Ring and Granny filed for me had John McGraw dropping dead right on the practice field from a dose of the clap! Ol' John took it in stride, but Red's editor fired off the ol' pink slip toot sweet. I didn't work for three years, but I never let on that I was even the least bit sore at Granny and Ring. Red sez, if you can't take a joke, you're in the wrong line of work, and that's a lesson for some of the candyasses who pass for sportswriters these days. Ring, if you're listening down in Hell, tell Granny that you two guys were one of a kind.

Speaking of pranks, remember those cries of, "Hector, you stink"? Well here's how it all started. Late one night, during spring training, Hector "Dumbo" Lopez snuck into his own locker and deposited a steaming turd in his own trousers. You should of seen the look on Hector's kisser when he pulled on his pants next day and felt that road apple sink in.

**The Old-Ones-Are-Still-the-Best-Ones Department . . .** When Jackie Robinson showed up for his first spring training in Vero Beach, Pee Wee Reese and Carl Furillo were on hand to show the young buck the ropes. "Look, Jackie," said Pee Wee, "all rookies have to take a turn being third base during sliding practice." It must have been sheer hell for Jackie, as one Bum after another came screaming into third, spikes flashing, but no one heard one word of complaint from the Brainy Blackamoor.

**Red Hots:** It's a tradition for the host country to propose one special Olympic event. Crazy Canucks are knocking their heads together choosing between the Hundred Mile Hitchhike, Cross-Country Leaf Identification, and Wading. . . No News Is Good News Department: No news is, crybaby Bill Walton broke his ankle. Good news ditto. . . Red's Rumor Mill has Cassius Clay (you heard me right) defending title against heavy-weight pop star Barry White for fifteen-million-dollar purse Labor Day weekend in Peking's Forbidden City. . .

(Continued from  
page 4, col. 4)

draft resolution to the Congress, declaring unequivocal support for NATO. "It is time for Communism to find a place within NATO," said Marachais, "only thus can it remain strong. A strong NATO is our best possible defense against the outbreak of a second world war."

In a related development Socialist Chief Francois Mitterand announced his party's break with the Second International. "A lot of Fabian playwrights use dirty words that are insulting to French womanhood," Mitterand observed.

The long-term effect of the ideological antics on the French left is still unclear but informed observers feel that a Communist-Socialist-Gaullist alliance may be in the offing. Asked to account for French Communism's "opening to the right," Marachais explained, "According to Lenin, it is the role of the vanguard party to articulate the felt aspirations of the broad masses. And, let's face it, a lot of our masses are, objectively, very right wing."

## Vacation

—A photo study in light and shadow by Susan Ford.

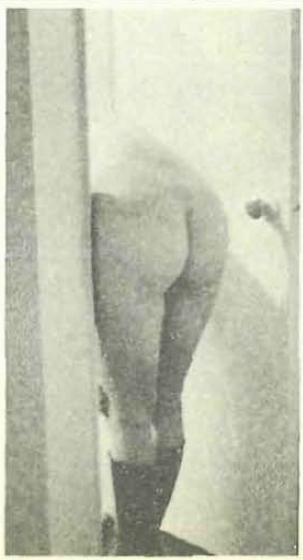
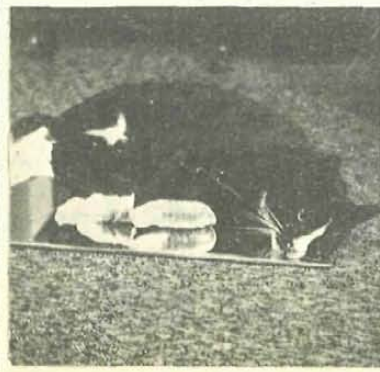

## Hump The Hump

WASHINGTON, AC/DC—Aides today announced that Bona Fide supporters of Senator Hubert Humphrey would be offered an opportunity to "Hump the Hump." Contributors to the Hump's campaign coffers and

convention delegates who support his bid for nomination will be offered an opportunity to sodomize the senator anytime prior to his taking the oath of office.

Several printing companies have refused to print bumper stickers outlining the offer; presumably, they are controlled by Republicans.

## Canadian Corner



**Subject:** CIA activities in Canada

Although customarily the National Lampoon does not concern itself with the overseas operations of the Central Intelligence Agency (if the children of wealthy easterners wish to spend their time giving Taiwan manicures to foreign nationals, extracting more fingernails than useful information, that is the price of their birthright), but in this case, the facts are far too serious for us to bear the responsibility of suppressing them.

Shortly before Christmas, the socialist government of Canada's westernmost province was overthrown by a free enterprise alliance. Vague, unsubstantiated reports of agency involvement began to filter in. Communication with the area was difficult and apparently unreliable; one early report had it that workers were duped by astute politicians who promised them, at the instigation of CIA strategists, that they would be given a raise in return for taking a pay cut. In order to ascertain the truth, hack writer Mike Croll, whose truth sense has been compared to the homing instinct of a drunken Irishman, was dispatched to the area. This is his report.

\* \* \*

Managed to avoid border patrol by distracting official in charge with hand puppet, Lysander. Made way by cab (American made but out of date: check of identification book silhouette makes it probable Chevy Bel Air '66 or '67) to the Marble Arch Hotel. Registered under name Matty Simmons, publisher, New York. No point in taking chances. If necessary to cough up poisoned lobster in a class joint or worm information out of street chicks with truth powder in the back of a rented Bricklin, don't want word of activities splashed in black across the local papers' night court report.

Used publishing cover to make contact with local lefty publisher. Code name: Big O. Picked up a quart of truth juice at the local liquor

*continued on page 33*

# Budget cure for the common hearache

Enjoy huge discounts, and end the agonizing pains of hearache! Our new stereo catalog will soothe your ears with music systems and single components from every major brand! The Warehouse Sound Co. cure includes fast delivery and shamefully low mail-order prices!

Comes in two pleasant forms: Merely drop us the coupon below and we'll send you our 96-page catalog, FREE! Or, include \$1 for postage, and we'll rush both our catalog and the 1976 Music Machine Almanac: it's a full-color 130-page guide to hi-fi equipment complete with photos and specs on 30 different brands.

For even faster relief . . . get amazing price quotes right over the phone! Call 805/544-9700 or write: P.O. Box S, San Luis Obispo, CA, 93405.

## WAREHOUSE SOUND CO.

## EAR-AID

I want fast relief, so here's my \$1 for both your 96-page color catalog and the Music Machine Almanac VIA FIRST CLASS MAIL.

Just send me the free catalog alone via third class mail.

name \_\_\_\_\_

address \_\_\_\_\_  
\_\_\_\_\_

city \_\_\_\_\_

state \_\_\_\_\_

zip \_\_\_\_\_

WAREHOUSE SOUND CO., Box S, San Luis Obispo, CA 93405 805/544-9700

J 9

# Many receivers may give you all this. But they cost a lot more.

At \$229.95\* the SA-5150 gives you more power and less total harmonic distortion than five of the other best known brands do at a comparable price (16 watts per channel, minimum RMS, into 8Ω from 40Hz to 20kHz with no more than 0.8% THD).

To hear all the lows of the bass guitar and all the highs in crashing cymbals without distortion you need a reservoir of power for instantaneous peaks. So we put two 4700μf electrolytic capacitors in the SA-5150's power supply.

For those who like their bass deep and natural (and who doesn't) the SA-5150's amplifier output is directly coupled to the speaker terminals. This means more power and clearer reproduction in the low frequency range.

To pull in weak FM stations with a minimum of noise, the SA-5150 has the kind of specs you need. Like 1.9μv sensitivity (IHF) and 70 dB selectivity. You'll also get superb separation and inaudible distortion (0.4% in stereo). Because the SA-5150 has a Phase Lock Loop IC and flat group delay ceramic filters.

Technics SA-5150. If you want all this in a receiver, it's the only receiver you want.

Technics turntables, tape decks, speakers and receivers. The concept is simple. The execution is precise. The performance is outstanding. The name is Technics.

\*Suggested retail price.

FOR YOUR TECHNICS DEALER, CALL FREE 800 447-4700. IN ILLINOIS, 800 322-4400.

# Technics

by Panasonic

Stereo Receiver - SA-5150



- Michael Fry and Kenneth Harris work in a Chicago gas station. Three gunmen entered the gas station early one morning, tied them with wire, and helped themselves to \$5,000 from the station safe and \$390 worth of cigarettes. The robbers fled, leaving Fry and Harris bound and gagged on the floor.

During the time they were tied up, the attendants said the station had a steady stream of customers. They looked in, saw the pair helpless on the floor, and then proceeded to take cigarettes and fill their tanks with gasoline.

After two hours of this free-for-all, one customer phoned police, although he did not leave his name because he was in the process of filling up his gas tank.

Authorities estimate that 100 drivers took part in the freebies. *New York Daily News* (J. Downey)

- Former child star Shirley Temple Black was never seriously considered as a successor for Daniel Moynihan, according to sources close to the president. Although he is pleased with her work in Ghana, Ford said he did not regard her as the kind of hard-hitting advocate of U.S. policies who could easily step into Moynihan's shoes. When asked to elaborate, the president said that whoever got the post would "follow the same policy of challenging the Third and Fourth World powers, calling a spade a spade." *New York Daily News* (T. Hendra)

- Ordered to produce a urine sample for a routine drug test, Sgt. Bradford Tobias said he could not do it with someone watching.

Tobias called it a "mental block."

The Air Force called for a court-martial. At the trial, two officers from a base hospital testified that such an inhibition was possible. Nevertheless, Tobias was found guilty. He was sentenced to thirty days at hard labor, was ordered to forfeit \$300 in pay, and was reduced one grade to airman first class. *Los Angeles Times* (D. Dunn)

- Gaetano Regoli and Aristide Goffi were driving toward one another in thick fog on a narrow road in rural Italy.

Both men leaned out their window in order to see better, and ended up in the hospital when they smacked heads. *National Observer* (T. Meyer)

- Bandits trying to break into an office in Rome for a payroll robbery fired a submachine gun burst at the lock, but still did not manage to knock down the door. Finally, they gave up and fled.

Police said they had been pulling at the door instead of pushing. *San Jose News* (R. Pappa)

- Sandi Small McIlwraith was about to get into her bathtub when she heard the sound of glass breaking in her living room.

As she explains it, "I can't see too well without my glasses and I didn't have them on. I came out of the bathtub and I saw this thing standing in my living room. It was the same color as my dining room table, but I knew it wasn't the table because it had ears. I threw my housecoat on and ran out the front door and some police officers and other men were coming up the driveway. I yelled that there was a donkey in my living room and they all started to laugh. They knew it was a cow."

The laughter died as the cow charged out of another glass door and headed toward them. The posse continued chasing the cow until it was shot dead on the front lawn of another home two blocks away.

Mrs. McIlwraith asked if she could have the carcass for her freezer, but her request was denied. *Toronto Star* (J. Elliot)

A one-year subscription or the equivalent value in *National Lampoon* products will be given for items used. Send entries to: True Facts, National Lampoon, 635 Madison Ave., N.Y., N.Y. 10022. In the event of duplications, the earliest postmark is selected.

Of all menthols:

# Nobody's lower than Carlton.

Look at the latest U.S. Government  
figures for other menthols  
that call themselves low in tar.

	tar, mg/cig	nicotine, mg/cig
Brand D (Menthol)	13	1.0
Brand KM (Menthol)	13	0.7
Brand T (Menthol)	11	0.6
Brand V (Menthol)	11	0.7

**Carlton Menthol—**

**\*2 mg. tar, 0.2 mg. nicotine.**

Carlton 70's (lowest of all brands)—

\*1 mg. tar, 0.1 mg. nicotine.

\*Av. per cigarette by FTC method.

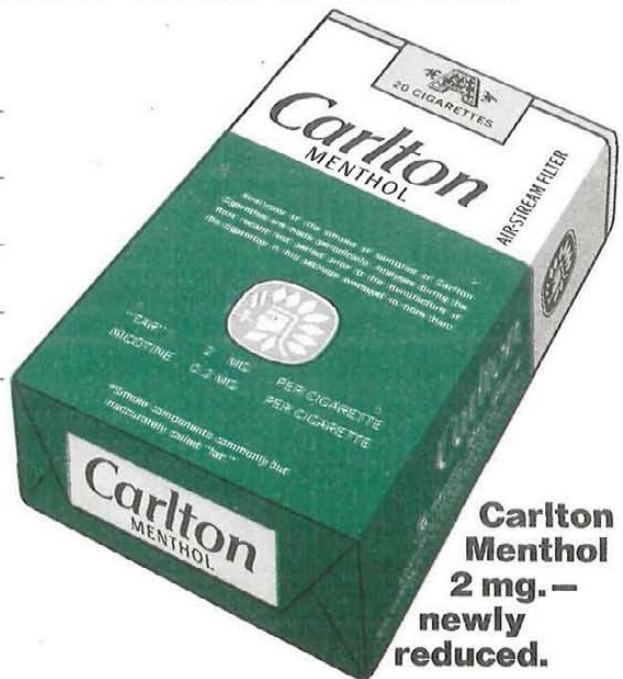

**Carlton  
Menthol  
2 mg.—  
newly  
reduced.**

Warning: The Surgeon General Has Determined  
That Cigarette Smoking Is Dangerous to Your Health.

Menthol: 2 mg. "tar", 0.2 mg. nicotine av. per cigarette, by FTC method.

# The new Sherwood S9910. Everything you hear is true.

It has all the power you need [at the lowest achievable level of distortion]: 100 watts per channel, minimum RMS [both channels driven at 8 ohms, 20-20,000 Hz], with Total Harmonic Distortion no more than 0.1%. The componentry used to achieve this rating features exceptional stability characteristics: a paralleled OCL direct-coupled output configuration . . . twin 15,000  $\mu$ f filter capacitors . . . and a zener regulated secondary power supply.

It has all the controls you need for fully flexible centralized operation: 5-position Mode switch, 6-position Selector switch, 8-position Speaker switch. Two Tape Monitor circuits [with a two-way, inter-deck dubbing capability]. Front-panel Mic Input and Mixing, with a frequency response suitable for use with a professional caliber microphone. And a Main-In/Pre-Out switch, which allows independent usage of the main amplifier section. You can operate two speaker groupings, two turntables, three tape decks and any auxiliary equipment—with no discernible white noise.

It has State-of-the-Art tuner specs: an IHF FM Sensitivity rating of 9.9 dBf [1.7  $\mu$ V]. Four-ganged tuning

capacitors, dual-gate MOS FET's provide superior image rejection and spurious response rejection, with minimal cross modulation. The digital detector introduces absolutely no distortion to the signal, and never requires alignment. The Ceramic FM IF Filters are matched for optimal phase linearity. The Phase Lock Loop integrated circuitry in the multiplex decoder improves separation and SCA rejection, while limiting distortion.

It has all the features you need for the purest sound: Loudness Compensation and Hi-Filter switches; separate detented Bass, Midrange and Treble controls [each with exceptional variance characteristics]; and a master Tone Defeat switch, for instant reference to flat response. Switchable FM Stereo Only and FM Muting. Dual tuning meters. And a Positune™ Indicator LED, which visually signals perfect tuning.

It has switchable FM de-emphasis [25  $\mu$ sec. and 75  $\mu$ sec.], to accommodate an outboard noise reduction unit. A built-in Ambience Retrieval System, which adds much of the extra coloration you get with true 4-channel sound. And a

4-channel adaptor circuit, which makes it easy to convert to the real thing.

It has plug-in driver boards [to facilitate servicing], which feature an I.C. differential amplifier input for stable operation regardless of temperature fluctuations.

It has relay speaker protection circuitry, which automatically disengages your speakers, if a potentially damaging situation arises.

It has everything we've mentioned. It has some features we haven't mentioned.

It has a price of less than \$700.\*

Your Sherwood Dealer will have it on his shelf soon. [Or if you're impatient, get all the facts sooner, by writing to us at the address below.]

Either way, it's worth waiting for.

Sherwood Electronic Laboratories  
4300 North California Avenue  
Chicago, Illinois 60618

 **SHERWOOD**  
Everything you hear is true.

\*The value shown is for informational purposes only. The actual resale price will be set by the individual Sherwood Dealer at his option. The cabinet shown is constructed of select plywood with a walnut veneer covering.





## My Meter Is Running

continued from page 18

heart and soul still belong to show business, continues Joey. So what better way to recharge the batteries, to carve out a new career, to achieve greater heights, than to do it again as a woman? What a challenge!

Joey's speech gets a lot of "Hear! Hear!"s and "True! True!"s. Peter Lawford makes the point that Frank doesn't even have to change his name that much. He can call himself Frances Alberta and sing Helen Reddy songs. In fact, a sex change will probably lighten the voice and give it more of the tenor quality it had in the fifties. Dean Martin wakes up from his sleep, puts his pinky in his ear, wiggles it in and out, and says, "You gotta admit that the ear feels a lot better than the pinky." Everybody gets a laugh out of that one, even Frank. What he's saying is that a woman gets more pleasure out of sex than a man. And since Frank is definitely not a fag and is never going to get it from behind, why not get it right? From the front. At least I *think* that's what he meant. Dean doesn't talk too clearly.

Agnew says that he can get a ter-

rific operation for Frank in Greece. He's got a lot of big connections there. Bob Hope, who has all kinds of transplants in his body, says that he can line up any female organ Frank wants, if Frank wants to go the transplant route. Evidently you can buy beautiful, healthy young female parts in Vietnam. Lots of piss-poor families are selling off their unwanted children. I know it sounds terrible, but Hope said it was true.

Sammy tells Frank he will donate any organ of his body to him, and Frank raps him on the head with affection and tells him to be quiet. Sammy is such a fucking beautiful human being. I've never seen anyone give so much love to another person. No wonder he's such a great entertainer. It pours out of him like water from a faucet. I never saw anything like it since Jolson.

Of course, there are plenty of guys at the meeting who beg Frank to stay as he is, to remain a man. Because that's the way the public knows and loves him and it would be dangerous to go against the public, even for such a star like Frank. In other words, if you're going to get an operation, get one that makes you normal again. This

is where big Jilly, one of Frank's oldest friends, starts to cry. He just can't picture Frank as a broad. Tell you the truth, neither can I. And I'm not one of his close friends.

Then everybody starts talking at once. What about all the great broads who love Frank? What are they going to do if he does a sex change? Become dykes? Will Frank become a dyke? What if his men friends start to dig him? It was getting confusing.

Meanwhile Frank is listening and taking all this in. Suddenly he sings another song, "That's Life," which immediately quiets everybody down. This is his way of telling people that he's in complete control, that he's still the boss. When he finishes the song, he looks around the room until he spots me. He snaps his fingers and calls me over. "Roll the dice," he says. "I'm betting on this dude against the house. If he wins, I become a woman. If he loses, I stay a man, no matter what happens to my body."

He reaches up on a shelf and finds a pair of fresh dice. I'm the guy with the hot hand and he decides to put it all on me. A roll of the dice is going to decide his fucking fate. Jesus.

continued

Life was blank.  
The Music Tape™ by Capitol  
was blank.

The Music Tape is the  
premium blank tape  
made for recording music.

Sound gatherer... music giver.  
Now I'm attuned to life.

When you record music, make sure you get  
all the color. Record on...

# Brut for Men.

If you have  
any doubts  
about yourself,  
try  
something else.



After shave, after shower, after anything.  
Brut® lotion by Fabergé.



## My Meter Is Running

*continued*

What a fantastic son of a bitch he is. No tears, no bullshit.

Of course, Frank has no idea of how much I love him. He thinks I'm just a lucky guy with a hot hand. But I figure it this way: I know I can win. I know I can beat the house with ease. But if I do and Frank becomes a woman, the world will be deprived of the greatest guy in show business. I can't let this happen. So I roll a four. An easy four. A chippie. I do fours in my sleep with one hand tied behind my back. Then I throw a few other numbers to make it look good, and bingo...I crap out. I lose.

For a couple of seconds the room is completely silent. Then a big fucking sigh comes out of everyone. Sammy can't stop crying, so Frank tells him to get up and dance. In fact, everybody is crying, including me. This is what we all really wanted for Frank. We're crying tears of happiness. Frank looks at me and gives me the tiniest wink and then a big smile. He turns to big Jilly and says, "Call Dr. So-and-So in Switzerland. Tell him to get the goat glands ready. Ol' blue eyes ain't finished yet."

So Frank decided to cut out all this sex change bullshit and get more masculine stuff into his system. It's like a tonic, he told me. You feel like a bull, only they use these glands from baby goats that come from someplace in Tibet.

Then Jilly picked up the phone and called an army of broads, and before long we had a real party going. I can't remember much, but all I know is, I had to wear a full jar of Vaseline around my shvance for the next three days, that's how worn out it was from shtupping. I do remember humping this broad right next to Frank and his broad and they both stopped to watch me and when I was finished they applauded. Frank said I was his buddy for life. I was part of the family from now on. Any time I needed a favor—anything—just pick up the phone. It was the happiest moment of my life.

The only thing that spoiled my time in Vegas was the run of bad luck I had the next night. To make a short story even shorter—I blew the fucking fifty G's Frank gave me, plus almost all of Cher's \$5,000 tip. First time in my life it ever happened. I walked out of Vegas with \$9.86. I didn't give a fuck. As Frank says, "That's Life." □

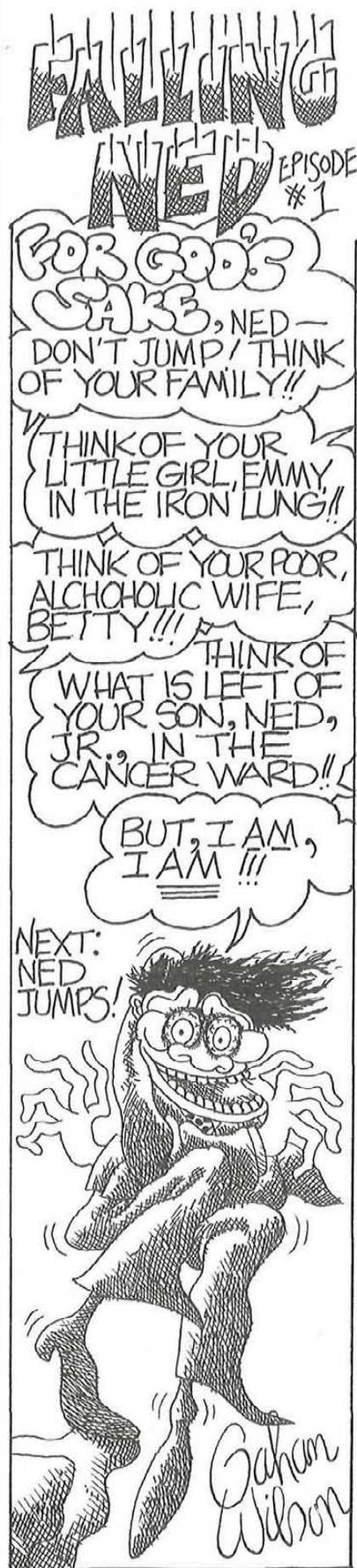

## Canadian Corner

continued from page 27

trader and made the meet in Big O's HQ, outfit called Pulp Press. Gave the Marx Maven a mood ring on meeting and kept an eye on it during interrogation.

He seemed pretty pissed about election result. Speech colored with anti-free enterprise statements. Published poster encouraging burning of public buildings. Written in slightly stilted, anachronistic style experts later identified as Canadian poetry. Mood ring read burning blue truth. No CIA connection.

Plotted next move over drink with hand puppet, Lysander. Muff puppet grabbing waitress's ass—won't take him to nice place again. Decide to invite self to party. See girls in long dresses, lots of mood rings, horny, too...place blue as a moonscape. Couple of preteens smoking hash, this place is hipper than Smallville, Superboy's birthplace. Spot first Agency OP at punch bowl. Brooks Brothers blazer altered to dress on the left for quick hot lead whip and flips, silver fountain pen, bridgework looks European. Use Lysander to get him talking.

"What are you on?" Bad question. Secret agentleman crosses his eyes and says, "Hash." Yuk. "Case? Assignment?" I flash Harvard ring (unredeemed pledge I. Farber Loans). Operative tries to steer me to closet for debriefing, forced to refuse, not knowing top secret class of '68 sphincter code. Gave Double-O Seconal a nose full of truth powder and he started talking like talk show hostess Tom Snyder during total eclipse of the intelligence.

It appeared CIA activities in Canada consist of fishing, dinner dancing, skating, hunting, etc. They had been in the country since the previous October, when agents brought back reports of excellent duck hunting in the area. These reports aroused much interest in Virginia—at a very high level. As for interference in local government, Cloak and Bull Dagger pointed out: "Most of these people have finished high school. They know you don't get things changed by attacking Green Berets with shovels. No, we just use this place for fishing." Left party early: Expenses \$38 American for food and wines consumed by lady who bunked my snake.

Woke up in the morning, felt like a kitten had been playing with my cere-

bral arteries. Made resolution to stay off the bottle. Need steady nerves for my kind of work, and you don't get them from the bottle, not for long. Lots of writers been ruined by the bottle. Guys like Dylan Thomas, who had the world bent and greased, wound up being dragged across vacant lots by giant spiders.

Went thrush shooting with *National Lampoon* tree farmer. Says he'll be able to supply us with plenty of paper if he can keep his friends' kids out of pickup trucks. Accidentally shot Italian who was throwing thrush from behind a bush. Shouldn't have shouted till the birdie was out of his hand. Buried with full honors and two witnesses same afternoon. Tree farmer leaves for Mexico next day. Says their secret police are so nice down there.

Visit Whistler Mountain ski resort to track down rumor of CIA mata horny masquerading as blond waitress in Ski Boothole hotel, sucking downhill wax formulas out of dog-butt licking drunk ski instructors. Might be true. Expenses: Graval, \$1.25.

Headed for airport next day, caught Air Canada's (flying subway) Politicians' Special to New York (free Cuban cigars, all the champagne you can drink, in flight homo fuck films). Lysander talked way through customs. □



"GUESS WHO!"

## Brut 33 Deodorant for Men.

### You won't have any doubts about yourself.



Brut 33®—the deodorant spray  
with the great smell of Brut.®



# Our new storage system. A safe place for your cassettes to live.

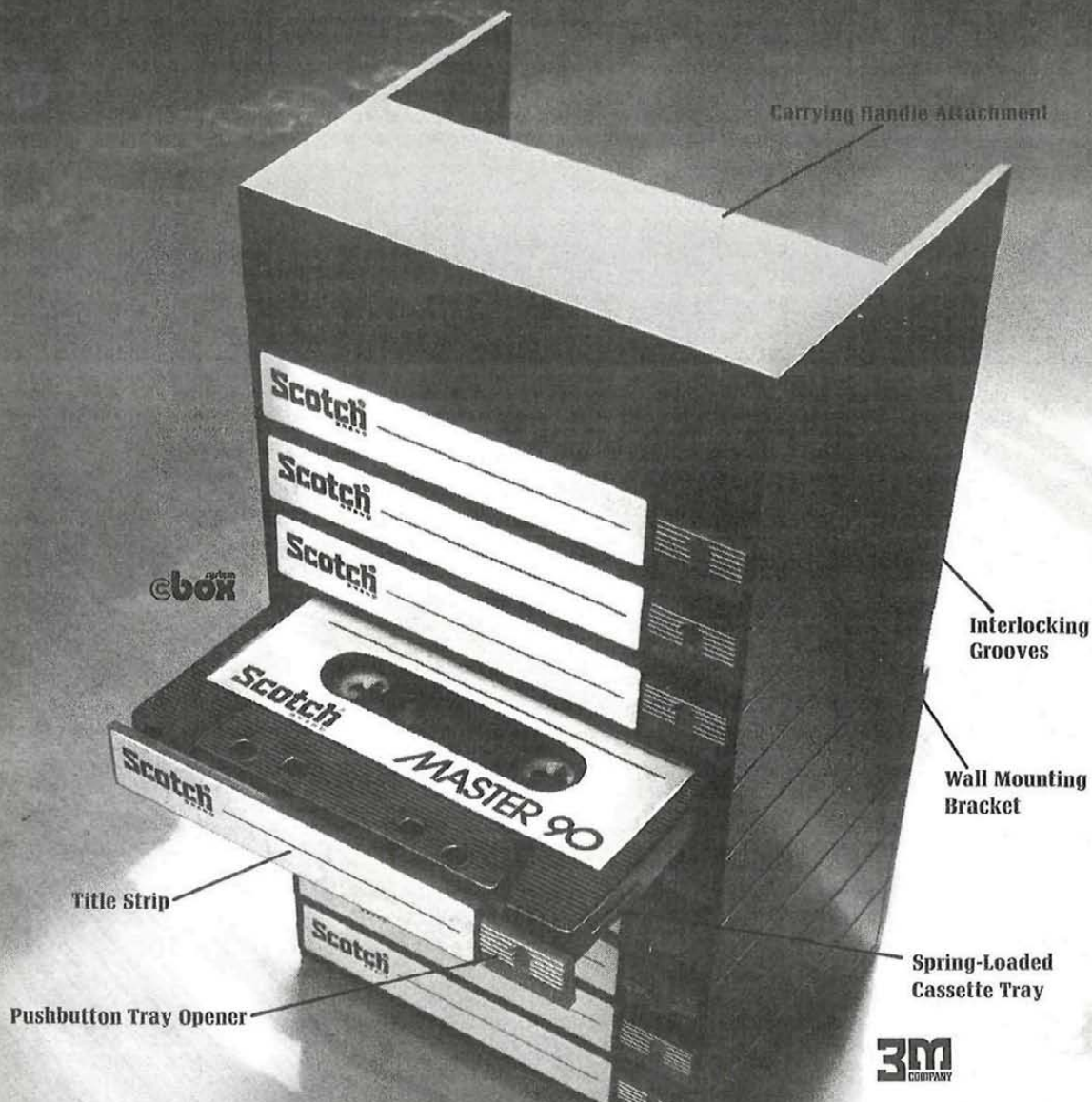

If you've ever lost a cassette or laid one down where it's been ruined, you'll really appreciate the new C-Box.™ It's a convenient way to store your cassettes. And it's available only with Scotch® brand cassettes.

At the touch of a button, a tray pops out of the C-Box, exposing your cassette. And one C-Box interlocks on top of any other C-Box. So you can stack them as you add cassettes to your collection.



**Scotch® Cassettes.**  
They just might outlive you.

You can even add a carrying handle and mounting bracket.

Of course, a Scotch cassette can live a long life even without a C-Box. Because there's a Posi-Trak® backing to help prevent jamming, a plastic cassette shell that can withstand 150°F heat, and a tough magnetic coating that can deliver great sound quality even after hundreds of replays and re-recordings.

Now that we've got the new C-Box, is there no stopping us?

# The Clubowner's Newspaper

## The Sportbiz News

APRIL 8, 1976

\$6.50

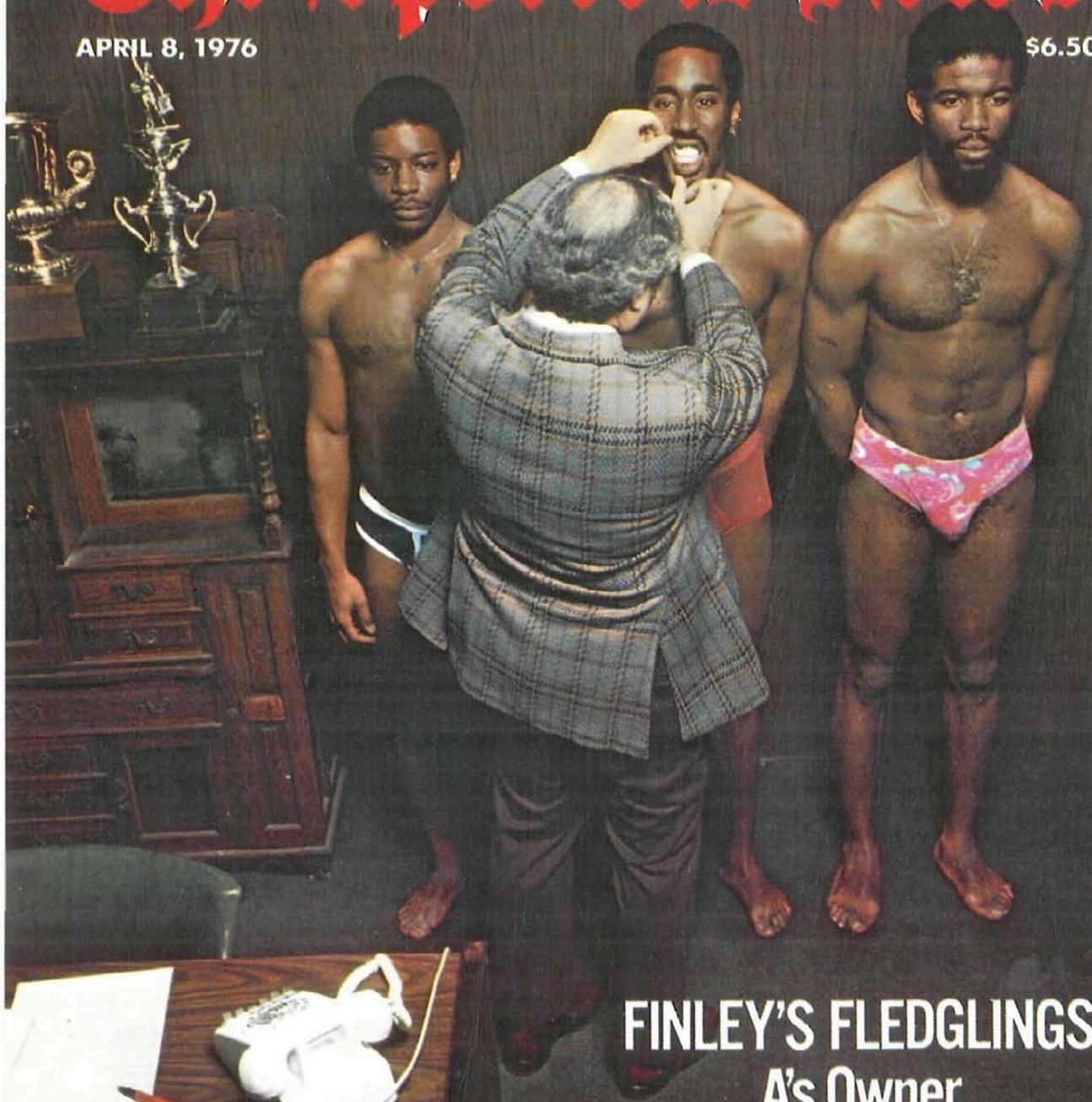

**FINLEY'S FLEDGLINGS**  
A's Owner  
Sees Big Bucks  
for Coming Season



## we believe...

By C. C. PIDDLE SKINK  
Editor and Publisher

### Battle Royal over the New Play-off System

ST. LOUIS—As the fathers of pro football gather for their annual meeting in Sea Island, Georgia, they'll be mulling over whether or not to accept Commissioner Pete Rozelle's dramatic new proposal for a revised NFL play-off system. While the plan makes eminent good sense—executives of the three major networks and the entire Board of Directors of the Goodyear Tire and Rubber Company have already endorsed it—internal wrangling over the exact details of Rozelle's program threaten to delay its implementation indefinitely, if not to kill it altogether.

Virtually every one of the 28 league owners agrees, of course, with the bare bones of the plan, loosely based as it is on the already proven formula adopted many years ago by the National Hockey League. In brief, the first-place team in each division, instead of proceeding automatically to the NFC or AFC semifinals, would first have to confront—and defeat—the fourth-place team in its own division. The second- and third-place teams would,

meanwhile, play off against each other for the right to take on the first- or fourth-place finisher in a do-or-die struggle for a berth in the conference quarterfinals.

THE TRADITIONAL FIGHT for wild-card positions would, naturally, take on an added dimension with this year's expansion of the NFL to Tampa and Seattle. The presence of the two new franchises creates four five-team divisions—two in each conference. The result: exciting “no-tomorrow-for-the-loser” encounters between the two fifth-place teams in the NFC and the AFC for the privilege of opposing one of the survivors of the respective quarterfinal battles in the “win-or-go-home” semis.

So far, so good. But here's where the controversy comes in. Rozelle and the more forward-looking owners feel that the conference semifinals and championships ought to be best-two-of-three-game affairs, with the Super Bowl being extended to a three-out-of-five game format. “At last we'd have a *true* test of which team is

best,” comments New York Giants' president Wellington Mara, one of Rozelle's most vocal supporters.

But several other executives, no doubt concerned about the somewhat negative reactions to the Commissioner's proposal, voiced by such lunatic-fringe “liberal” writers as Tex Maule, Red Smith, and Joseph Durso, apparently fear that a 13-game post-season juggernaut to the championship might be a bit too exhausting for even the staunchest players and fans. (Did Messrs. Maule, Smith, and Durso ever stop to consider, we're tempted to ask, where *they'd* be today if all sporting—and sports *writing*—activities were conducted on a strictly amateur basis?)

OBVIOUSLY, WE DON'T AGREE with this more timorous position. But, in reality, we don't feel that the gap between the two sides is too great to bridge. Perhaps a viable solution lies in Oakland Raiders' owner Al Davis's compromise proposal: limit the four intraconference rounds to only one game each, institute a best-of-three-games series to decide the Super Bowl Championship, and resuscitate the annual Play-off Bowl Game between the NFC and AFC runners-up.

Only one thing is certain: if continued hassles between club executives prevent the adoption of at least some of Pete Rozelle's ideas, not only a great sport, but the media, the sponsors, and the owners themselves will be the big losers.

## Owners Fear Supreme Court Decision Will Go Against Them, Prepare New Appeal

In a grim, businesslike convention held in Acapulco, the Baseball Owners' Association developed a brilliant new position for their expected appeal to the Supreme Court concerning their exemption from anti-trust laws.

Lawyers for the association have prepared a brief based upon a redefinition of baseball as a religion. The main points of the brief are: (1) baseball is an activity that brings large

numbers of people together to worship in temple-like structures; (2) the services are celebrated by small numbers of people for the faithful; (3) the faithful worship athletic “Gods,” idols, relics in the Hall of Fame, and other totemistic objects; (4) baseball as a religion brings people together in spiritual harmony, good will, and moral uplift; (5) most important, baseball makes money, a great deal of money.

THE OWNERS INTEND to create the First American Church of Baseball. This will mean that all baseball income will be tax-exempt. Players will be designated as clergy and therefore become volunteer workers, “married to the church” and hence unable to organize and bargain collectively.

“Whoever heard of a priest's union?” sniffed Walter O'Malley, as he grinned happily and



Justice Burger

downed his fourteenth Margarita from a brand new silver chalice. O'Malley will be the first Supreme Pontiff appointed by the Church of Baseball.

## American League Changes Criteria for MVP Selection

SARASOTA, FLA.—By a lopsided vote of 14-6, the American League owners elected Tuesday night to change the criteria by which the league's most valuable player is chosen each season.

Traditionally, the MVP winner has been that player who, in the opinion of the Baseball Writers of America, has been

“the most instrumental in his team's success.” In the future, however, the MVP award will go to the man who “best combines a reasonably respectable batting or pitching percentage with a low annual salary.”

“THIS NEW RULING gives the little guy a chance, the guy without the high-paid agent, the guy who maybe

didn't hold out for some five- or six-figure salary,” enthuses Yankee owner George Steinbrenner, whose enforced leave of absence from baseball, the result of an illegal presidential campaign contribution, necessitated his casting his vote by proxy. “I think it's a great thing for the game.”

In 1975, the American

League MVP, the last to be selected according to the old standard, was Boston Red Sox rookie sensation Fred Lynn. Had the new system been under effect, the winner would have been Kansas City Royals reserve infielder Freddy Patek—“a much more deserving choice,” according to Steinbrenner.

# Burke Takes Lead in Lunch League

In a burst of eating, drinking, and telephoning, Mike Burke of the Rangers and Knicks swept into the lead in the Owner's Expense Account Lunch League this week. Burke spent \$28,873 in one week to beat out Jack Kent Cooke, Bill Veeck, Carroll Rosenbloom, Don King and Ray Kroc.

**BURKE'S GRAND TOTAL** of \$123,632 in one month has already earned him a booth in the expense account regional play-offs, to be held in New Orleans. Burke took his commanding lead with typical brio and élan by ordering Laffitte Rothschild '06 with everything. '06 had to be flown in from Guy Rothschild's private stock and cost \$500 a bottle. When security guard and corkage charges were added, the total came to roughly \$1,100 per bottle.

"Most of the guys in my league just order Bloody Marys or martinis for the house. They don't know shit from Shinola about vintage wines. By the end of the

## expense accounts

by DAVE TISCH



lunch, they're straining—they're hiring limos. Lear jets, they're getting double manicures, haircuts on top of haircuts—anything to get their totals up. Me, I just call my friend Guy, who I know from my OSS days, and order a couple of cases of '06 or '07. Hell, caviar costs only \$200 a bucket and filet mignons are dirt cheap. If you're going to win, you've got to know your wines and your brandies."

The ever-generous Bill Veeck almost drew even with Burke, but was penalized an entire week's total because he used some of his own money. Ray Kroc continues to run last by insisting on using his own McDonald's franchises for his lunches. "I end up *giving* everybody a

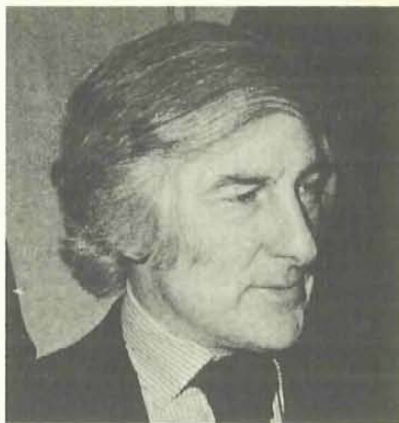

Mike Burke

franchise. That's how I entertain my clients," said Kroc. But franchises don't count.

**NOT TO BE OUTDONE** by Mike Burke's Laffitte Rothschild gambit, dark horse Don King plies his guests with soup bowls of 99 percent Columbian rock coke. The ploy ups his total but backfires when guests completely lose their appetites.

## OEALL current standings

	FOOD	DRINK	TAXIS/LIMOS	TELEPHONE	GROOMING	MISC.	TOTAL
Mike Burke	\$6,009	\$13,200	\$750	\$2,300	\$1,776	\$4,838	\$28,873
Jack Kent Cooke	\$7,179	\$3,900	\$4,030	\$3,700	\$5,741	\$1,350	\$25,400
Don King	\$112	-	\$2,800	\$4,777	\$7,300	\$8,400	\$23,389
Carroll Rosenbloom	\$5,400	\$3,300	\$3,150	\$3,804	\$5,690	\$1,370	\$22,714
Ray Kroc	37¢	-	-	-	-	\$17,000.37	\$17,000.37

## "Br'er" Bares All

# Secret of His Success

In the football coaching fraternity, "Br'er" Byron's recruiting incentive program is the envy of the business. Every coach has tried to copy "Br'er's" imaginative distribution of largesse, including guaranteed passing grades, lucrative employment for parents, relatives, and friends, bonuses, tax-free gifts, long-term investment programs, stock portfolios, annuities, cars, houses, appliances, Swiss bank accounts, and outright cash bribes. But these incentive ideas can be used by anyone. How is it that "Br'er" always manages to pull ahead of his colleagues in recruiting the cream of the high school crop?

"It's simple," said "Br'er." "I give the best God-damn blowjob in college ball.



"Br'er" in Action

## amateur section

by STAN STOKES



And I can hold them from coming for hours. Round the world three times."

Recently, "Br'er" has dropped the color line and started an intensive recruitment program with Negro athletes using the same technique.

"All my coaching career I've used this technique as part of the business, something I had to do for the school," said "Br'er." "But you know something, with these jigs, I've even come to enjoy it."

"Br'er" first heard about the technique from someone who had played under the legendary Knute Rockne. It seems that along with Knute's fiery, inspirational half-time pep talks went a massive oral gang bang starring Knute's mouth. The silver-tongued orator

passed along all the finer points of his legendary technique to "Br'er" on his deathbed. "In fact, old Knute was doing me at the moment he kicked off. I came in his mouth as he died in my arms."

The only person "Br'er" has revealed his invaluable secret to is someone who must remain anonymous. "All I can say is, he lives in a wheelchair and he put my advice to good use."

**NOW THAT "BR'ER"** has bared his secrets, we have no doubt that every college coach in the land will soon be emulating his style. But without a doubt, "Br'er" will be coming up with something new. Whatever it is, there's no doubt that "Br'er" Byron will go down in history as the most innovative recruiter in football.

## Mike Burke

# You Pay More, You Get Less

Amazing Mike Burke, owner of the N.Y. Rangers, is this week's pick for sassiest \$-maker. Burke's basic motto is big bucks, no pucks. His team is bottom-rated in the NHL, yet he still charges the highest ticky-tabs in North America and gets away with it. How does he do it? Simple, sez Burke. "This city of finalists cr-p is a load of cr-p. City of no-shows is more like it. They love losers. Look at the Jets. Look at the Giants. Look at Beame. Look at Moynihan. And they're lazy, lazy, lazy. Think they're going upstate to Buffalo for good hockey? Forget it. Hell, they won't even drive out to Nassau to see a decent team. They'll come to the Garden, same way they go to the nearest deli for some Jew-food that'll give 'em acid for a month. They love pain. And I make 'em pay." Burke doesn't stop there, though. He's set up an army of scalpers who can boost tickies by 200, 300 percent simply by hanging round the Garden five minutes before the debacle. They're all black. "Everyone knows there ain't a boogie that would be seen dead at a hockey game. They figure these guys mean business. So they pay." Burke takes a 50-50 split with all scalpers, and plows it right back into blue chips and preferred debentures. "No more muni-bonds, though," quips Burke.

**HE DOESN'T STOP THERE, EITHER.** New policy at the Garden is to load the beer containers with shaved ice. "I do it with Coke. I do it with 7-Up. Why not with beer?" He gasses up beer profits with heavy doses of salt in peanuts and popcorn sales. "A quarter pound of salt in every jumbo popcorn container costs you a half a cent, gives you five more beer-on-



Mike Burke

the-rocks buys than you'd normally get. Two cents of beer over three cents of ice gives you 1500 percent profit on a seventy-five cent beer, times however many cartons of salted popcorn or peanuts you

## owner of the week

by HERB HELZEL



can sell," says Burke. "I stock about \$200 worth of beer and cats for the whole game, enough to take care of everyone, and walk out with 100,000, 150,000 bucks for the night."

**SBiz NEWS ACCOLADE** also goes to Jets owner Phil Iselin, who apparently kept Winston Hill, Namby-Namath's bodyguard, going through an entire season even though he was legally dead. Seems that Winnie suffered terminal contusions of the head, hips, arms, and internal organs early on in the season against the Buffalo Bills, but was still kept on the squad. Winnie was medically dead by midseason, having no idea of where, who, or what he was, but despite coach Winner's buck-cating protests, was still propped out on the field to "protect" Joe Willie. By the Miami game, Winnie the Poop was a corpse kept on ice through the week and held up during Namath's hopeless plays by a guard and center. Iselin saved not only on replacement costs, but also managed to avoid air-freight fees for shipping the 300-pound-plus stiff back to his folks by having him cremated. Winnie was mailed third-class to his final resting place in a manila envelope at a cost of only 8 cents. All hail to Phil Iselin!

## Al Barato

# You Pay Less, You Get More

Albert Barato, defensive lineman of the Edmonton Eskimos and SBN's Player of the Week, loves to play football. "Heck," says Big Al. "I know that I'd probably be picking vegetables somewhere if I weren't doing this. Every morning I get up and thank the Lord that I've been given the fortunateness to do what I like. Gettin' paid for it, too."

**IF THAT SOUNDS TOO GOOD TO BE TRUE** in this era of super bucks and high living, well, that's just the kind of guy Big Al is. Just last month Al suggested a voluntary pay cut for himself so that his team would have the money it needed to attract a quality quarterback. "Look," says Al, "big hunks of mutton like me are a dime a dozen, but a main man with the big arm is worth paying for, and it'll be good for me in the long run."

Al trusts his owners and his owners trust him. "Contract?" queries Al. "What's that? I don't even need a handshake. It'd be a helluva thing if you couldn't trust your own front office. I mean, we're all on the same team."

Al is somewhat of a homebody who

doesn't go in much for the social whirl. As he puts it, "I know I'm no Joe Namath, so I don't go out much. But that's okay with me. This way, I get to babysit for General Manager Vern La Folliere, who is a swell guy. He gives me his old suits and often slips me an extra five or ten when I do some odd jobs around the house."

**THERE'S NEVER A WORRY** about Big Al missing a bed check or running around the night before a game. In fact, Al has never stayed out past ten o'clock even once on his whole life. Last season he lent management a big helping hand by turning in a list of every player who missed a bed check or came in smelling of alcohol. "What you do on your own time is your own business," said Al, in a rare, philosophical mood. "But during the season, we're all like trucks in the owner's fleet. Putting alcohol in your body is like making number one in the boss's gas tank."

There's one story that typifies the courage and self-sacrifice of Al Barato. It's a story that Al himself is fond of telling. "It was two days before an important game, and the dummy had already broke in practice.

## player of the week

by TIM SPOKANE



There was no way we could replace it. What were we gonna do? Skip tackling practice? Not on your life. I volunteered to



Al Barato

take the place of the dummy and we had some really good workouts."

Al Barato a dummy? Not on your life! Hats off to Player of the Week, Al Barato!



# Chris Hemmeter, Former Commissioner of Defunct WFL, Sets New Track Records

by FRANK DEMPSTER

The Olympic Track and Field Committee is setting envious eyes on the exploits of Chris Hemmeter, former commissioner of the World Football League. Hemmeter has been setting all sorts of unofficial records in virtually every track event as he consistently evades the hundreds of WFL creditors who have not been paid.

*Sportbiz News* sped alongside Hemmeter on a motorcycle as he ran rapidly down Madison Avenue in Manhattan, far ahead of an army of ex-WFL suppliers. "I'm talking about your basic suppliers," said Hemmeter, as he sprinted the 440 in 37.5 and ducked into a clothing store. "I'm talking about the people who made the uniforms, the equipment, the AstroTurf. I'm talking about the

stadium contractors, the architects, the PR people, everybody who made their living off the WFL. We owed them all."

Hemmeter has already done a respectable 3.56 mile, a high jump of 7 feet 6 inches into an open window of a first-floor apartment and a running broad jump of 27 feet over five parked cars, giving his creditors the slip every time. He also did the 40-yard dash (the ultimate sprint test for football players) in two flat.

**RETURNING TO MADISON AVENUE**, Hemmeter suddenly found himself surrounded by police, U.S. marshalls, and another army of creditors. Before anyone could say "Larry Csonka," a helicopter swooped down to an alarmingly low level and Hemmeter pole-vaulted right onto a wait-



Chris Hemmeter

ing ladder, a vault of at least 30 feet.

Hemmeter doesn't need any pep pills to break records. "To

paraphrase Mel Brooks, fear is the best drug," he yelled, as the helicopter took off for places unknown.

# Jets Trade Namath in 15-Way Deal

by BOB O'MARR

The New York Jets traded Joe Namath to the Los Angeles Rams for Lawrence McCutcheon, Ron Jaworski, and three draft futures. The Rams promptly traded Namath and Harold Jackson to the Oakland Raiders for Ken Stabler and \$100,000 worth of soybean futures. The Raiders sold the futures to the San Francisco 49'ers for a half interest in parking lot number nine at Disneyland in Anaheim. Commissioner Rozelle ruled that the parking lot was officially a free agent and the 49'ers had to be further compensated. In compliance, the Raiders also sent the 49'ers retired quarterback John Brodie and two magazine rack slots next to the cash registers in the Safeway supermarket chain. The 49'ers needed a running back desperately and were forced to trade the magazine racks and Gene Washington to the Minnesota Vikings for Chuck Foreman. The Vikings immediately sent

the magazine racks to the New York Giants in exchange for TV station WPIX and negotiating rights to Gladys Knight



Gladys Knight and the Pips



Grand Central Station

and the Pips, whose contract was still owned by the Detroit Tigers. In this trade, baseball Commissioner Bowie Kuhn ruled that the Giants had to compensate the Tigers by financing a new domed stadium in Grosse Point, while the Vikings will share in the net income of the refreshment concessions and will get two players to be agreed upon at a later date. If Namath fails to report to the Rams (as rumored), they will receive a 50 percent share in the new Budweiser brewery, to be built in Puerto Rico. If the new stadium in Grosse Point is not completed by 1980, then the Tigers must forfeit all rights to Kareem Abdul Jabbar and leave him free to negotiate a new contract with any team he desires in any sport he desires. To compensate the Jets on their possible loss of Joe Namath, he will be returned to the Jets in exchange for Toots Shor and air rights to Grand Central.



# NEGRO CORNER

by Don King

Latest Don King SuperDeal: Muhammad Ali vs. the winner of the George Foreman-Sequoia tree fight. The bout is slated for Redwood National Forest, where King guarantees a crowd of over twenty million and a gate of five or six billion. Plans for the clearing of 1,000 acres of redwood forest are now pending, with King entertaining bids from Weyerhaeuser and Champion Paper for the tree cutting. Ali is guaranteed

10 percent of the lumber rights. **ITCHY INDUSTRIALIST** Don King interviewed at breakfast over mucho deals: "I like my eggs over easy." Don also digs hushpuppies, cherrystones on the half shell, and lots of brown rice.

Superbusy Don King's newest brainchild: contact bridge, a new sport that combines bridge with basic techniques of football and boxing. King sees a big identification

thing from inner city residents with social climbing aspirations and deep-seated feelings of violence. "My people still got a lot of inner conflicts, and contact bridge will resolve them. Especially at \$12.50 a ticket." Your bid, Don!

Heavy rumor department: Old but still lovely Coretta King and Don "Superguy" King. Don says: "It cuts down a lot on my paperwork." And speaking of paperwork, Coret-

ta adds: "I don't have to change my stationery."

**WHAT'S DON KING UP TO NOW?** "Whuppin' Ass." a new sport which promises to fill those coffers once again. The idea is simple. Lure about 50,000 Negroes into a small, uncomfortable arena, charge high ticket prices, tell them there's going to be some heavy action, and lock all the doors. When the nig-nogs discover that nothing is going to happen, they'll make things happen all by themselves. Knife fighting, rioting, bottle fighting, gunplay, and assorted violence is guaranteed. Hidden cameras will record the mayhem for thousands of theaters all over the world on closed circuit TV. "Needs no overhead," says dapper finger-on-the-pulse Don. "In fact, it's what the whole world wants to see."

## Tragedy Averted as 77,000 Die in Stadium Collapse

by JACK LURID

CARSON CITY—"It was horrible, really horrible," said stadium builder Dominic Stromboli as he emerged, tired but victorious, from a marathon courtroom ordeal arising out of the collapse of recently completed Comanche Stadium in Carson City, Nevada.

**STROMBOLI CONCEDED** that he had submitted a "low ball" bid for the \$25 million sports complex. "But," he went on, "that kind of thing goes on every day. What really ticks me off is the way the city fathers refused to play ball with us on cost-overruns. For another ten or twenty million, tops, we could have made extra sure that this kind of thing never happened."

Stromboli refused to accept any blame in the collapse. In angry words, he defended his choice of adobe construction materials, adding, "It's a tried and true way of doing things out here in the West."

Sol Gelb, the attorney for Stromboli's Bilt-Well Construction Company, described his client as "a man who is worried sick that all this irresponsible bad-mouthing from city hall will cost him a pile of money."

**ACTING** for Stromboli, Gelb instituted a \$4.5 million

libel action against the Municipal Corporation of Carson City. In a tear-soaked summation speech, Gelb got down on his knees and cried as he explained, "My client is a sensitive man. How do you think he

felt at the sight of all this blood and gore? It had to affect him. But this disaster is bad enough without bringing name-calling into it."

Judge Martin Craven, who is also the county sheriff, ruled in

favor of Bilt-Well. Saying that he wanted "to put all penny-pinching city hall gossips on notice," Craven added \$5 million to the settlement package for "pain and suffering" experienced by the injured party.

## pro basketball box scores

### GAMES OF TUESDAY, MAR. 25 SEATTLE AT NEW YORK

Gulf + Western's New York Knickerbockers, already leading the NBA Atlantic Division in gate receipts, added to their first place margin when they packed 17,209 paying customers into Madison Square Garden for a game against the Seattle SuperSonics. The Garden box office, with the aid of some last-minute heroes from the Palermo Theater Ticket Sales Service of Union, New Jersey, overcame a 2,000-plus unsold situation in the first and second promenades by artfully selling out the loge and mezzanine sections.

#### TICKET SALES

Loge	Price	Sold	Receipts
First Promenade	\$12.50	3,800	\$47,500.00
Second Promenade	12.50	1,973	24,662.50
Upper Mezzanine	10.00	1,986	19,860.00
Lower Mezzanine	8.50	4,125	35,062.50
Roof-top Box Seats	8.50	4,125	35,062.50
	12.50	1,200	15,000.00
<b>Totals</b>		<b>17,209</b>	<b>\$177,147.50</b>

No shows: 412 Press and other nonpaying tickets: 103 TV and Radio Income: \$14,325.54

#### CONCESSION SALES

	Price	Sold	Receipts
Beers	\$.75	11,114	\$8,335.50
Hot dogs	.50	13,871	6,935.50
Programs	1.00	9,651	9,651.00
N.Y. Kn'k'rb'k'r S'n'y Rabbits' Feet	1.49	987	1,470.63
N.Y. Kn'k'rb'k'r Bouncing-Head Dolls	5.00	311	1,555.00
Misc.-69-29.95			10,284.69
<b>Totals</b>		<b>38,506</b>	<b>\$38,232.32</b>

### GAME OF WEDNESDAY, MAR. 26 SAN ANTONIO AT DENVER

A rare overtime, plus an experimental ten-minute break between quarters, combined to

### NBA STANDINGS Through Games of March 30

#### EASTERN CONFERENCE ATLANTIC DIVISION

Club	Attendance	Revenue	Pct. of Capacity	\$ Behind
New York	692,865	\$7,275,082.50	853	\$
Boston	560,021	5,040,189.00	772	2,234,893½
Philadelphia	548,653	4,663,550.50	711	2,611,532
Buffalo	491,860	3,934,880.00	525	3,340,202½

#### CENTRAL DIVISION

Club	Attendance	Revenue	Pct. of Capacity	\$ Behind
New Orleans	729,961	\$5,109,727.00	677	\$
Cleveland	681,294	5,109,705.00	649	27
Washington	413,337	3,306,696.00	551	1,803,031
Atlanta	247,176	1,858,820.00	312	3,250,907
Houston	197,882	1,780,938.00	292	3,328,789

#### WESTERN CONFERENCE MIDWEST DIVISION

Club	Attendance	Revenue	Pct. of Capacity	\$ Behind
Milwaukee	454,861	\$3,411,457.50	601	\$
Chicago	218,742	1,749,936.00	325	1,661,521½
Kansas City	221,111	1,658,332.50	326	1,753,125
Detroit	216,434	1,623,255.00	314	1,788,202½

#### PACIFIC DIVISION

Club	Attendance	Revenue	Pct. of Capacity	\$ Behind
Los Angeles	512,671	\$5,254,877.50	717	\$
Golden State	477,456	3,819,648.00	812	1,435,229½
Seattle	452,367	3,392,752.50	714	1,862,125
Portland	439,214	3,294,105.00	681	1,960,772½
Phoenix	299,044	2,242,830.00	329	3,012,047½

# DOGFISHING IN AMERICA

by Gerald Sussman

photographs by Matthew Klein

**T**he jukebox at the Pez Dorado on Second Avenue and 116th Street has a surprisingly eclectic selection for a bar deep in the heart of Spanish Harlem. Between your basic salsa we find such foreigners as Frank Sinatra, Otis Redding, Bob Marley, LaBelle, even Paul Simon. It's Friday night. The noise is happy—classically orchestrated. No random violence. Maybe later. Just lots of cheap rum, cheap beer and Puerto Ricans. And tucked between your basic PR's we see jet setters, chamois-suede safari-suit types, jock superstars, groupies and party people (yes, there's Jimmy Caan with Lauren Hutton and Herman Badillo). This is why the jukebox has broken the ethnic barrier. The Pez has gone cosmopolitan and, dare we say it, chic. It has become *the* hangout for the dogfishing set.

Roberto Valdes, known as "the baboon" because he likes to wear animal costumes, is the unofficial host and mayor of the Pez. Roberto has an odd walk—a hop, actually. His right leg is stiff and extends off the ground. He is a man who likes to mix street *patois* with high-class words picked up God knows where. For a double Ron Llave, Roberto will tell you how dogfishing started.

"The Puerto Ricans started the whole dogfishing sport, you see," said Valdes. "You know why? Because of the dogshit. The fa-ha, we called it. We couldn't walk in the streets for all the dog *merde*. We're clean people. It was those canines that made our streets dirty. So we bought some cheap fishing rods and used *cuchifritos*, that's fried pork stuff, for bait. We used to catch hundreds of dogs casting from the windows of our cars. We caught the newspaper dogs. You know, those cheap little mutts you see in the window of the pet shop on the cut-up newspapers. That's mostly the kind of dog my people could afford. You throw out your line and pretty soon, bow-wow, you got a newspaper dog. Then we drive like crazy to someplace like the East River and dump them.

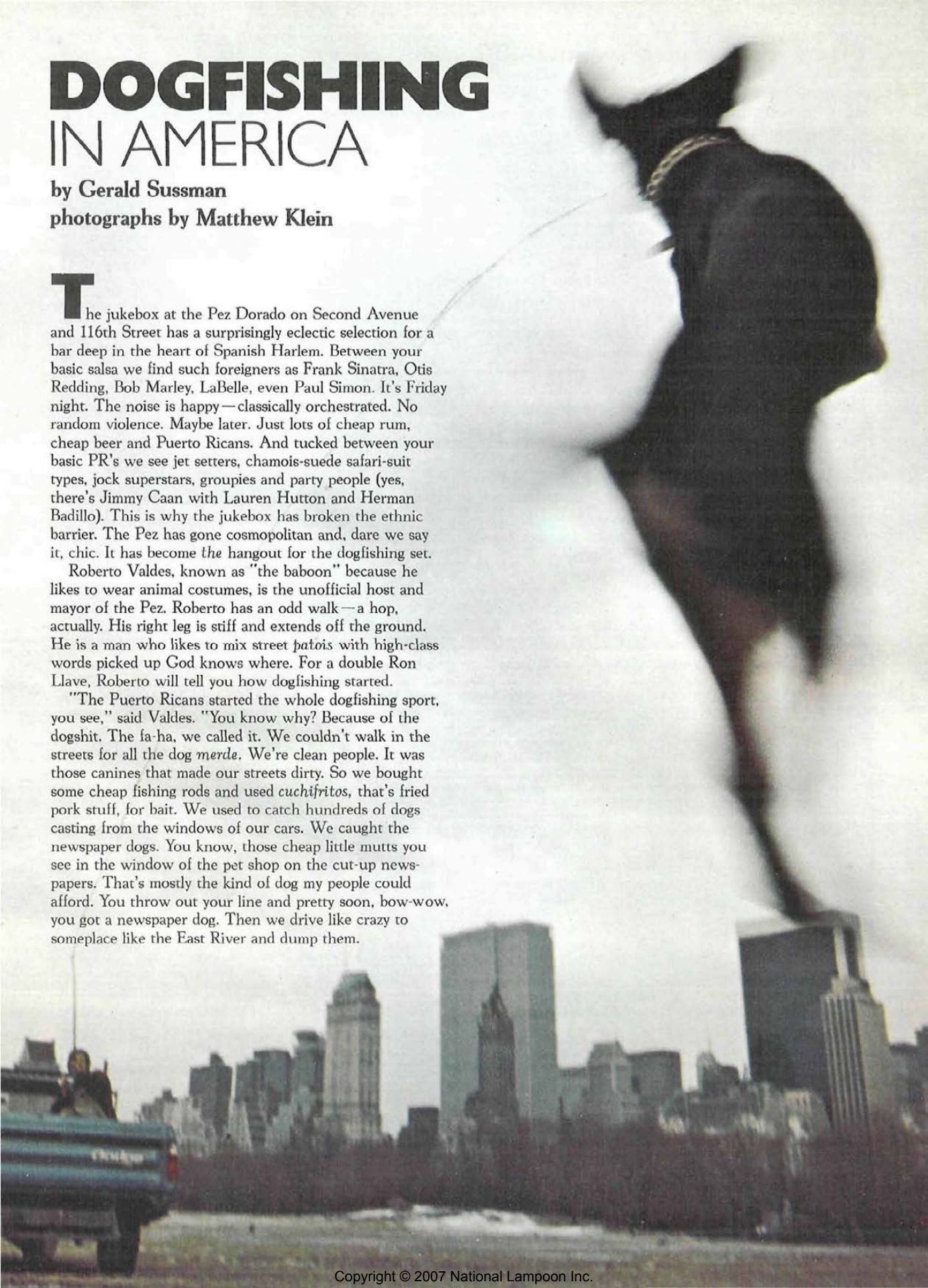

"One night I am with my friend Willie Mofongo and we are cruising up Third Avenue and we spot a real funny-looking mutt tied to a parking meter. I throw out my line and the little bitch grabs the bait. Seems like it wasn't tied up right so it sprang loose. It put up a nice fight for a tiny dog, but we finally caught it. Very cute dog. Looked like it took tiny shits, cute ones, you know. But you can step on a tiny turd even easier than a big one. It's the tiny ones you got to watch out for, *n'est-ce pas*?"

"Well, we really did a dumb thing by catching that little dog. Turned out it belonged to a very dark Cuban by the name of Reuben Olivar, or Angel Eyes, as he was called. Angel Eyes was second in command of the drug business in Spanish Harlem, plus he dipped into other highly illegal activities. We had snared and dumped his favorite possession, a very fancy kind of dog, a King Charles spaniel named La Paloma, after his favorite song.

"Angel Eyes found Willie and me soon enough. He looked like the actor Jack Palance, only darker. A very menacing chap who told us that our lives were worth less than his dead dog's fa-ha at that very moment. Thinking I had about four minutes to live, I went into a big story about how I didn't care if I died because I had already experienced the biggest thrill in my life, the battle of man against dog. I had read a little Hemingway, James Dickey, you see. I had a subscription to *Sports Illustrated*. I'm not a dumb PR. I don't read Spanish love comics in the subway. So I gave him this shit about dogfishing being the ultimate sport, with more kicks than surfing, skiing, car racing, whatever.

"Well, the son of a bitch swallowed it, dug it, you see. But he was already thinking of bigger game. He wanted to fish for German shepherds, Saint Bernards, huskies, Dobermans. Yes, Angel Eyes started the whole big game

thing. He went into the parks and fished from his chauffeur-driven Rolls-Royce! And that's how all these movie stars and jet people and millionaires got into it—through Angel. He's their drug dealer, you see. He gives them a taste of underworld chic.

"So, Willie and me were saved. He forgave us. Except he had to do one little thing in memory of his beloved Paloma. He broke my right leg so I could never set it on the ground again. That's why I hop. 'For the rest of your life you're going to pee like a dog,' he said to me. 'So you'll never forget what you did to Paloma.'"

Roberto's story is just one of the many claiming to be the origin of this remarkable sport. Ask any of a dozen Pez regulars and they'll have a swell yarn for you. They all knew the guy who started it all, just like everybody in the Dublin pubs knew James Joyce.

By two AM, cheap rum goes down as easy as good rum, and the madness of the night before the big dogfishing tournament sets in. Everyone is wasted. Little boy macho antics ensue. Someone sets Jimmy Caan on fire. Roberto is summoned to piss on him and put it out. For perverse reasons, of course. They want to see him do it doggie style.

**D**issolve from Roberto doing a long beer piss on Jimmy Caan to a big sleek Doberman doing a wee-wee on a gingko tree in Central Park. Cut to: a Dodge pickup about a half mile away. Cut to: closeup of Billy Derveen, who has been eyeing this dog through his Zeiss binos. Billy is a veteran dogfishing spotter. He sits alongside dogfishing driver-guide Orris Cooper, another old hand. Billy and Orris are from Moultrie, Georgia, where they use similar techniques fishing for wolf. They're part of the dogfishing team put together by Jack Stenreuther, a wealthy gyne-



Stenreuther accidentally bumps into a school of Pekingese and Chihuahua in his hunt for the Doberman—a distraction that could lose him the big one. "They're undersize and you have to throw them back, of course," he said. "Or you can use them for live bait if you're going for Saint Bernard."



*Après the Central Park Tournament. Stenreuther tries a little sidewalk dogfishing and scores a monster of a Great Dane.*

ologist and dogfisherman from Chicago. They've been out for six hours and have finally spotted a prize catch.

This is Stenreuther's third attempt to win the CPIDFT, the Central Park International Doberman-Fishing Tournament. The Doberman is the ultimo game dog and the Central Park affair is one of the glamour dogfishing tournaments on the circuit. There are teams entered from Mexico, Canada, Jamaica, New Zealand, plus four American groups including one headed by actor Jimmy Caan.

Stenreuther feels that Derveen's and Cooper's country smarts will fare better in the hills and dales of Central Park than the usual urban guide street smarts. He may be right. Or he may not. Stenreuther looks like a stereotype of the millionaire sportsman—and he is. A ruggedly handsome, highly skilled, dedicated man who is also a tournament caliber chess player, an ex-Olympic equestrian, a squash champion and the author of a highly regarded history of wind instruments, he is quite a fellow.

**D**erveen is studying the Doberman carefully as Cooper puts the Dodge pickup in low and drives slowly up a grassy hill which will partially hide the truck from the dog's view. Derveen looks for earmarks first. High, firm, perky ears denote a great Doberman, a strong runner, a true fighter and a possible grand prize winner. He talks to Stenreuther through a walkie-talkie. Stenreuther is stationed in the open part of the truck, ready to make his cast. "Unleashed Dobie sighted near 75th street and Central Park West. Good ears, plenty of leg," says Derveen,

making it sound almost exotic in his south Georgia drawl. Stenreuther acknowledges the message and adjusts the drag on his Pfister Special. He must make a fast decision on what kind of bait to use. Conservative dogfishermen still rely on fresh meat. Stenreuther isn't sure. "A prize Doberman is never overfed by its master," he says. "He doesn't always go for meat just because it's put in front of him."

He looks over his lures — the fake dog turd, the plastic vomit. "Good sniffing stuff, but it only fools the stupid ones," he says. There was also live bait to be considered. A big dog likes to play with a little dog or a kitten. Stenreuther had a toy Pekingese and a cute alley kitten on the truck. "With live bait, it's all in the chemistry," he says. "Will the dog be interested in fooling around with a cute little nipper? He may not be in the mood."

In the end, Stenreuther chooses a prime sirloin steak, well marbled with fat. He's hoping this big beautiful Dobie is as hungry as a bear.

**S**tenreuther does a picture book cast with his sirloin and the Dobie is all eyes and nose for it. At the same time, another piece of bait is cast toward the dog, an aluminum foil box that suddenly pops open to reveal a plate of calf liver and onions. It is a new kind of bait developed by the General Foods company that overpowers a dog with the appetizing aroma of freshly cooked meat. It is supposed to be irresistible. The Dobie now has two baits to choose from. The liver and onions belong to Jimmy Caan, who had

sighted the dog from a different vantage point. He is wearing a shit-eating grin.

Stenreuther is angry but does not lose his cool. He maneuvers his raw steak skillfully around the steaming box of liver, poking it away each time the Dobie tries to bite into it. Caan is annoyed, then frustrated. The liver gets ice cold and rubbery. The onions slither off the plate and disappear. The Dobie has had enough teasing. He goes right for Stenreuther's juicy sirloin and is hooked. Stenreuther's crew gives out their first yelp of victory. It looks like a clean strike.

The Dobie takes out about two hundred yards of Stenreuther's line when suddenly Caan leaps off his truck and sprints to the dog and attempts to wrestle him to the ground, rodeo style. It looks like Caan has gone berserk. He is well known as a fanatical competitor in sports. He simply hates to lose. Even if he has to violate the rules. He is trying to get that Dobie any which way. The Dobie is having none of him, however. The animal seems to have the strength of a runaway horse, and he is dragging both Caan and Stenreuther's line up and down the hills of the park. Stenreuther is exhilarated and concentrating totally on keeping his line at the perfect tension. He wants the Dobie, with or without Caan at the end of it.

**F**or three hours, Stenreuther stays with the Dobie and the crazy but persistent Caan—a total weight of perhaps 250 pounds. His hands are blistered and raw. Sweat pours through his flannel shirt. At exactly 7:35 in the evening, the Dobie breaks off, snapping the line, leaving a semi-conscious Caan on the ground. It is all over. Stenreuther casts a lure to Caan and reels him into the truck. He gives the actor a look of weary disgust, then sighs, shrugs his shoulders and throws him back to the ground. "Not worth

keeping," he says. "I'd sooner hold on to a poodle puppy."

Derveen and Cooper are quiet, subdued, in need of a Jack Daniels. But Stenreuther regains his good humor. "Hell, it's the fight that counts, isn't it? I still have the memories even if I don't have the dog."

## The Other Side of Dogfishing

Sammy Rodriguez is a sidewalk dogfisherman who uses a Hardy bamboo flyrod he bought by mail from London. He ties his own turds. "I do wet and dry. Real ones from a poodle I keep as a pet," he said. Rodriguez also keeps tiny pieces of garbage and other baits and lures in neatly stored mason jars. Sammy looks like he stepped out of an Abercrombie & Fitch window display, complete with waders, fishing vest, wicker creel and a corncob pipe. "I don't smoke, but it looks so fine to dogfish with a pipe in your mouth," he said. "I saw a picture on a calendar once of a trout fisherman smoking a pipe while landing a big one. I wanted to look just like him."

Sammy is a member of an elite group of dogfishermen who shun the big game park stuff and never use trucks or cars. They prefer extremely light flyrod equipment and fish right on the street. Sammy uses parked cars as a cover or "blind" and will cast his turd or perhaps an exquisitely made dry or wet cockroach into a spot where he thinks a stray dog will show up. He only fishes for strays, the wild, lost mongrels of New York City who roam the streets looking for food in the manner of a school of trout swimming in a stream. Sammy wouldn't dream of wresting a dog from its owner.

**C**atching a stray is the only pure form of dogfishing, as far as I'm concerned," said Sammy. "It's you against the dog, one on one—with no unfair advantages—no trucks or cars to help you, no guides. Besides, I always throw the dogs back. Only time I keep one is when I'm really hungry. Then I like to panfry the dog on the spot. I skin it, dip it in flour, salt and pepper and fry it up in butter. I've got this little barbecue pit I dug near the river, under the West Side Highway. My buddies and I have a dog fry down there sometimes. Next year when I get a little extra money, I'm going to buy a tent and a sleeping bag and we're going to camp out so we can get a real early start in the morning. That's the best time to fish for the real good strays, the dogs that roam around wild."

**R**oberto Valdes thinks Sammy Rodriguez is a *putz*, which is not a Spanish word. It is a Yiddish word for prick, a word he no doubt picked up in the garment center where he toils. Who is to say who is the real purist? Even Valdes admits that the exciting part of dogfishing was not the catch, but the intricacies of maneuvering the dog into your car amidst heavy traffic, pedestrians, police cars, fire engines, taxicabs and other mysterious urban impedimenta. "Sammy's dogfishing is too faggy. And I can't afford that big game shit," said Valdes. "But try snaring a tricky little fox terrier on 125th Street and Lenox Avenue on a Saturday night. That's dogfishing." It's all dogfishing, Roberto. That's what makes it the best fucking sport in America.



With New York City's hopeless financial problems, there is no money in the budget to hire a staff of dogfishing wardens. And so rooftop poachers have an easy time of it. All they need is a dropline, a Colonel Sanders chicken bone and a bottle of Wild Irish Rose to keep them company.

# Dogfishing, Compleat

Dogfishing can be done with just your basic equipment—a rod and reel and some bait. Even a dropline, if that's your game. But somehow it's much more fun dressing up a bit for the sport. It's a bit pretentious, but it makes you feel good to wear a pair of hockey goalie's gloves when you're handling an angry dog. Or a goalie's mask if the dog attacks you before you net him. And a big heavy-duty ocean spinning reel gives you a nice secure

feeling when you're battling a Doberman or a huskie. It's not that you can't catch them on a twenty-dollar reel. It just won't feel the same. Get the best stuff you can afford. Cheap stuff always costs more in the long run. Be an equipment snob. Especially if you're going for the big game dogs. Don't skimp on the proper protection. Remember: the catch isn't over until that dog is thoroughly subdued on your truck.



*Jack Stenreuther is ready to subdue an angry Doberman in his complete dog silencing outfit. His face is completely protected by an Acme goalie mask. For handling an uncooperative dog before the kill, he wears hockey gloves by MacPherson and Smith. His nylon rubberized waders by Leach Brothers are bloodproof.*



*The essential tool in dog skinning is an extremely sharp knife. Unlike gourmet cooks, there is no argument here over carbon vs. stainless steel blades. Only the finest carbon steel knives kept at a haircutting edge by a professional sharpener can do the trick. Jack's knife by G. Herschel of Solingen, Germany.*

*A beautifully skinned Schnauzer ready for spit-roasting. Stenreuther's recipe: marinate your Schnauzer in a mixture of oil, vinegar, soy sauce, garlic, chili powder and cloves for two days. Then baste it with the marinade as you spit-roast it for three hours. Serve it with rice or potatoes; a green salad and a big Bordeaux such as a Calon Segur or a Cheval Blanc.*

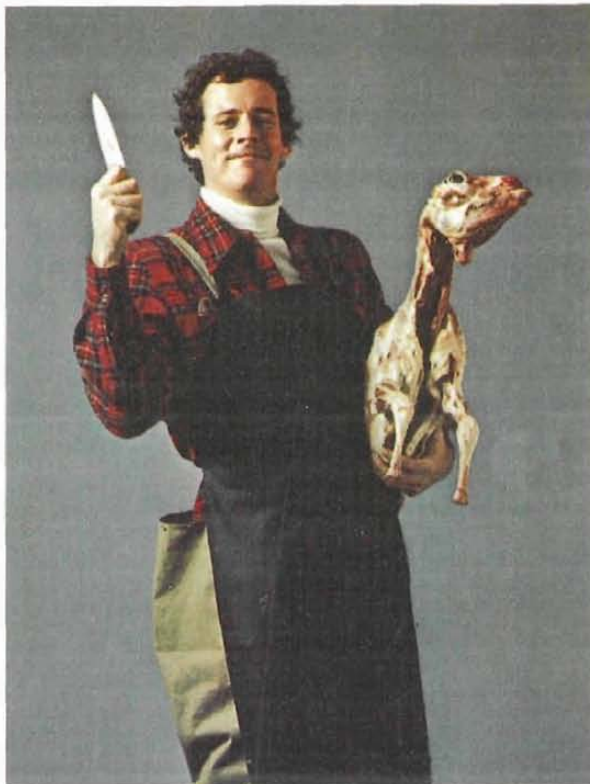

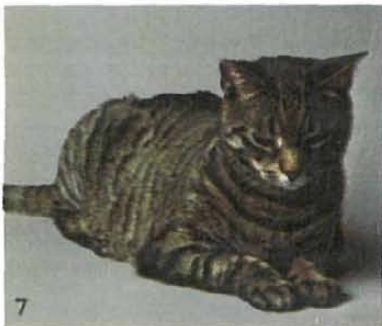

1. New York Times. Good for the larger game. Use tabloids for medium size dogs; People, Oui, other slim magazines for small dogs.
2. Fake turd also effective for dogs mentioned above and will work with small and medium size Labrador retrievers and Airedales as well. Both lures by Bliddon.
3. Stuffed toy by Stenleitz. Appeals to playful dogs, especially mongrels.
4. Basic black postman's shoe complete with white sock. An old favorite that is still used in small towns. Shoe by Moblee, sock by Diamond Brothers.
5. The old reliable dog biscuit still works. A good steady lure for suburbs and shopping centers.
6. Garbage can be used as bait and also goes very well when attached to an artificial lure to create authentic smells.
7. Kitten. Named Rollo, out of Cleopatra, sired by McGinty. Used for live bait or as a dog tease.
8. The "hot lunch" fake vomit in super-realistic plastic. Ideal for terriers, dachshunds, cocker spaniels.
9. Snub-nosed .38 revolver handles vicious types. Official "Clincher" softball bat will subdue most small and medium size dogs. Heavy duty hypodermic by Meditronics is perfect for instant tranquilizing. Whistle by Zemco works wonders, can be heard by dogs from miles away.



# SILVER JOCK

APRIL  
ONLY 60¢

THE DEMI-DECADENT SPORTS CELEB MAGAZINE

Roger Staubach's  
Odor Problem:  
Will it ever go away?

The Trick Shot that  
Nearly Killed Pete Maravich  
It happened at the New York Hilton,  
not on the basketball court!

O.J. Bankrupt?  
A close look at his Buffalo bills

**Richie Allen:**  
*"I'm George Allen's son  
and I can prove it!"*

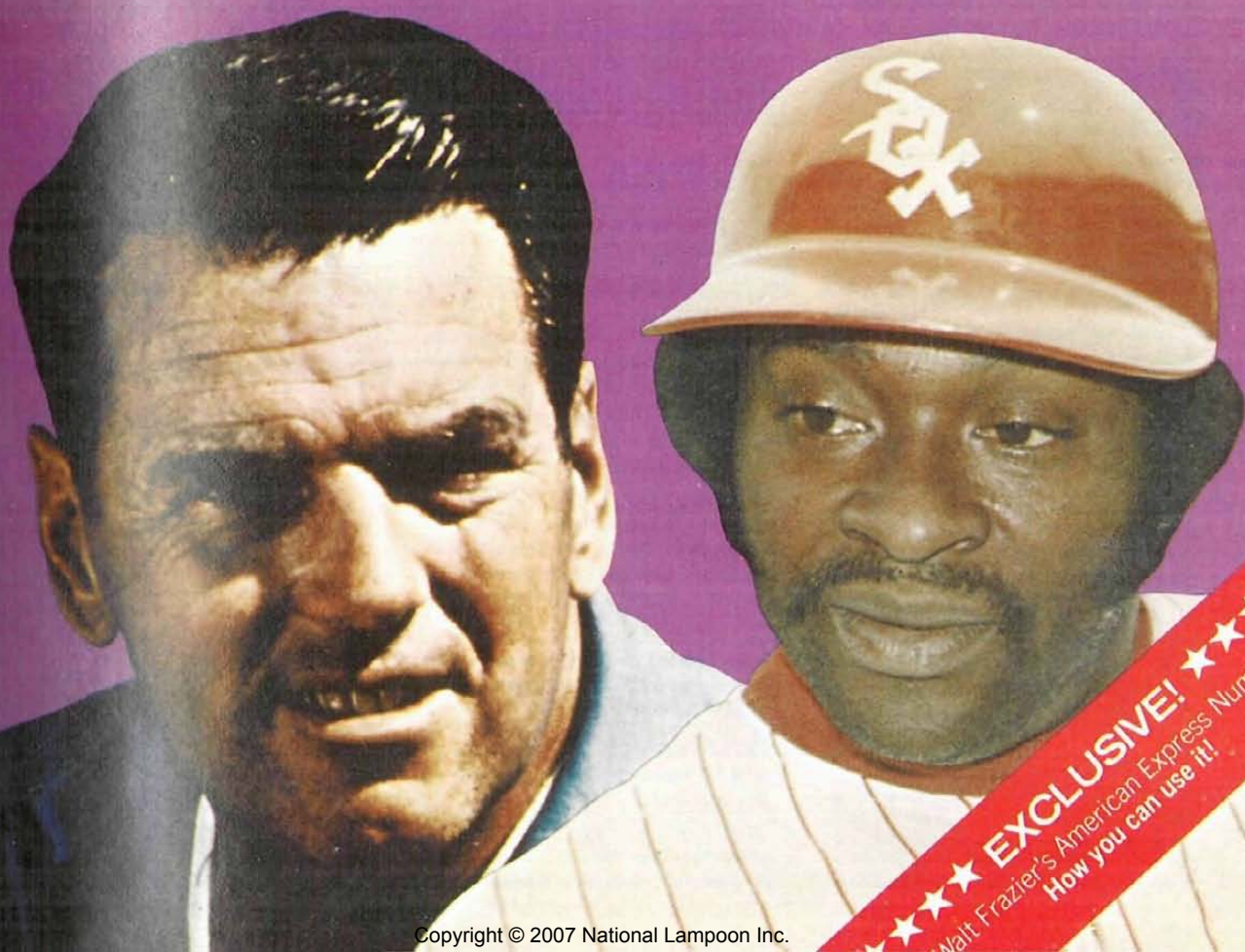

An interview with Olympic sprinter Kathi Karen of Modesto, California



*"Then I gained 10 inches on my bustline in just 6 months and I was winning everything in sight, thanks to my Milk Eden Developer."*

**Q.** "10 inches in 6 months is a remarkable gain. Kathi, why do you think your bustline grew so rapidly?"

**A.** "I don't know. One minute I was flat-chested; 6 months later I've got this huge pair. It's almost frightening. But I'm not complaining. I'm hitting that tape 20 to 30 inches faster, if you count my big stretch at the finish."

A lot of Milk Eden Developers have been sold these days to track stars who want a fuller, shapelier bustline. Though a big bustline can't substitute for God-given speed and ability, it can be invaluable when you're neck and neck at the finish line and every inch counts.

**Q.** "Kathi, did you mind the slight bit of weight you gained when you used the Milk Eden Developer?"

**A.** "No way. The main thing was the expansion of my bustline. You see, most of us sprinters are pretty evenly matched, so it's just a matter of inches on who hits the tape first. Besides, I like to wear loose, baggy shorts for running, so the extra weight I gained around my tummy was easily hidden."

The Milk Eden Developer is not an artificial vibrator or a weird kind of ointment. It is an ancient, time-tested method using millions of microscopic organic proteins that go directly into your body and through a completely natural process, create a fantastically large, shapely bust.

**Q.** "Kathi, how did you feel while the Milk Eden Developer was taking effect?"

**A.** "Wonderful. Never felt better in my life. I had this warm, rosy glow. I felt

**"Being flat-chested was costing me all the big races."**



*very content. I could almost see my bustline growing. It not only helped my sprinting, but made me feel more feminine, more womanly. Also, people would help me carry heavy packages and give me their seats on the bus. It was a very special feeling."*

The Milk Eden Developer is easy to use in the privacy of your own home. The Developer comes to you in a plain brown uniform and develops you as many times as you need until you notice a change in your bustline. Unless you have a medical problem, we guarantee that the Milk Eden Developer will work or your money will be refunded.

**Q.** "Kathi, would you recommend the Milk Eden Developer to other track stars?"

**A.** "Well, to be honest, it's so darn good I'd hate to see my rivals use it, too. But I have to say yes. I think every sprinter, every female runner in any distance should use the Milk Eden Developer, because so many races depend on a

*photo finish. You need every inch you can get. The only problem is, you have to take about four or five months off until your tummy gets taken care of. But, of course, you can go right back to active competition, can't you?"*

**Q.** "Of course. As a matter of fact, we recommend that you engage in active competition while you have that slight weight gain around your tummy. Chances are you'll drop that little extra weight in no time."

Kathi Karen and thousands of female athletes are thrilled and delighted with their Milk Eden Developers. They feel prettier, happier, and more self-confident, not only because they have those precious extra 10 inches, but they also look more feminine, more womanly when they win.

The Milk Eden Developer costs only \$99.95 complete. The Developer comes to your home as many times as needed, until the exclusive Developing Process takes effect. Your \$99.95 covers everything. You also receive a complete set of illustrated instructions in the Milk Eden Developing Technique . . . and for only \$19.95 more, you can also get complete medical coverage if you decide to KEEP YOUR NEW BUSTLINE FOR THE FULL NINE MONTHS!

## Milk Eden

P.O. Box 5478 Dept P-2  
Sherman Oaks, CA 91376

Please RUSH me my Milk Eden Bustline Developer. I understand that my Developer can be used as often as needed and there will be nothing else to buy. If I do not see a startling change in my bustline within six months, I can return my Milk Eden Developer and receive my money back.

I enclose \$99.95, plus \$5.00 for initial cab fare. All other transportation costs will be paid by Milk Eden.

Cash  Check  Money Order

(Milk Eden Developers come in plain brown raincoats)

Name \_\_\_\_\_

Address \_\_\_\_\_

City \_\_\_\_\_

State \_\_\_\_\_ Zip \_\_\_\_\_

by Y.A. Tattle

**BILL WALTON**, controversial center of the Portland Trail Blazers, is not a veggie-tarian by choice. Doctors discovered that eating meat makes him crazy drunk. **SPEAKING OF BEAN POLES...** did you know that many basketball players have detachable limbs? Those knee braces they wear are actually holding up artificial legs. **TOM LANDRY**, brilliant coach of the Dallas Cowboys, killed the people at the Concord Hotel, classiest hostelry in New York's famed Borscht Belt. Tom did 45 minutes of shpritzzy standup comedy, punctuated with special country and western material written for him by Barry White.

**WHERE ARE THEY NOW AND WHO GIVES A SHIT DEPARTMENT...** **ROCKY GRAZIANO**, former middleweight champ turned novelty actor and vulgarian is now the caretaker of a small, shabby synagogue on Chicago's South Side. **SPEAKING OF HEBREWS...** Rod "The Jew" Carew just chalked up another convert... Muhammad Ali. Ali joins the all-star lineup of Rod's Fellowship of Jewish Athletes, a roster that includes Derek Sanderson, Jethro Pugh, Terry Bradshaw, Roberto Duran, and Eddie Arcaro.

**KIPPY KEINO**, the Kenya Komet, will do your income taxes for you in his spare time (he's usually finished running in about four minutes, ha-ha!). Kip is a whiz at math and charges very reasonable rates.

**WHAT DO THEY DO IN THE LOCKER ROOM BETWEEN PERIODS?** The New York Rangers plunk themselves down on big leather club chairs, drink vintage port, eat filberts, and talk about horses and first editions--that's what they do.

**PERSONAL FOULS...** **RED HOLZMAN**, coach of the once-great New York Knicks, plans to divorce Selma, his wife of 30 years, to marry a Nigerian chippy who works for the U.N. Be careful, Red. She'll give you a heart attack.

**PAUL BROWN**, stop your secret drinking. You'll kill yourself in six months or less if you keep it up. We know how disappointed you are about your Cincy Bengals' failing to reach the Super Bowl, but it's no reason to quaff yourself into an early grave. Where's that legendary self-discipline and pride we've head so much about?

**SILVER JOCK'S AWARD OF THE MINUTE...** This minute it goes to **GEORGE FOREMAN**, former Heavy Champ, who has contracted to box a 400-year old Sequoia. The Foreman-Sequoia match is scheduled to go 15 months. Early odds quote the Sequoia the favorite by 7-5.

**SNEAKY PREVIEW!!!** Famed journalist Judy Klemesrud interviews **WILT CHAMBERLAIN'S COCK** in next month's *Silver Jock*. Yes, sports fans... Wilt has trained his choco-pop to talk. And talk it does, in real nig-nog slang! Wilt is one of those guys who can do anything when he sets his mind to it. □

## PEDOSCOPE

### Athlete's Foot Readings

by  
**Alma Drebing**

**Bill  
Walton**



Before I analyze Bill Walton's feet, I must warn him that they are far too small for a big man. His shoe size is only 4½. This is why he gets injured so much. Evidently he hides his tiny feet in size 14 sneakers (the usual size of a seven footer), filling them out with newspapers and cotton balls. His feet are simply too small to support his great size and weight, and he tends to wobble a lot and break his bones very easily. I would strongly recommend a foot enlargement operation, a bone graft, at the end of the season.

The absence of any clearly defined sole lines signifies a need for subterfuge and bland cover-ups, as if the vegetables he eats are really meats in disguise. Can he be hiding baby lamb chops in those large carrots? Perhaps in a few years he will develop more character in his feet so that I can offer a more detailed analysis.

**Jimmy  
Connors**



It looks as if Jimmy Connors has two left feet because of the extra-long slope of the heel. Or perhaps it's the angle of the foot in the photograph. Pictures can be deceptive. But Jimmy is left-handed, we know that for sure. And it shows in his feet. His sole is all swirl lines, semicircular in shape, indicating a large brain that is still almost untapped and a small but sly sense of humor in his own special field.

The outer foot is surprisingly dark, which leads to the obvious question: is Connors actually of the Afro-American persuasion? The rest of his body is white (is it makeup?), but this is the first time we've seen his bare feet. The bone configuration and veining is definitely Negroid. The peculiar round shape of the big toe indicates a possible talent for jazz tap or eccentric dancing, which he probably does at private parties. The curve of the bone above the big toe indicates an ability to sing, and we should expect him to begin a new career in show business very soon. Jimmy Connors is a closet Negro.

**Muhammad  
Ali**



Muhammad Ali's sole is extraordinary in the amount of lines it holds. Virtually all of the sole up to the heel line is covered in a maze of intersecting lines, signifying the many facets and levels of this great star.

How to explain this endlessly complex man? The beautifully curved lines near the little toes tell us that he is a fanciful sort, a mock poet. But the curl of the littlest toe also says that he is deadly serious and terribly shy (note how the toe almost withdraws into the foot). Below the toe line there is an area around the arch that shows a finely bunched group of lines, seemingly connected but in fact separated by tiny fractions of an inch. Each line is slightly different in length and shape. Here we see some of the layers of the Ali persona—the bravado that hides the shyness, which in turn hides even greater bravado, which in turn hides shyness, and so on.

The total picture is of a man who is tough, tender, aggressive, shy, brave, prudent, confident, insecure, virile, impotent, articulate, and tongue-tied. Is this the real Ali? Again, it is difficult to say. If we could only read between the toes we might get a more accurate answer. As it stands, this is all Ali wishes to show us at the moment. □

SILVEREXCLUSIVE!!!

# Joe Namath Will Quit Football and Become a Gangster!

(Say it ain't so, Joe!)

**Y**es, another exclusive Joe Namath story. Don't turn the page. Don't yawn. Please. This one is true because Joe told us to our faces. He wants to become a big-time thug, a hoodlum, a chic and glamorous outlaw person.

**NAMATH:** *I've lost the use of both legs. My arm is shot. My body takes a terrible beating every Sunday. Forget the cheap shots. I'm taking too many good shots. I can't remember the signals. I can't think of a good play anymore. I can't even fool my Aunt Harriet. If you got any good plays, tell me. Got any good trick plays I can use?*

**S.J.:** Joe, never mind the trick plays. You don't have to prove that you're the best. We know what you can do on a football field. That's over. That's ancient history. It's here and now we're concerned with. Is it true about your new career aspirations?

**NAMATH:** *True. I'm through as an athlete, so where do I go from here? My contract with Brut doesn't really amount to much money. What was it? A couple of million over five years? After taxes and agents' fees and whatnot, it comes out to a lousy \$76,500 a year. That's my hat check tip money. I lose that much on one dog race. Forget it. I need ten times that amount to sustain my inimitable lifestyle and glamorous image.*

**SJ:** And this is why you're entering the field of organized crime?

**NAMATH:** *Extuckingactly. I need the money and the bigtime hoods need me to improve their image. Put me in a custom-tailored tux, with a black homburg, English patent leather pumps, shirts by Turnbull and Asser, etc., etc., and I look like the most lovable, roguishly charming gangster in the business. I mean, I'm not into the rough stuff...heroin, loan sharking, hit men—I'm going into night club ownership, a piece of a gambling casino, maybe some class escort service, at most a little soft drug traffic. But no violence, no penny ante stuff.* (continued on page 108)



## WHOSE BABY IS BILLIE JEAN KING CARRYING?

“Not mine,”  
says  
Billie Jean

Is she or isn't she? *Silver Jock* says yes. We say Billie is a little pregnant, which is the same as big pregnant. You can't fool us, Billie J. You're preppers.

**BILLIE JEAN:** Why don't you go whack a few Wilsons and leave me alone? I said I'm not pregnant and I mean it. Now go away and work on your backhand.

**SILVER JOCK:** Then how do you explain those visits to obstetrician Milton J. Schwenkman?

**BILLIE JEAN:** Dr. Schwenkman also happens to be a practicing CPA and does all my nonathletic tax affairs. Will you please go away now? Why don't you chase a few lobs?

**SILVER JOCK:** Billie J., we think you're trying to give us the big overhead. We think you're fibbing. It's been told around the locker room grapevine that you've missed two straight periods, mensa-wise. We've been told that you haven't touched a Tampon in almost 90 days, true or false?

**BILLIE JEAN:** There's a certain amount of viciousness behind those allegations. Also a lot of ignorance as to how a woman's body works. You can skip many a period without being preggy and you darn well know it. So stop spreading silly rumors and volley off.

**SILVER JOCK:** Billie...the bottom line is what we see. What we see is

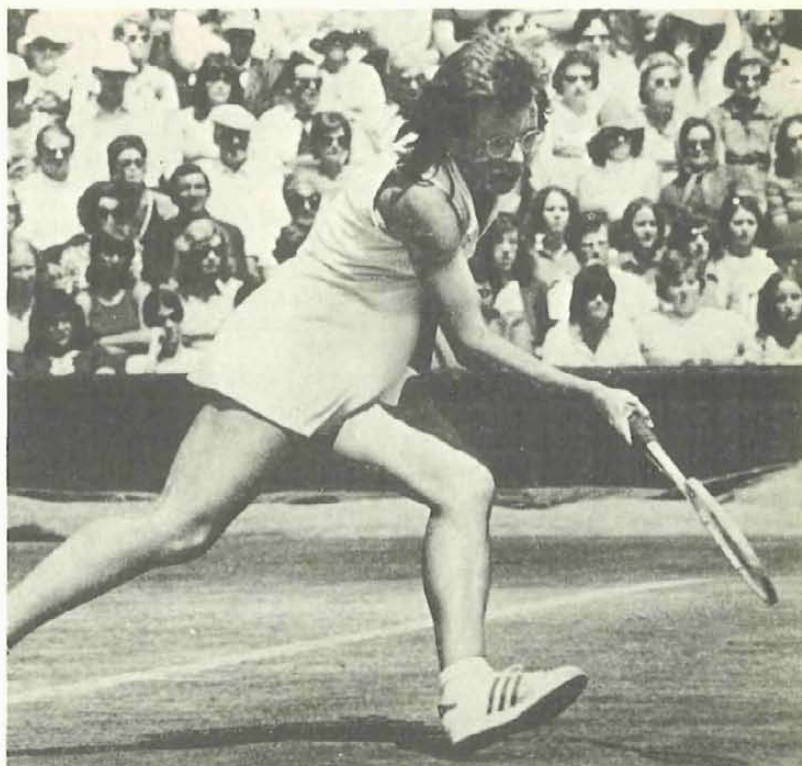

a tum-tum of more than normal proportions, especially for a trim bod like yours. How do you explain the bulge, Bill? How?

**BILLIE JEAN:** I'm not playing as much as I used to and I've allowed myself a few eating indulgences. Specifically, those shore dinners at Maggio's. Lobster in drawn butter, corn on the cob, garlic bread, washed down with a couple or three Miller High Lifes. Is that bad? What's bad about that? I've worked hard all my life. I've won every title a woman could win. I shellacked Mr. Riggs and I've copped Wimbledon more times than any lady in the game. I've done it all. Now I want to enjoy myself. I want to eat like a baby bull.

**SILVER JOCK:** Not a bad cover story, Billie. But it won't wash. That's not a food tum-tum, that's a

preggy tum-tum. Now, 'fess up. Whose babe is it? If you don't 'fess up and tell us, we'll simply start the rumor mill humming. We'll dig up every possible name. We'll scrape the bottom, if we have to. And we ignore lawsuits. We're positively bulletproof. We're slime-bars. We just don't give a tinker's forehand about your privacy or your dignity. We've got two million readers who want to know!

**BILLIE JEAN:** Oh, God. How did I ever get into this? I can't believe it. I give up. O.K. I give up. The baby belongs to...to...Cesar Chavez! O.K.? Are you satisfied now? Cesar Chavez! Cesar Chavez! Cesar Chavez! Pancho was teaching him to play tennis. I met him at Pancho's clinic. We fell in love. We're going to have the baby no matter what anyone

(continued on page 54)

# LIZA MINELLI'S FIRST GANG-BANG!!!

*"Clara Bow did it with the USC football team, a bunch of amateurs. I wanted the best, so I took on the world champion Pittsburgh Steelers," said a tired but happy Liza*

No one will ever accuse Liza Minelli of being a party pooper. When Liza throws one, she goes all the way. For appetizers, she had lots of her oldest and dearest friends: Marisa Berenson, Tony and Berry, the Halston gang, the Warhol mob, the Fosse posse, and other New York chic-o-rama lovelies. For the main course, she went strictly H-wood, with everyone from Chill Wills to Tatum O'Neal. Running true to form (zaftig but still sexy as hell), she nixed the dessert guests, which normally would have been a grab bag of surprises (Joe DiMaggio, Maureen Dean, Lou Reed, William "Wild Bill" Weaver). Instead, she gorged herself on dessert all by herself—no less than *forty*, count them, *forty* big, bony Tootsie Rolls and a few vanilla flavored jobbies, in the wildest GB in town!

"Now I know why they're the Super Bowl champions," said Liza. "They're a rough, tough, cocky bunch (pun intended, of course). They play hard and they play to win."



**Mel Blount**

*"Without realizing it, Mel cracked me across the neck with his forearm and knocked me unconscious for an hour. He calls it his 'cheap shot' and does it automatically to everyone he meets. When I recovered, he more than made up for it. Oh, God in heaven, there was nothing cheap about Mel!"*

**Terry Bradshaw**  
*"Don't let Terry's ol' country boy look fool you. He's very city slicker once he gets his confidence. And what an arm!"*



**Franco Harris**  
*"Franco is exactly what you would expect from a half-Italian, half-blackamoor—very romantic—he mumbled all kinds of lovely compliments (at least I think they were compliments), but also a very bad dude!"*



**Mean Joe Greene**  
*"In most cases, men like Mean (that's his real first name) are just gentle giants, big Teddy Bears. But not this one. Thank goodness I'm big enough for that entire front four and a Harley Davidson combined!"*

**Lynn Swann**  
*"Doesn't that beautiful name say everything? A beautiful, beautiful man. But why did he have to dive at me? He treated me like a football."*



**Jack Ham  
Jack Lambert  
Andy Russell**

*"Jack, Jack, and Andy insisted on gang tackling me... plugging the hole, they called it. Amazing how football is similar to sex, rather than war."*



A born trouper, Liza flashes her last dazzling smile before being helped to Cedars of Lebanon for a well-deserved rest after the gala GB.

# World Famous Soccer Player Pél  Answers the Question Why He's No Longer Famous

"Last year's player of the year is this year's water boy," said Walter Pater. And a truer word was never spoken, at least when it comes to P  . Last year, nobody bigger. This year, phfft! Last year, soccer's great star woke up half the world to the fact there was such a game. This year—dropped from the *Guinness Book of World Records*, the Soccer Hall of Fame, and *Who's Who in Sports*. The same people who hailed him last year, this year look dumb when his name is mentioned. But P   likes it that way. When *Silver Jock* interviewed him in his palatial oubliette in the Brazilian rain forest, he had this to say:

"I vanished. My profile is low. I'm no longer famous, and anyone who says otherwise is wrong, although I will forgive him. My importance has declined to the point where I might as well be the owner of some corner, or even midblock, candy store. When I enter first class restaurants, maitre d's do not usher me to ringside tables or patrons rise en masse to tear limb from limb that one of them who has been intrepid enough to obtain my autograph. No. They know who I am, of course, but they disregard it. There is no thrill. They look right through me.

"I continued to go to first class restaurants because my enormous salary has continued to be paid to me, even though nobody ever heard of the Cosmos Soccer Team after a certain point last year, and may never hear of them again, since they vanished with me.

"But I have vanished several times in my life. Yes. One time in 1974 when I was playing for the Santos Team in Brazil, I vanished. Only a huge increase in salary caused me to become visible again. After which I quickly vanished once more. My myth faded. Ordinarity. Nonentityhood. Then my myth gained solidity once again as Warner's started paying me 20 million cruzeros for three and half months' ball playing. When it was over, I began to dim. Flicker. Go out. So I began to advertise bicycles, refrigerators, and television sets. Soon you could see me once again. My form filled in. Light shone around me. My name was over the title. But soon I started to go out. Ebbing. Withering. Evaporating. So I began to advertise sneakers, undershirts, coffee, and banks. I began to appear once again. 'There he is,' people would say, and they weren't lying. Now I seem to be fading once again. Watch me. Do you see my arm? No, you don't. It's going. There goes my elbow. My shoulder. Good-bye, shoulder, arm. Worth six million to make it come back, two



hundred thousand a finger. Look, there goes my left foot. Funny, isn't it? Four million and it will reconstitute itself. Little tic it has. I am a good Catholic, though. My blood pressure is a steady 54. But you'll have to take my word for that because there's nothing to wrap the cardiograph around. My buttock is going, see, isn't that cute? My passport is in order and were my buttock not expiring, I would show you how I have all my vaccinations for reconstitution in any country you can name. Twelve million and my myth is yours.

"Would you like to see me reappear? Are you a rich man? How much do you have in your wallet? Do you see this one hair growing out of my car—catch it before I vanish entirely! All right, now I've gone. You can't see me at all—right? Very well, put the contents of your wallet on the table, and look very carefully in the general direction you recall my ear to have been. That's it. Look carefully. It'll reappear. Just that hair. Keep your hands away from the table. Good. My, these bills are fresh. Now, is it reappearing? Can you

(continued on page 78) 7

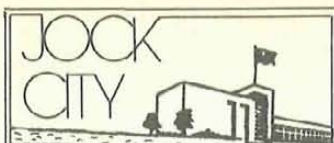

*The Condominiums of the Stars*  
**OVER 30 AND OVER THE HILL?**  
 Suffering from chronic knee injuries, sore arms, weight problems? Why risk the humiliation of being fired and replaced by a younger stud when you can retire to Jock City and live off your long term contract? Or why risk the humiliation of hanging on in the minor leagues or those fly-by-night expansion teams? Live the easy athlete's life of Jock City, the retirement village for has-beens and the permanently injured. Play it out easy and slow at "JC," where you can participate in every sport in regulation size stadiums and arenas, complete with capacity audiences. Jock City also offers you jock bars and restaurants to hang out in, complete with groupies and "foxy ladies." Endorsement contracts from local merchants are also available. Jock City offers you the full jock lifestyle without the rigors of competition. One room suites start at \$79,990. Write to:  
**JOCK CITY, Box 4, Miami Beach, Fla.**

**Another Silver Jock Exclusive!**

# "I LOVED BEING KIDNAPPED!"

says Most Valuable Player  
**Pete Rose!**

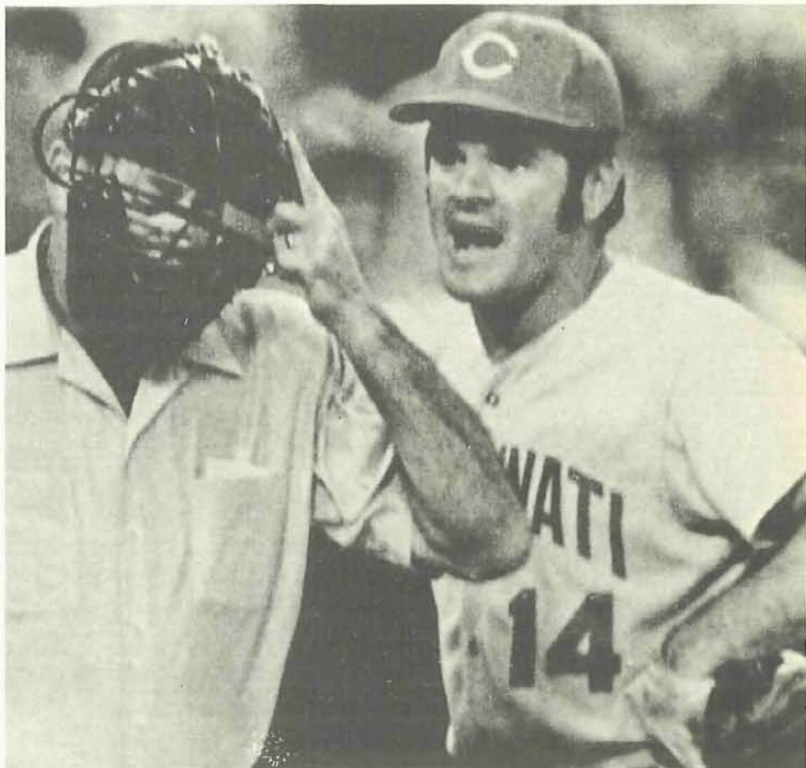

**100 GREATEST PEP TALKS !!**

Tapes you can play to your team before the game—any game—any sport! Makes you a winning coach! After all, why blow the big ones? Just insert your team's name in these rousing orations—and go on to sweep the field. Send for illustrated booklet to:

**Doom on the Playing Field**  
 Heartbreak House  
 Sober Sides, N.M.

**DROP THE SOAP**

Tournament Rules and Regulation Handbook

You've always wondered how to play? You never got beyond an amateur standing? Now become the authority in your shower room set, or develop your skills to become a master. Join the international circuit! Compete for big prizes! Here the world's five-time Grand Master sets forth the rules for correct and ethical play, with full diagrams and game plans. He also gives his own secret tips for winning competition and calculating the "odds." For particulars, send to: **Drop the Soap Rules, Darius Milhaud Lane, Finders Keepers, TX.**

**Personalized Jocks**

Delight your teammates! Jocks embroidered in silk with (a) two hearts with any initials you want; (b) eye pine four u; (c) I'm a big ball carrier; (d) Hi, big boy! (e) Mother; and (f) our stunning peekaboo jock with a hole you can see through. Send for brochure to Dumbkopf Products, Haveaflutter, PA.

## His brush with the underworld...now told for the first time in his own words!

*The rash of kidnapping which swept Italy of its heirs and France of its thoroughbred horses was capped this past January by the snatching of Pete Rose, funny-looking yappy wowser third baseman for the Cincinnati Reds. Rose was returned for a mind boggling ransom, his bangs unshorn, his pep and volubility undiminished. In this exclusive interview with Silver Jock, the high-gear baseball star of the Reds displays his —*

"Shut up! Locked me in a closet, but I talked the whole time, right through the door. Talked and talked and talked and talked. Then they gagged me, but I talked right through the gag, talked and talked and talked and talked. Sitting around the kitchen table playing whist,

the game of choice for kidnapppers, as they waited for communication from the outside world, they kept hearing me mumble through the closet door, mumble, mumble, mumble, mumble. Nothing they could do about it. Drove them crazy, not knowing what I was saying."

"What were you saying?"

"Clam up, buster. Let me put it my own way. Cheese, a guy can't get a word in edgewise around here before some drooper tries to put a whole lot of stuff in his mouth he didn't even say. So, you be sure you cut that part, see, where it's not me talking. 'Cause I didn't say that part. I didn't say it, and I don't like it. Get it? Okay. Now. As I was saying. Before your last pathetic attempt to bunt. Was that I was giving them a pep talk through the closet door, rallying up a little team spirit, a little game juice, a little groupspark—neetapicky-eatapicky doo-da-dee—ya know what I mean. That is to say, they were so doomed, so down, so dung-low, it was like a mortician's funeral in there. Ya see, kidnapppers—ya listening?—look at me



when I talk to you, keep your eyes on me, right here, on my mouth—good—kidnappers, as I was trying to say before I had to put down your back talk, are not among your social snapcracklepoppers or high morale groups. Uh-uh. They're sour, they're bitter, got the losing blues—you look as though you want to say something—don't—so, what I did was give them some up-words and peak verbal experiences, getting them high and higher. Go, team, go! That was my pitch."

"What result did it produce?"

"Earplugs. And who asked you anyhow, blabbermouth? Damn near missed the ransom call, poor slackers. I had to yell at them to take their earplugs out because the telephone was ringing, get it? Christ, you're slow. But when they opened the door and let me out so I could talk to manager Sparky Anderson, I said no. I wouldn't talk to him, I wouldn't talk and talk and talk and talk. I wouldn't."

"Everyone thought you must be dead. The whole world turned their radios off for thirty seconds."

"Don't interrupt, sissy. Even with praise. I hung up, and hung up and hung up and hung up. Boy, did I hang up. Then I rounded on them. I gave them a dressing down. Zapadedoo-fee eggs-foo-yong! Those dopes, those creeps, those poor dumb chumps—they were asking too little ransom money. Half a mill was all! For me! Cheapskates! Small-timers! Bush leaguers! I quickly wrote up a contract for them for \$3,000 a week for five years, called back management, had the money deposited in a Swiss bank, and jogged home, feeling that I had outperformed myself 110 percent once again!"

"That was your reward?"

"Hey, who's telling this story, anyway? Yeah, that was my reward. You have mean eyes, you know that? My reward and my ransom. Since I scooped up 10 percent commission for myself—wheatapickle beetapickle snow-job Sue—which I talked them into beforehand!"

"How?"

"Hold on there a minute, give me a chance, will ya? I wormed the 10 percent out of them, idiot boy, by threatening to talk them into 20 percent. Smart, hah? Clever, hah? Anyhow, they have named me Most Valuable Kidnappee of the Year. Since that time, as you know or ought to know, if you can add that far, I have been kidnapped five, count them, five times. Earned 10 percent from each one. The last three in advance of the crime itself. One of them before they even got me into their Chevy. I worked out the whole deal for 'em at a pay-phone while they lounged at the getaway car passing around Clorets. The last time, I never even saw the kidnappers. Handled the whole thing by postcard. Didn't have to leave my armchair. Don't like postcards. Don't know why. Anyhow, we don't talk to management anymore. Arrange everything with Ted Kluszewski, the batting coach. But I'm thinking to raise my ante to 15 percent for the next season because, like the man sez, (continued on page 84)

Olympic Gold Medalists Recommend

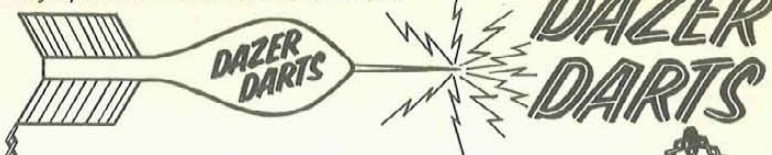

You're running in eighth place, fat, out of condition, gasping. Suddenly the man in front of you collapses to the ground, writhing in speechless agony. You whip by him, for your DAZER DART has struck again. This handy little gadget renders immobile with a "harmless" electric shock any and all opponents. One by one the remaining six contestants skid to the cinders, while you go on to win the event, chest out, eyes clear. Perfect for winning at rugby, soccer, basketball. Why intercept passes? Just zap the receiver with this easily concealed Dazer Dart, and he'll fall to the grid like a gibbering idiot. Produces extraordinary effects in swimming, tennis, ice skating, and skiing. Also yacht racing, auto racing, sports flying. You can use it anywhere—on elevators against people whose faces you just don't like, or just randomly in cocktail lounges and hotel lobbies. Lots of fun! For further data, write to Dazer Darts, Wilmington, DEL.

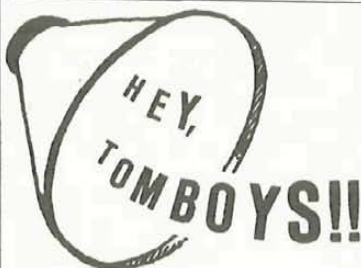

Do you prefer baseball to jump rope, football to paddle ball, boxing to tiddledywinks? Do you hate dresses, and just love cleats? Well, change that C-cup for a steel cup. Send for our Jiffy Pill, containing a rare elixir which will transform you even before puberty, and save yourself a pesky trip to Sweden. Only \$2.98 with free fun condom to try out your new equipment. Send for info to:

Valhalla Products  
14 Sheep Dip St., Bloomington, Indiana

## Coach a Team by Mail!

JOIN THIS UNIQUE SPORTSMAN'S CLUB, and improve your play-by-play post mortem techniques. Just take our test to determine your rating—Beginner, Intermediate, Advanced—choose your favorite team, and we'll match you with an opponent team coach each week. We'll put you in contact with someone on your own level or above so that you can really gain expertise in rehash and Monday morning quarterbacking. We supply you with handbooks, rosters, play sheets, too. For this wonderful self-help offer just write to:

BULLPEN PALS, POB 9002, MIAMI, FLA.

## The Gentile Athlete

A Picture Essay



Here now at long last is a picture book depicting that rare breed of man—the professional athlete who is neither Polish, Jewish, Black, Puerto Rican, or anything like that, but pure WASP. This beautiful 300-page cocktail table size volume includes every such athlete from the beginning of time to the present day—all three of them. Send to:

The Gentile Athlete  
13 Broombroom Street,  
Cad, ARK.

## Purple Piss



Weaklings, this is for you! If you're humiliated in the shower by those muscular quarterbacks with their fabulous perks and luscious lolocoeks while your meat is no bigger than a cashew, now you can get back. Just take the tiny, harmless pill of natural food coloring, stink up the urinal next to the BMOC and piss purple! He'll fall to his knees before you! Delight your friends with it, confound your enemies. Tell dad about it! Send to Purple Piss, POB 9987, Central Post Office, Chicago, Ill.

## Turn Your Living Room into a Locker Room!

Hey, bachelors! Wallpaper your studio apartment with this unique locker room paper—just like real. 'Cause it looks like an actual locker room, with some lockers open, some jimmied, some with combo locks, old T-shirts, dirty jocks, initials scratched in, empty Vitalis bottles, damp towels. A real man's world in locker green or gray paper. For sample book send to: Ballys Inc., Devastation Blvd., Wallflower, TX.

NUMBER THREE, WE'D LIKE YOU TO SHOW OUR READERS HOW YOU'D LOOK IN AN ACTUAL FOTO FUNNY, TO HELP THEM MAKE AN INFORMED CHOICE BETWEEN THE SIX OF YOU FINALISTS FOR OUR NEW MISS FOTO FUNNIES. GOT IT?



# FOTO FUNNIES



UH-HUH.



FAMILIARIZE YOURSELF WITH THE SCRIPT, NUMBER THREE. AND, CHRIS, THIS TIME I'D COOL IT WITH THE HANDS...

LET'S GO, NUMBER THREE!

A PERISCOPE.



HEY, DON'T WORRY, MAN. NO MORE FOOLING AROUND.

UH, YOU'RE SUPPOSED TO HOLD OUT YOUR BREASTS. AS IF THEY'RE A PERISCOPE.

HERR KAPITAN, BRITISH DESTROYERS! PLEASE TO LOOK THROUGH DER PERISCOPE.

WELL, NOT THE WHOLE PERISCOPE. YOU KNOW, JUST THE EYEPiece.

U R A  
M LIKE THIS? A  
W



RIGHT! AHem! NOW SAY YOUR LINE.



VAS?

OH, CHRIS!

MMP! HLMP!

CUT! CUT! JESUS CHRIST!



MLIP

AH, Goot! FIRE NUMBER FOUR AND TWO TORP — MMMPH!



OH, GOD, BABY, I'VE READ ALL YOUR STORIES AT LEAST A HUNDRED TIMES I THINK I'VE BEEN IN LOVE WITH YOU SINCE "TELEJESTER". PLEASE, PLEASE, PLEASE NUZZLE AT MY FIRM

# Valley Heights High

Cincinnati North Suburban League Champions 1973, 1974, 1975

by Beverley Jeanne Parkwright

## I. Confession by Coach Slumbach

I guess it all started when Coach Slumbach, who's the football coach and also teaches Drug Education, walked into the girls' locker room by accident again. "Oops! Wrong door!" he apologized. "Excuse me girls! What an embarrassing thing to do!..." and so on and so forth. (It always takes Coach Slumbach a long time to apologize when he walks into the girls' locker room by accident. Which he does about once a week even though the boys' locker room is practically at the other end of the school.) However, all of us in Honors Pep Gym were decent. Coach Slumbach, on the other hand, looked really icky. Honors Pep Gym is a special gym class including we cheerleaders, the Badgerettes, who wear the Badger suits at football games and do tumbling, the Baton Twirlers, and girls who can play tennis and have a B average. Everybody in it thinks Coach Slumbach is really cute, so even though all of us had gotten dressed extra quickly so we'd have more time

to discuss the theme and decorations for this year's Ice Ball winter dance next period during homeroom, we were still concerned over the way he looked worried sick. It was so sad.

"You don't look good, Mr. Slumbach," we said, "you'd better sit down or something."

Well, at first he wouldn't say what was the matter, but we told him that after all we were seniors and that if anything was wrong around the school he could talk to us about it frankly because except for the teachers and not counting the cafeteria help, we were the adults around here now.

"It's the team, girls," he admitted at last. "I can't get them to practice or learn their plays or anything. They just don't seem to have any of the old school spirit at all." Which is a terrible thing for Coach Slumbach to have to say because you should have the same kind of loyalty to your school that you have to your country, parents, or suburb. Plus the Hesserman Oldsmobile North Suburban League Championship Trophy was at stake.

If we won it this year we'd get to keep it permanently at Valley High as we would have then won it three times in a row. "They started out O.K.," continued Coach Slumbach, "but I had just gotten through the third week of triple practices when a delegation from Concerned Parents showed up to see me and said that football was too violent and so was television. Also it wasn't safe for young people to fall down so much while they were still growing." Mr. Slumbach said they said that violence causes wars and they were opposed to that, and also the recommended football players' diet called for two meals with meat in them a day and America was eating too much meat already. Plus the Concerned Parents wanted the whole North Suburban League to quit using tackling in the football games so everyone would cooperate and quit competing and they weren't going to let their sons play until this stopped. Fortunately, Coach Slumbach said these are the kind of people who have second-string football players for

*continued on page 84*

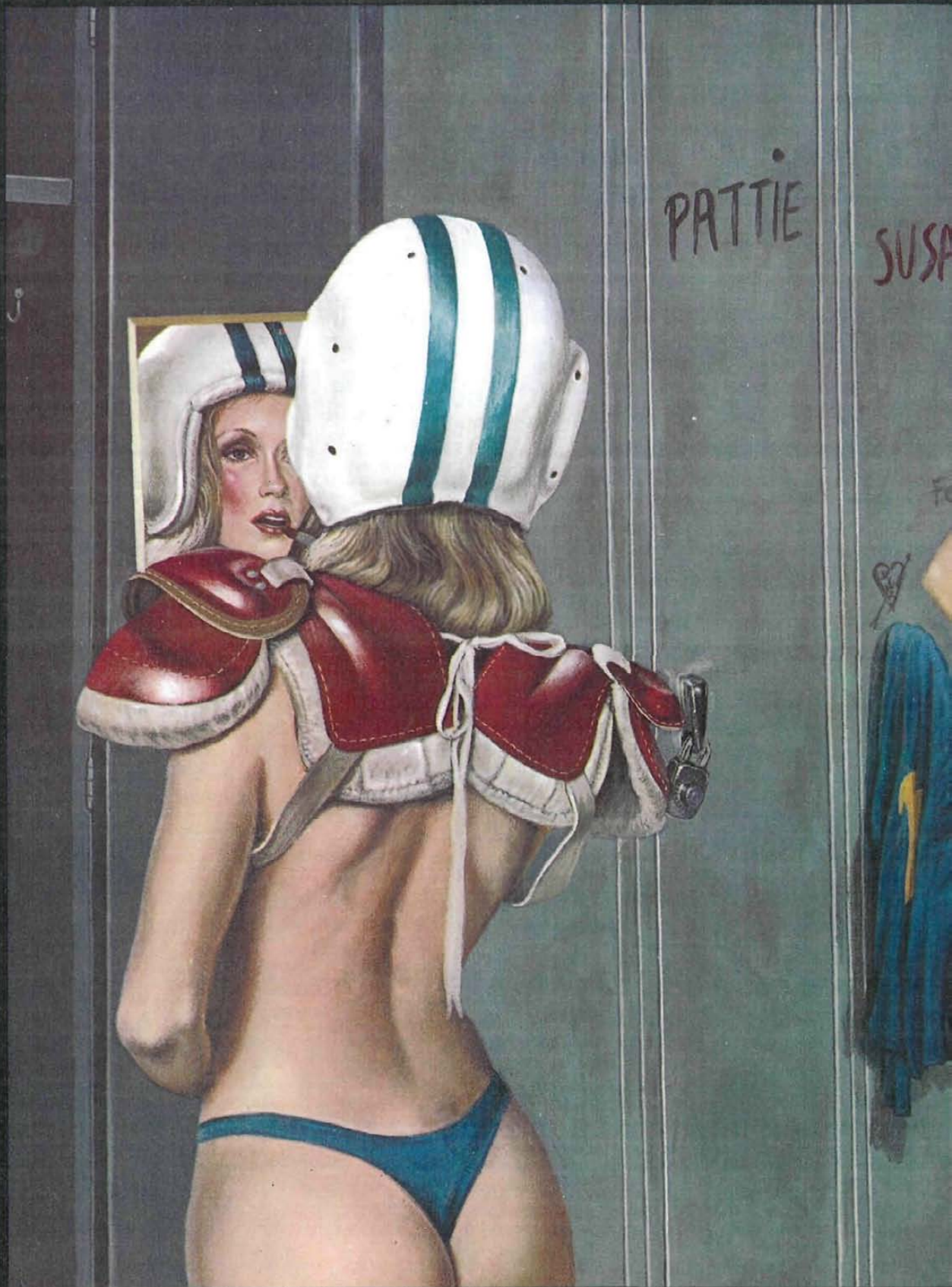

PATTIE

SUSAN





Sanderson, P, Boston AL

# Baseball Man Disappears Fro

Police Search Boarding Ho  
After Landlady Reports  
Loud Scuffling in the Night

Special to The Washington Star Journal

EVELAND, Ohio, May 30—It is n  
feared the life of the Cleveland An  
ortal peril, following an incident in  
stairs room of a boarding house



Huckstep, C, Bklyn NL

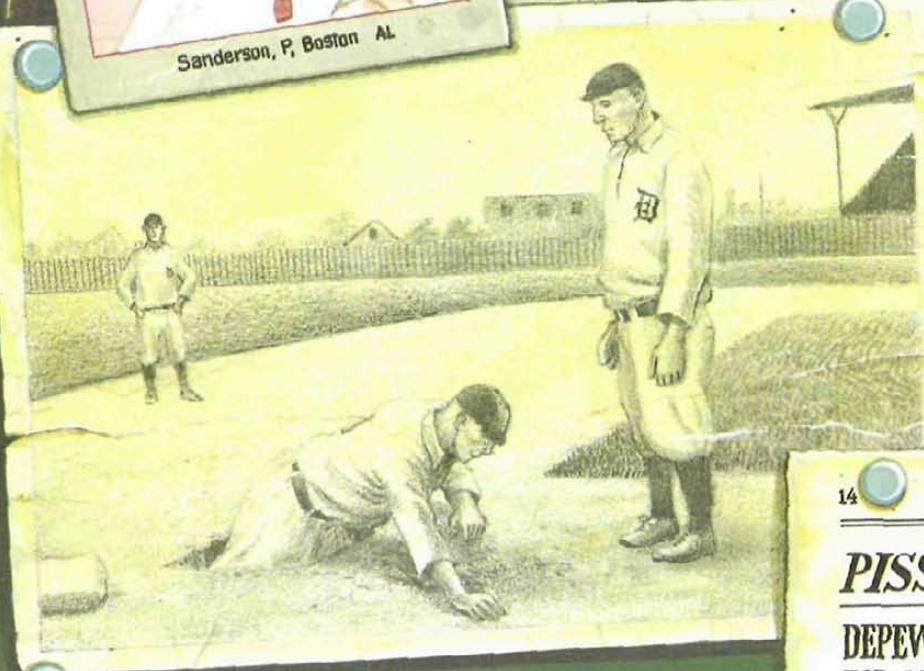

# PISSBALLER HURLS NO

DEPEW SOAKSTRIBE  
FOR 41ST WIN OF '13

ief Wampus Gets on First  
After Pulling Hatchet  
and Chasing Umpire

Special to The New York Times

SHINGTON, June 23.—Rookie  
tcher Ebos Derraw hurled a perfect  
hit, no-run  
ed his M



Depew, P, Wash. AL



Fomeen, OF, Phila. A.L.



# THE GLORY OF THEIR HINDSIGHT

**The Boys of Summer Became Old Geezers and Now They Play the Winter Game—Gabbing**

WRITTEN & ILLUSTRATED BY BRUCE MCGALL

## Five-Finger Felix Cudahay

He sees the people come and go,  
He feels Time's feathered wing brush by,  
Nods his head sagely, and says he,  
"Indubitably...indubitably..."

—Sara Henderson Ray

Never forget the day when the letter came from the Chicago Intelligents Baseball Club with the train ticket to Shamokin, Pennsylvania, in it. My dad, he cashed in that ticket and shoved me out the door, and I was on my way to Shamokin in the old Pie-Eye League.

They cuffed me around for reporting late and I lost my glove on the hike, but you couldn't hold me down. Got a good night's sleep, borrowed an old potholder from the landlady at the boarding house, and I was rarin' to go. Used that potholder for a glove my whole career.

That's where I picked up the nickname of Five-Finger Felix Cudahay, at Shamokin. Know who else was on that club in 1901? Chief Wampus. My, that big fella could hit the ball! But he was just a terrible-tempered man and I was glad when the Cleveland club bought up his contract and he was gone. I wasn't the only one, either. Every club the Chief played on, you see, the manager would disappear. You'd hear awful noises late one night in the boarding house and next morning...no manager. But nobody ever asked questions. Remember, the Chief was a full-blood Cree.

But you can't take anything away from the old Chief, that man could hit the ball. Saw him do an exhibition once, out in Sioux City I think it was, around 1915. Didn't even use a bat, just his fists. Ten straight homers.

Well, the Chicago club brought me up the next spring, 1902, and I stuck. Played there twelve years before Mr. Comiskey got mad at me over salary and I went over to Detroit. He'd been paying us in play money. That got to rankle me, so I guess I blew my top. Boom! I was gone. Detroit, then over

to Cincinnati, and then back to Chicago in 1918. Mr. Comiskey was paying you by the inning then, in real money. I had one or two more good years left, I reckoned, and I was tickled to be back with Chicago playing for old Frenchie Cuba. Best manager of 'em all, in my book. Frenchie let you alone. In fact, he sat in the stands instead of the dugout.

But as soon as I got out there I met Kid Caboodle and the Kid says, "Well, so long, Felix, I'm gone." Now, Kid had been on the Chicago team for a dog's age, so I ask him what he means. He says, "Haven't you heard? Mr. Comiskey just sent me to Cleveland for Chief Wampus." Well, oh my, I was just sick at heart. I tried finding Frenchie, but it was hard in those grandstands. Well, at first they thought he'd just got lost, but some of the other boys on that club had played with Chief Wampus before, too, and we all knew.

But overall I have no regrets. Playing ball for the Chicago Intelligents and later on the White Sox and being in the Major Leagues. My, it was a wonderful, wonderful thing.

## 2 Peaches Kling

Where did you come from, baby dear?  
Out of the everywhere and into the here.  
—George Macdonald

I was napped by the Hagerstown, Maryland, club of the old Gypsy League on July 4 of 1899. We called it napped. Short for kidnapping. That's how most of the boys broke in back then, you know. Clubs didn't want to pay for a ballplayer, so they just went and took him. That was napping.

Well, I did pretty good with that club, so then I got napped by the New York team later that same season. You ask about playing in New York in 1899. Now, the team hadn't any name. Neither did the ball park. It was just a bit of grass down by the Pennsylvania Rail Road tracks, Park Avenue and

Thirty-fourth. Trains came rolling right in through center field and cut left just behind the mound, turning into Pennsylvania Station a few blocks west. Never forget the series with the Braves that year. Needed one more game to win. Top of the ninth, old Jass Upsey just waits out there on the hill...he knows the 4:50 from Philadelphia will be due any minute. Sure enough, puffa-puffa-puffa, here she comes and there's this big cloud of smoke and steam and hot cinders flying and just then is when Jass rears back and throws. Struck out the whole Braves side with one pitch. Won us the Series.

I mentioned napping back there and the clubs' being too cheap to buy players. My, they were cheap! Never did get a uniform on that New York club, we just wore our street clothes with "New York" scribbled in chalk on the breast pocket.

Spring training we went south...ten blocks south. Trained down in that little park at Twenty-third Street just across from the Flatiron Building. That still there? February it was, cold as hell. All we had for equipment was rolled-up magazines held tight with elastics and snowballs. The bat boy was the owner and manager too and he stood up on the roof of the Flatiron Building...now the reason I keep harping on the Flatiron Building is this. You couldn't quit practice for the day until you threw one snowball clear over that roof. It was supposed to strengthen your arm—remember, this was way back before the home run era, when it was half a mile out to the center field wall from home plate. My feeling is, it ruined a lot more arms than it ever strengthened, but that's one man's opinion. I had to stay till ten, eleven at night, not a soul to be seen and snow falling and slush getting all in my shoes. Down there on Twenty-third Street, chucking the Goddamn snowballs up at the Flatiron Building.

Well, of course I moved on. The  
*continued*

## Glory of their Hindsight

continued

Boston club napped me in 1903. Got out of the boxcar and somebody took off the blindfold and this stout, red-faced fellow makes a flowery little speech welcoming me to the city of Boston. Found out later this was Mr. Memley, the owner. The Mexicans napped him awhile later, by mistake I heard, but mistake or not, Mr. Memley never came back.

Oh, Boston was a grand baseball town, though! Fellows on the St. Louis and Baltimore clubs would see the Boston napper and grab their valises and make themselves look mighty available. Hoping, you see, to come with the Boston team. But we had Dork Rademacher, Hum Shebago, Seth Feeny, and who else? Well, of course, James Whitcomb Riley Frazee, best left-handed pitcher I ever saw, so that was a hard lineup to break into. Flopper Lackaday, too. Could have been one of the great ones, but he had bad woman trouble. His wife sat right there in the dugout, keeping an eye on him.

Oh, that Boston club had so much talent! We'd punch and kick and rattle in the dugout before every game, fighting for a starting spot. This was before managers, remember, it was every man for himself. One kid, Stooze Sanderson, he wouldn't fight. Awful shy. Well, he was on that Boston club ten years and he never got one game in. Stayed to himself in corners and dark places, so the nappers from other clubs never found him.

Then, in August of 1906 somebody gets the drop on me from behind while we're brawling it out for that day's lineup. Now I was a big, strong fellow, but a bat right on the noggin...ouch! Well, my average fell off to .600 or so, and I had double vision so my fielding suffered, too. Wasn't long after that, Washington came up and napped me right off the boarding house porch. The other players just stood there watching it. Not one of them tried grabbing me back.

But tell you the truth, I wasn't worth grabbing back by then. That Washington club—they were called the Congressmen then, Senators came later—it was real weak, but even so I couldn't break in except for pinch-hitting. Got so they were suggesting I hang around the porch after supper. Hoped a napper would get me, take me off their hands. But nobody did. Not even the nappers wanted me by then.

Well, that's when I decided to hang 'em up for good, and I did. I did all right after, for a broken-down old ballplayer. Steady jobs, then a seat on the New York Exchange, place in Switzerland, and so on. But playing in the Major Leagues back then, I still think about it a lot. Being a ballplayer...now, that was something.

### 3 Zube LaRue

Lives of great men all remind us  
As their pages o'er we turn  
That we're apt to leave behind us  
Letters that we ought to burn.

—Abraham S. Wolf Rosenbach

Did you know Babe Ruth was a woman? Real name was Ruth Herman. Wouldn't have believed it either if I hadn't seen the proof with my own eyes. Got a tryout with the Baltimore club along with a bunch of other kids, this would be 1905. Same year Ty Cobb came up to the Tigers, I remember. They called me "another Ty Cobb" down in the Mediocre Association, and the Orioles were going to give me a good look. But nobody paid any attention that day, everybody was watching this ugly little fat girl in a dirty white pinafore just ripping hell out of the ball. The kids on the sidelines said, "Oh, don't mind her, that's Baby Ruth Herman from the neighborhood." Well, we *did* mind her, I can tell you! Manager sent her on home, of course, baseball then being strictly a man's game. God amighty, never forget the shock about ten years later up in Boston! Never had the heart to squeal on her, and neither did anybody else. Amazing thing, Ruth Herman, "the Babe."

I'll tell about another amazing thing that I found out when I moved over to Detroit, but this is nasty, a nasty thing. Amazing, but nasty. Bet you never heard before about Cobb's Tunnel? Well, that Ty Cobb was one sneaky little bastard, that's the nub of it. How sneaky, that tunnel of his showed. Made me ashamed of being called "the new Ty Cobb."

Now, Cobb came up early one spring from Georgia where he lived and he hung around the ball park—this was the old Navin Field out on Michigan—just to study, he said. The place was empty, this was in March, so who'd know what the hell he was doing? Just like Cobb to go sniffing around a ball park looking for ways to pull his dirty tricks. Nobody gave it any thought.

Of course, the cheating little son of a bitch was busy digging his tunnel. Dug it straight under the mound from first over to third. Entrance under the first base bag, exit under the third. Oh, that was quite a routine he had going for him. Just slap a dinky single past second and then that famous slide into first. Only reason he slid was to kick up a dust cloud. Cobb would be under the bag and into the ground like a ferret and up he pops over at third, credited with a three-base hit or a two-base steal. Great competitor, my ass. Just a common cheater if you ask me.

My, I haven't thought about the old days in so long. Thinking of Cobb and Ruth Herman, say, that brings back the memories. Good memories. Those ballplayers then, they were a grand bunch of fellows, with only one or two exceptions. Did you know Honus Wagner was a fairy? Him and Walter Johnson, I could tell tales. Both of them in an upper berth...you dreaded those long overnights.

But I never was a knocker and I won't start now. You ask me about Major League ball in the old days, I'd just say that was the life and I'd leave it at that. Let sleeping dogs lie. Let the dead stay buried. Probably gabbed too much for my own good already. Get out.

### 4 Fred "Two-Glove" Beidermeyer

"I find," said 'e, "things very much  
As 'ow I've always found,  
For mostly they goes up and down  
Or else goes round and round."

—Patrick Reginald Chalmers

I'm talking 1901, 1902, and in there. You had to walk or sometimes run between towns, so a long road trip was something everybody on the club dreaded and in particular the older fellows. The run from Cleveland over to New York, those hills around the Alleghenies...that was murder. Then back again a couple of weeks later. Middle of the night, climbing up through those mountains all loaded down with your bat and your spikes and your duffel bag and knowing you had a doubleheader next day. That was as close as I ever came to giving up playing ball and going on home, those road trips. Oh, we'd pass the time talking baseball or tossing rocks, but I don't think any man could keep from getting downhearted, sooner or later. Even a cheerful fellow like Rube Snifter, always singing and joking...

continued on page 83



Official  
U.S. Olympic Team  
Orientation  
Handbook

~~50¢~~ Only 25¢ for team members and their families

**Official U.S. Olympic Seal**

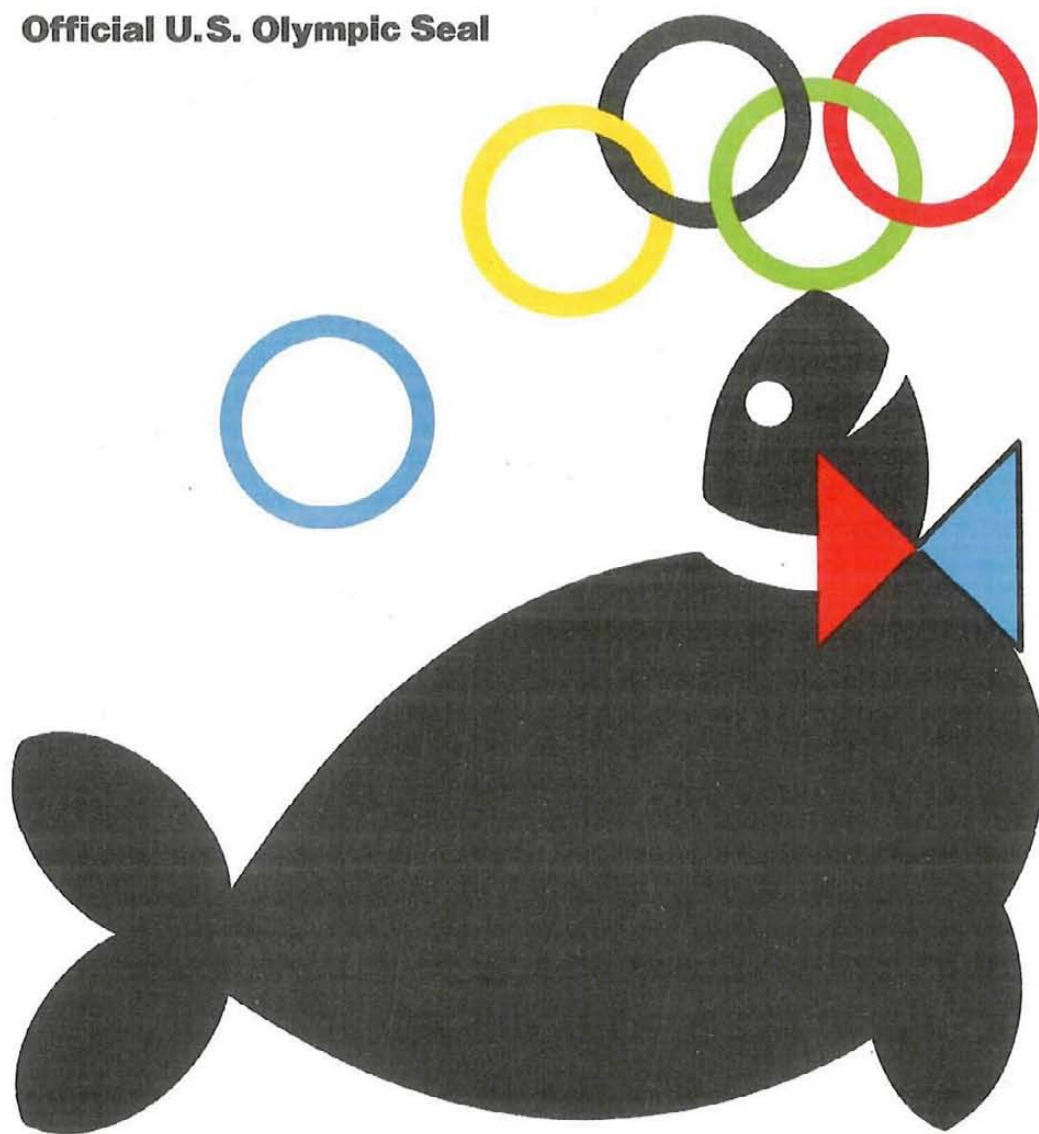

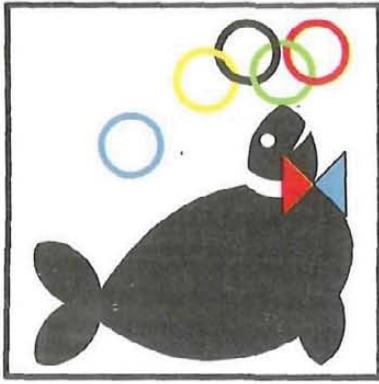

## United States Olympic Committee

Congratulations! You finally made it to the top—to the dream and the glory, to the triumph and the tragedy, to the agony and the ecstasy . . . to the Olympics! Your country is proud of you. In fact, we're damn proud, but we're also a little low on money this year. We wanted to spend more, but protecting our national interests and the security of our allies costs money. However, to coin a phrase, necessity is the mother of invention, and your Olympic committee has not let finances stand in the way of putting together this Fun-Pak and Handbook for all members of the team. It's full of things to do, places to see, and hundreds of discounts on the things you'll need to get the most out of your Olympic experience—things like food, clothing, and shelter. We think it is the best Olympic package, bar none, ever put together for any Olympic team.

So . . . best of luck, and don't take any wooden starting bullets.

*President Richard M. Nixon*

Richard M. Nixon  
Honorary Chairperson  
U.S. Olympic Committee





### Getting to the XXI Olympiad

For those of you who are really "into" physical conditioning, your committee has devised a novel means of transport to the Games. We call it the Bicentennial Run and Conditioning Walk. Starting under the Gateway Arch in St. Louis, we will run up the Ohio as far as Pittsburgh, the Super Bowl town. From there, it's a right turn to Albany, and then up the Northway, called by *Look*, the Official Former Magazine of the XXI Olympiad, "the most scenic highway in North America." There are convenient rest stops every twenty miles or so at attractive and exciting Hot Shoppes, the Official Rest Stop of the XXI Olympiad. Ask your coach about our special Discount Meal Books, which are only available to team members and their families. Don't miss the "all you can eat Fish Fry" on Wednesday night. It's only \$2.95, and you get a *free* glass of apple juice on us!

If you want a more luxurious style of travel right out of the "grand tours" of yesteryear, we have arranged transportation via a fleet of modular flatbed container trucks provided by Fruehauf, the Official Modular Flatbed Container Truck of the XXI Olympiad. For only 59 cents a pound (the first twenty pounds are on us), a spanking new Fruehauf will pick you up at one of two convenient rendezvous points and whisk you off to Olympic City in Montréal, Canada (which appears on your map as a pink country, due north of the U.S. of A.).



### Your Olympic Equipment

Within a few days, a liveried employee of the U.S. Postal Service will deliver a festively wrapped, impact-proof parcel to your door. It will contain one pair of white socks, a tank top jersey, one pair of shorts, and a warm-up jacket. You may, of course, want your name, number, and country indicated on your uniform, and we've thought of that, too. For \$8.95 we will send you an Official Olympic Sew-on Patch Kit, designed by Simplicity Patterns, the Official Sewing Pattern Maker of the XXI Olympiad. Each kit contains a full set of *all* the letters in the English alphabet plus a *complete* set of Arabic numerals, *including* zero. You also get the signs of the Zodiac and pictures of your favorite recording stars. This is your chance to "let it all hang out" and put a little bit of yourself into the Olympiad. After all, we at the committee feel very strongly that this is *your* Olympics.

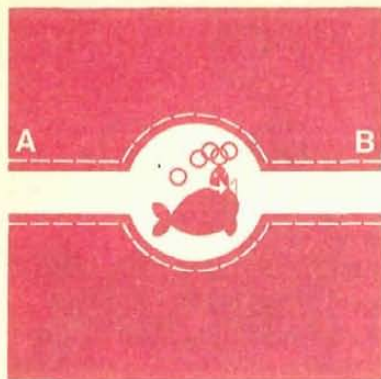

### Your Olympic Ring

The Official Olympic Ring has long been the most cherished and sought after American sporting ornament, and this year's ring is better than ever. Cost crunch or no cost crunch, we went out and asked one of America's top graphic artists to design this year's ring (we can't tell you his name, but you've followed his comic strips in over seventy U.S. newspapers). To assemble your Olympic Ring, simply cut along the dotted line and fold flap A so that it overlaps flap B. Apply a dab of Elmer's Glue, the Official Adhesive Bond of the XXI Olympiad, and you've got yourself a ring to show off for many weeks to come. Athletes with a more mod flair will want to own the Official Olympic Mood Ring, available for \$14.95 with every full tank of gas you buy at participating Sunoco dealers, the Official Gasoline of the XXI Olympiad.



### Your Stay in Olympic City

While you prepare for competition, you will be housed in the gaily decorated "Olympic Village," which the Canadian government has promised to complete sometime around the start of the Games. The "rooms" are equipped with every modern convenience, including an *unlimited* supply of hot water and electricity. (There's no shortage of safe and clean hydroelectric power in Canada!)

Once you've competed, you may elect to stay on for the rest of the Games, and we've worked out a not-to-be-undersold "bed and breakfast" plan for only \$14.95 a night. Our dorm chief, Mr. Snyder, can also help you out with an economical "two-for" plan if you're traveling with your "spouse" (no questions asked).

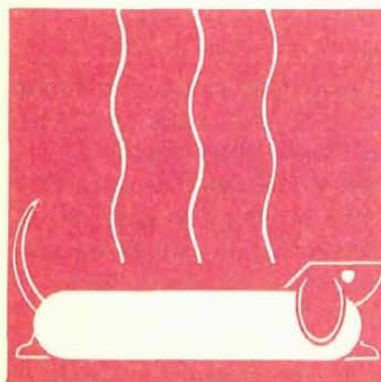

While you ready yourself for that big event, you will dine on gourmet meals prepared by our team of kitchen magicians from the International House of Pancakes, the Official Caterers of the XXI Olympiad. IHOP has created an official U.S. Olympic Pancake for our team that contains the minimum daily requirements of all the vitamins and minerals you need in a "one-plate" dish. *And* it's colored red, white, and blue (only harmless edible food coloring is used, of course).

After your event, we have a very inexpensive Athlete's Meal Book which will provide you with nourishment for the rest of your stay. And you can believe us when we tell you that we have spared no expense to give you the vital nutrition that young people need. Each and every bowl of Olympian's Gruel provides more than twice the annual protein intake of the average Bolivian, and the cost to you is a very economical \$3.95 (Continental breakfast \$1.95). There is only one rule to remember in the dining halls . . . *no seconds*.



After a hard day at the Games, you'll want to unwind in our Coupe de Razoire Lounge, designed with the "now" athlete of today in mind. Enjoy a full selection of wine, beer, and spirits at the lowest prices anywhere. Because we use "house brands" instead of nationally advertised brands, the *savings* are passed on to *you*. There is a two drink minimum at the Coupe, but there's no cover charge, and you can dance the night away to French language versions of the very latest disco sounds on our Mixed Doubles juke box.



### **In Case You're Kidnapped**

Kidnapping has become a very real problem at the Olympics. It is particularly in vogue among the Palestinians, who are barred from other events.

We are prepared to pay up to one hundred dollars ransom for U.S. Olympians (medal winners rate \$225). We did try to obtain free coverage for all of you, but it seems that athletes are put in the high risk category because of the strenuous nature of their work. You really wouldn't believe some of the outrageous premiums we were quoted. But after careful searching, we came up with an economical two dollar-a-day plan from Prudential of Port-au-Prince, the Official Caribbean Insurance Company of the XXI Olympiad. The coverage is completely voluntary, of course, but if you're the kind of people we think you are, the kind who really care about family, you'll want to take advantage of this attractive offer.



### **Our Olympic Hosts**

None of us at the committee have ever been to Canada, but we heard it's a wide open town. Our travel agent in Montréal, Tex Carling, Minister of Tourism, Cultural Affairs, Mining and Fisheries, has provided us with an inviting portrait of the city that has been called "The Paris of the West" by those who have never been to France:

Les Montréalais (*mon-ray-ah-lay*) are justly proud of their Eskimo tradition and have taken many lessons from these denizens of the north who roamed Quebec (*kay-beck*) Province before they became obsolete in the seventeenth century. For example, Montréalers regard it as a social duty to share their women with foreign visitors. Although this practice has become somewhat Europeanized in recent years, a case of Pepsi Cola will guarantee you a "night to remember" with a winsome Montréal lass.



### **In Case You Strike Out**

Mr. Ralph Snyder, our jack-of-all-trades, has arranged for locally recruited Olympic "cheerleaders" this year. These gals are full of the Olympic spirit and Mr. Snyder has personally tested each and every one of them for cleanliness and "cheerleadability." These "talented" girls will provide expert "cheerleading instruction" for \$5.00 and up, depending on the "cheer."



### **Financing the XXI Olympiad**

As we've already explained, money is a little tight for this year's Olympiad, but if each of you remembers that you are not only athletes but Official Olympic Salesmen, we should have no problem in Montréal.

Just to get you started, we've devised a pleasingly offbeat idea for the ceremony held at the opening of the games. The Procession of Athletes, with its thousands of clean young bodies and bright, new uniforms, is a stirring and moving sight that is seen in over ninety million homes around the world. This year, the U.S. team will march in the procession with a new addition to their uniforms: the Official Olympic Sandwich Board. Just think of the promotional mileage your local Sunoco dealer will rack up as he sees the words "Bob's Sunoco—We Fix Flats" emblazoned across the chest of his favorite Olympic star. Best of all, you get a whopping fifteen percent commission on every line of advertising you sell!

We don't want you to feel pressured into selling, if that's not your "bag." But we promise you here and now that everyone who brings in their quota of \$10,000 in sales will receive undetectable medical "boosters" that virtually guarantee a silver or bronze medal. And if you do join the \$20,000 Golden Track Shoe Club, our doctors will inject you with the super performance enhancer Velocidril, guaranteeing a gold medal for sure. So get out there and sell, sell, sell.

### **Important Note.**

Don't talk to any recruiters from professional sports.

You could jeopardize your amateur status.  
Copyright © 2007 National Lampoon Inc.

# SPORTS COMEBACK OF THE YEAR

**Babe Ruth Comes Back from the Dead to  
Lead the Yankees to a Second Place Finish**

by Gerald Sussman

Illustrated by Rick Meyerowitz

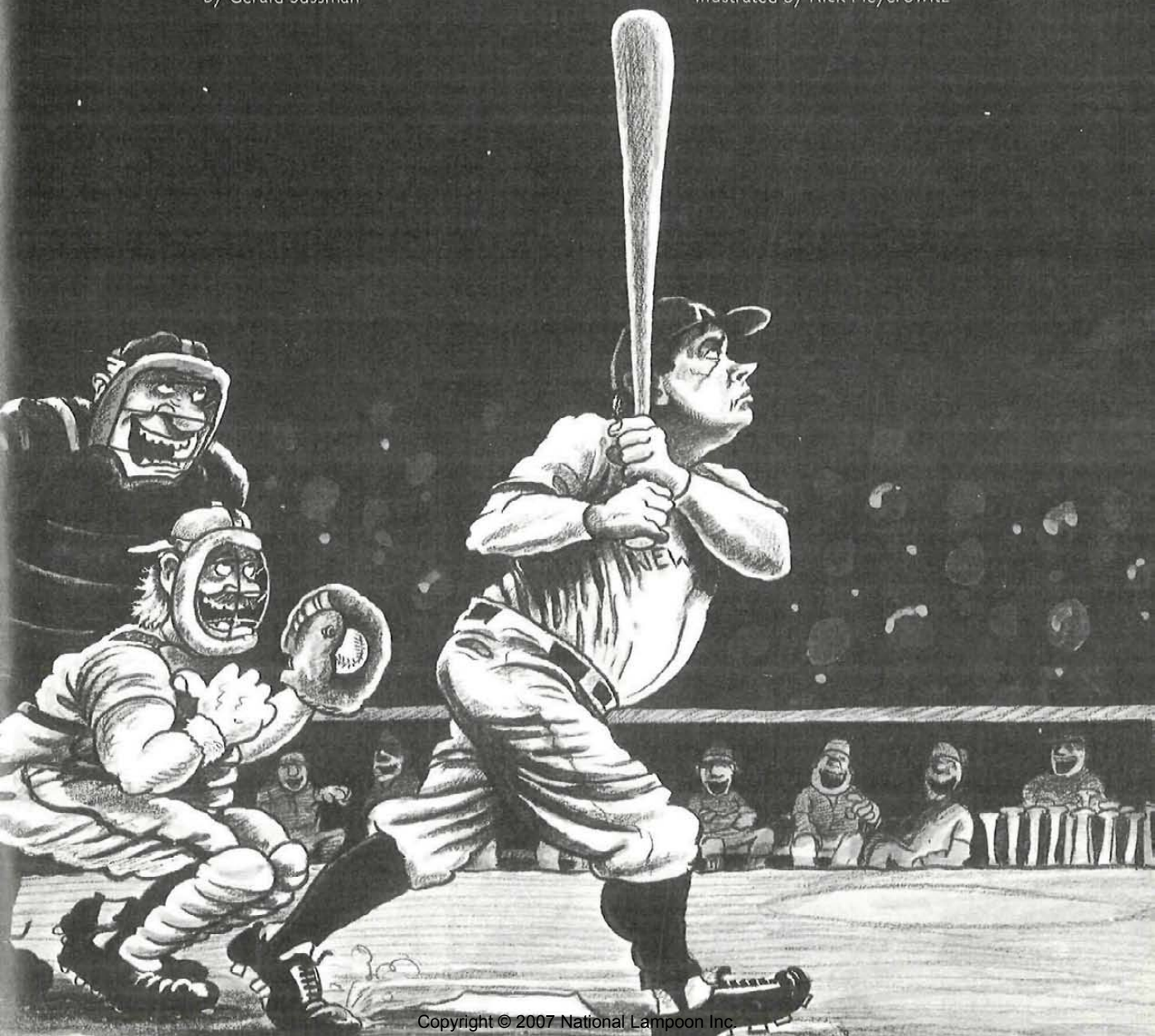

---

## The Pointless Moment: The Called Shot Grounder

On September 14, 1976, in a crucial game with the Orioles, did the Babe actually point to the ground and hit a ball precisely to that spot? Eyewitness reports differ. Oriole catcher Earl Williams said that Ruth pointed to the ground because he saw a mouse on the infield. (Oddly enough, the mighty Bambino was terrified of mice.) Teammate Catfish Hunter kidded him afterward. "What would have happened if you swung and missed? You would have looked like a bum," said Hunter. "I am a bum," said Babe. "We're all a bunch of bums."



---

## An Inspiration on the Field

The Babe's incredible batting exploits always overshadowed his substantial gifts on the field. Today, some of the old speed is gone, but the desire and moxie are stronger than ever. "He can't remember any of our signals, so he gets picked off easy," said third base coach Dick Howser. "But how can you be mad at a guy like that? Just the idea of a man his age running the bases is enough to really spark up the team."





## The Babe Tries to Live Up to His Legendary Appetite

With two out and the bases loaded in the top of the ninth, Fred Lynn of the Boston Red Sox hit a long fly to right field. The Babe was playing it perfectly, but at the last second he got that famous urge for hot dogs. "What can I say?" cried manager Billy Martin in semi-mock exasperation. "He can't even eat two wieners anymore, but he keeps trying. Then he complains of a bellyache. Eighty-one years old and he's still just a big, crazy kid."

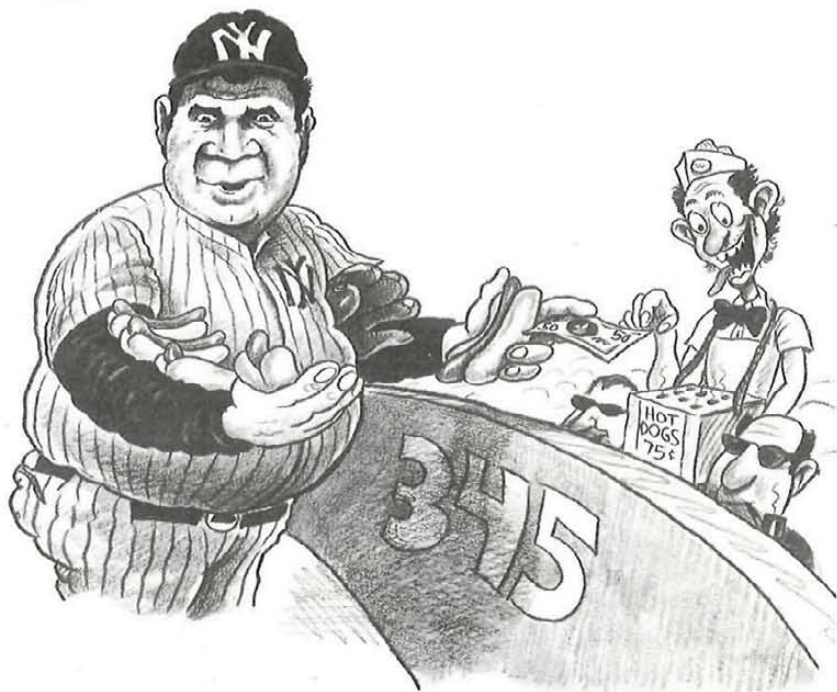

## The Big Confrontation

It was inevitable for the Babe to meet the man who broke his all-time home run record. Everyone wondered what he would say to Henry Aaron in this momentous meeting. The Babe was always used to hogging the limelight. Would he be jealous? Would he sulk or erupt into a childlike temper tantrum? No. Everything went just fine. The Babe said something about "records were meant to be broken" and hammed it up for the photographers, just like the old days.

WHO'D A EVER THINK IT... A NIGGER, IN THE BIG LEAGUES!



## An Inspiration to the Sick

Off the field, the Babe still gives of himself unsparingly, visiting hospitals, autographing baseballs, and cheering the ill and infirm. "That's not his stomach. That big wonderful paunch is his heart," said the father of young Johnny Sylvester, a dying boy who almost recovered, thanks to the Babe's visit.



## For the Jock Groupies the Babe was a Brand New Trip

The Bambino was no bambino in the sex department. Oh, no! Here is where myth and legend were one and the same. No sex story was too apocryphal when it concerned the Babe. Today's liberated females are more curious than ever to try out his legendary "Louisville slugger." And as far as the Babe is concerned, the nights are still made for booze and bimbos. □

WHADDAYA MEAN WE PLAY BASEBALL AT NIGHT? THAT'S CRAZY!



JBL's new L166.



\$375 each.

**(800) 243-6100**

We want you to hear JBL's newest bookshelf system, but we want it to do the talking.

If you listen to us, we'll get into "dispersion" and "definition" and "power handling capability" and "frequency response," because JBL's new L166 has more of all four than any bookshelf loudspeaker we have ever built.

But specs are not sounds, and words are not music.

Go hear the L166. It's easy to do. Pick up a phone. Call the toll-free number. Tell them where you are, and they'll tell you where your nearest JBL dealer is.

The L166. Now that you've gotten the word, try the number.

High fidelity loudspeakers  
from \$156 to \$3210.

**JBL**

# Surprise Poster #77





**OLYMPIC  
VILLAGE  
1 KM**

*punchatz*

# FOTO FUNNIES



JUST LAY YOUR ROBE OVER THERE, NUMBER FOUR, AND WE'LL READ THROUGH THE...



SAY, YOU CERTAINLY ARE BUILT LIKE A BRICK SHITHOUSE! WHAT DID YOU SAY YOUR NAME—?



HLIH?

FOR YOUR INFORMATION, I HAVE ABOUT HAD IT!

ALRIGHT! THAT'S IT! HOLD EVERY THING!

HEY, TAKE IT EASY...



SURE, MAN! IF THAT'S THE WAY YOU FEEL ABOUT IT...



FOR THREE YEARS NOW YOU'VE BEEN GETTING TO POSE NUDE WITH AN ENDLESS SUCCESSION OF SEXY WOMEN! WHILE I SIT BACK HERE JERKING OFF WITH THE FUCKING CAMERA! WHAT DO YOU THINK I'M MADE OF? STONE?

NO! I WILL **NOT** TAKE IT EASY! RIGHT NOW—TODAY—I, PETER KLEINMAN, AM GOING TO BE IN A FOTO FUNNY WITH A NAKED GIRL WITH TITS!

HERR KAPITAN, BRITISH DESTROYERS! PLEASE TO LOOK THROUGH DER PERISCOPE!



RIGHT! RIGHT! SHE'S ALL YOURS!

YOU BET I DO! NOW GET OVER HERE AND TAKE THE CAMERA!



HEY, PETER, IS THIS THE THING I PUSH?

VAS?

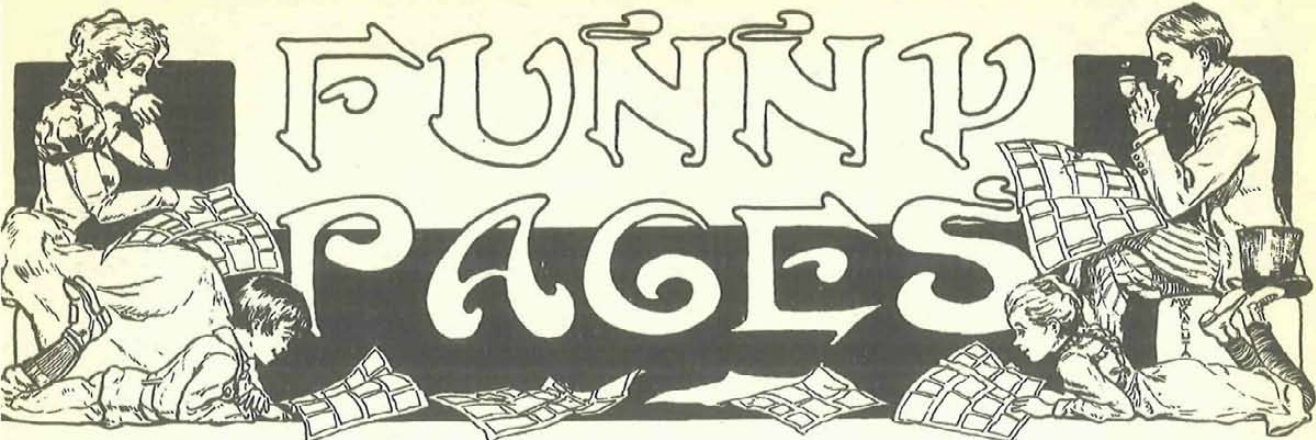

**ENUTS**

REMEMBER HOW TERRIFIC THE COMIC BOOKS WERE? ALL THE SWELL, EXCITING STUFF THAT WAS IN THEM? AND WONDERING WHY IT WAS ONLY KIDS SEEMED TO REALIZE THEY WERE GREAT?

BOY-THIS CAPTAIN POWER IS REALLY GREAT, ISN'T HE? AND THAT ROCKET OF HIS IS SOMETHING!

HE'S PLENTY GOOD, BUT I LIKE DOCTOR SCIENCE AND HIS LAB AND ALL!

CAPTAIN POWER

YOU CAN HAVE STRANGE POWERS

DOCTOR SCIENCE

GEE, HERE HE'S ON MARS AND CAUGHT BY THE WALKING MUSHROOMS!

ARE YOU KIDS GOING TO BUY ONE OF THOSE?

YOU'RE STRONG

YEAH, BUT LOOK WHERE DOCTOR SCIENCE HAS ACCIDENTALLY GOT SHRUNK AND THE EVIL PROFESSOR'S GOT HIM IN A BOTTLE!

THIS IS A BUSINESS, NOT A LIBRARY!

KILLER COMICS

AT LAST I'VE GOT YOU IN MY POWER, DOCTOR SCIENCE! DO YOU WORRY YOU WON'T?

HERE YOU ARE, MR. SCHULTZ.

HERE YOU ARE, MR. SCHULTZ.

HIGH TIME.

EL PRIMO

EL TORRE

IT'S FUNNY HOW MR. SCHULTZ IS SUCH A GRUMPY PERSON. YOU'D THINK HE'D BE HAPPY WITH ALL THOSE GREAT BOOKS AROUND.

MAYBE HE DOESN'T REALLY APPRECIATE THEM.

Gahem Wilson



# Dirty Duck



by  
BOBBY  
LONDON



HOW ABOUT YOU AND I GOING ON A DOUBLE DATE, WEEVIL? I MET TWO LOVELY BISEXUAL LADIES LAST NIGHT AND...

NO THANKS, MR. DUCK... I'VE TAKEN A VOW OF CELIBACY!



HOW WHOLESOME OF YOU~ WHY?

LUPE THE SPANISH FLY DUMPED ME FOR AN ENTIRE ANT COLONY!



WELL, BEFORE YOU GET A FULL TIME JOB AT THE VATICAN, TAKE A PEER AT THIS!

NAAAAH!



LOOKS LIKE FUN, DOESN'T IT?

LEAVE ME ALONE!!



RE-MEMBER HOW NICE IT FELT?

PLEASE, MR. DUCK, DON'T DO THIS TO ME - I'M NOT WEEGL... LIFE IS FAR TOO COMPLICATED FOR ME TO CONCE-IRATE...



...ICH HABE DIE LIEBEKRANKHEIT!



THERE'S ONLY ONE WAY TO BRING THIS BOY BACK TO EARTH.

JA DAS IST DIE LIECHTEN-STEINER POLKA, MEIN SCHATZ!..



HELLO "PUSSY DELIGHT"? I'D LIKE TO ORDER A 30 YEAR-OLD FEMALE, WELL-DONE, TO GO...

ICH BIN GOTTZICH!

ZIEG HEIL!



KNOCK KNOCK

NOW THAT'S WHAT I CALL SHORT ORDER.

COMING!



H!... WHAT WOULD YOU LIKE, HONEY?



I'D LIKE YOU TO SERVE THE FUHRER, HERE.



NEIN! NEIN! ICH WILL ES NICHT!!

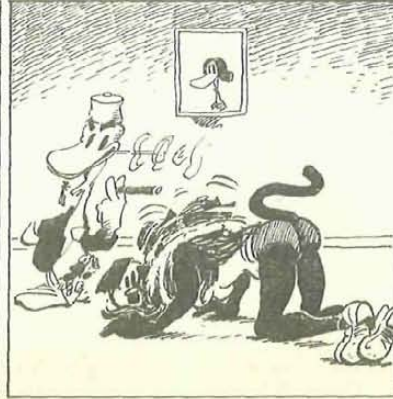

ABOUT THAT DOUBLE DATE MR. DUCK...

FORGET IT, I'M BROKE.



STEVE AND JILL ARE ENGAGED! WITH 5 WEEKS REMAINING, COULD MARRIAGE BE THE END OF THEIR ONE YEAR AFFAIR?

STEVE, IF YOU REALLY WANT TO GET US SOMETHING, BUY US A TOASTER OVEN! AT LEAST THAT COOKS FISH STICKS!

JILL, DON'T BE RIDICULOUS! I DON'T WANT TO BUY US ANYTHING! I WANT TO BUY YOU AN ENGAGEMENT RING!

YOU'RE NOT WALKING DOWN THE AISLE WITH A TOASTER OVEN ON YOUR FINGER!

BUT I DON'T NEED AN ENGAGEMENT RING!

HENCE!

OH STEVEN! IT'S BEAUTIFUL!

JILL... ABOUT THAT TOASTER OVEN...

OH STEVE, I DIDN'T THINK A RING WOULD MEAN THAT MUCH TO ME, BUT IT'S SO REAL! I USED TO DREAM ABOUT GETTING AN ENGAGEMENT RING WHEN I WAS A LITTLE GIRL...

© 1976 B.P.V.P.

I WAS A PRINCESS-- HE WAS A PRINCE, TALL AND DARK, WITH DEEP GREEN EYES...

TOASTER OVEN

HE PROPOSED IN A DEEP VOICE, WITH A SHINY LITTLE RING...

AT LEAST I GOT THE RING!

NEXT: THE SHOWER...

# FAMOUS COMIC ARTISTS SCHOOL

BY BRUCE COCHRAN

## LESSON # 30

### STINK LINES

SOONER OR LATER YOU WILL BE CALLED UPON TO DRAW SOMETHING SMELLY (A SKUNK, A TURD, A POLITICIAN...). THE SUBTLE TECHNIQUE OF STINK LINES IS THE ONLY SOPHISTICATED ANSWER.

RIGHT

WRONG

# HARD-BOILED DICK

THEY WERE TOUGH AND THEY WERE CORRUPT-- THEIR WORLD WAS SEEDY, SICK AND WILD-- THEIR CITIES WERE L.A., SAN FRANCISCO, CHICAGO THIS IS THE STORY OF ONE OF THEM, A PRIVATE EYE.

10:52 PM A BIRD NAMED SONYA HAD GIVEN ME 2 WEEKS TO FIND THE JOKER WHO TRASHED HER MICKEY.



"HER" MICKEY. POOR SONYA. "HER" HOOD HAD BEEN PUNCHING A FRAIL NAMED PATTY DE FOIE GRAS ON THE SIDE.



I TRACKED THIS ESA BAYO CANARY TO A ROACH HOLE IN THE WHARF. SHE WAS TENDING BAR UNDER THE A.K.A. JOIE DE VINRE.



STEPPING INSIDE, I MADE MY WAY THROUGH A MAZE OF SCURVY AND GONORRHEA. JOIE SPOKE FIRST.

WHAT'LL IT BE?

WHADDYA GOT?

HOW MUCH YOU PAYING?

WHAT'S THE CHARGE?

WHO'S ASKING?

WHAT'S THE DIFF?

WHAT'S IT WORTH?

FIFTY.

I'LL SHOW YOU MY PRIVATE STOCK.

FIVE MINUTES LATER A SALT-BITTEN HANDESMAN WAS TUGGING US UP TO BROADWAY.

11:14 JOIE FEISTED ME INTO A SQUALID CLAPTRAP IN THE MISSION DISTRICT. IF SHE WAS FRENCH, I WAS COLORED.

MAKE YOURSELF AT HOME, ABE, WHILE I SLIP INTO SOMETHING MORE COMFORTABLE.

COMFORTABLE? IN THIS MORGUE? I WAITED AND WATCHED.



THERE--

NOW WHERE WERE WE?

A LOONEY. I HAD A LOONEY ON MY HANDS AND FROM THE LOOK OF THAT TORCH, SHE MEANT BUSINESS. IF JOIE TRASHED MICKEY, SHE MIGHT BE OUT FOR AN ENCORE. NOT IF I COULD HELP IT.

# THE NEW, RAPIDLY IMPROVING, AESOP BROTHERS SIAMESE TWINS

THE VERY NEXT YEAR: THE DEFUNCT BROTHERS IN AN AUSTERITY MOVE HAD TO LET ALEX GO. GEORGE, STILL ON THE PAYROLL, WAS DISPATCHED TO THE STATE OF LIBERTY WHERE A CHINESE WAS BELIEVED TO BE RAPING MISS LIBERTY FROM THE INSIDE!

ALEX, BEING FIRED, JUST WANTS TO GO HOME. GEORGE HAS TO CHECK ON THE CHINK. GEORGE READS WITH ALEX - ALEX SAYS, NO! THEY ARGUE - GEORGE GRABS ALEX BY THE THROAT! ALEX SPOGS GEORGE IN THE MOUTH! A POLICEMAN VIEWS THE ASSAULT. ALEX MOUTHS OFF TO THE POLICEMAN. THE POLICEMAN PLACES ALEX UNDER ARREST! AS HE SEIZES ALEX HE DISCOVERS THEIR AFFLICTION AND A LEGAL DILEMMA!!!

I CAN TAKE SMART-ASS IN, BUT I CAN'T DEPRIVE THE OTHER GUY OF HIS LIBERTY.

WELL, HE CAN TAKE ALEX IN, BUT HE AIN'T TAKIN' ME! I'LL SUE!

IF HE ARRESTS ME HE'LL HAVE TO TAKE GEORGE TOO. AND THAT'LL BE ILLEGAL...

I'M NOT GOING TO GET IN THE MIDDLE OF A CAUSE CÉLÈBRE. I'LL LET HIM OFF WITH A WARNING...

...UH, - LOOK, YOU, I'M GOING TO FORGET THIS. JUST KEEP YOUR NOSE CLEAN AND WASH YOURSELF, MISTER!

C'MON, DO YOUR DUTY, IDIOT POLICEMAN!

HE'S PLAYING A GANG WITH ME...

HE CAN'T LET ALEX GET AWAY WITH THAT...

HE CAN'T LET ME GET AWAY WITH THAT.

THERE'S GOT TO BE A WAY OUT OF THIS...

YOU THINK YOU GOT ME IN A CORNER, DON'T YOU? WELL, LET ME.....

YOU'RE TRYING TO PROVOKE ME SO THAT I'LL BE FORCED TO ARREST YOU. THEN I'LL BE IN THE MIDDLE OF A LEGAL HASSE!

I'D BELT YOU MYSELF, ALEX, ONLY THEN I COULD BE PINCHED FOR ASSAULT!!!

PUUH-TOOOOO!

HEE, HEE, HEE, HEE, HEE, HEE, HEE

I GOT NEWS FOR YOU - I WON'T BE PART OF YOUR LITTLE CHARADE!!!

PPPPRRRRR!

YOU PUSHED ME JUST A LITTLE BIT TOO MUCH...

I'VE GOT AN OUT...

CONTINUED

PHIL GRUBB -- COLLEGE GRAD TURNED HOT SHOT JOURNALIST -- RETURNS TO HIS HIGH SCHOOL AS A STUDENT TO SEE HOW THINGS HAVE CHANGED ...

YOU WOULDN'T BELIEVE THE CLASSES, BILL! I'VE GOT A DATE TONIGHT WITH A GIRL I MET IN THE LUNCHROOM -- SHE'S SUPPOSED TO PICK ME UP ANY...



HELLO, PHIL -- THIS IS SUZANNE -- I DON'T THINK I'M GOING TO MAKE IT TONIGHT -- SOMETHING'S COME UP...



SEE -- UH, I DON'T KNOW, LET ME ASK HIM ...



UHM ... HE SAYS THERE'S NOTHING YOU CAN DO, PHIL ... SEE YOU IN CLASS ON MONDAY, ALL RIGHT?



STOOD UP, HUH, GRUBB?



NEXT: BACK TO SCHOOL ...

# "Getta JOB"

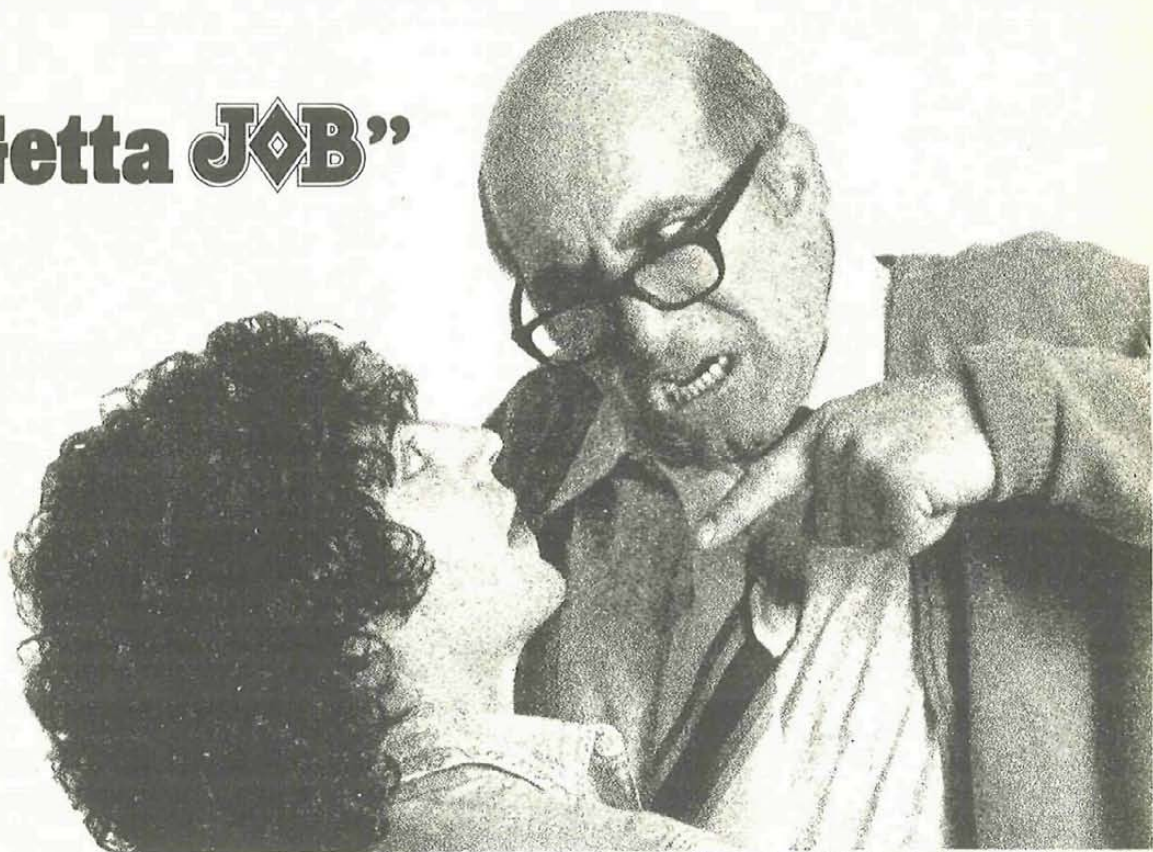

## Have we got a JOB for you

You may not have a job right now, but JOB, that French Cigarette Paper Company, is making an offer you can't resist.

We've put together a kit, containing four of our favorite easy rolling, clean smoking JOB papers.

For \$1, you'll receive one pack each of our two favorite, one lick, no mess, double wide papers—White and Strawberry. And for you die-hard, traditionalist, single paper rollers, a pack of JOB Wheat Straws and a pack of JOB 55's white.



## JOB APPLICATION

I certify that I am over 21 years of age.

**Adams Apple Distributing Company**  
Dept. NL-05  
2835 N. Sheffield • Chi., Ill. 60657

So, send me my JOB Sample Kit. I enclose my check or money order for \$1 to cover cost, postage and handling.

Name \_\_\_\_\_

Address \_\_\_\_\_

City \_\_\_\_\_

State/Zip \_\_\_\_\_

Only one sample to a family, please. Please allow four weeks for delivery. Offer good only while supply lasts.

BROUGHT TO YOU FROM FRANCE BY ADAMS APPLE DISTRIBUTING COMPANY • CHICAGO

1  
 Gilbert, fashionable but impudent young Count of Chateaugay, has but a few hours left in which to enlist a new chambermaid before the gala opening of his newest Parisian *Jour-n-Hause...*

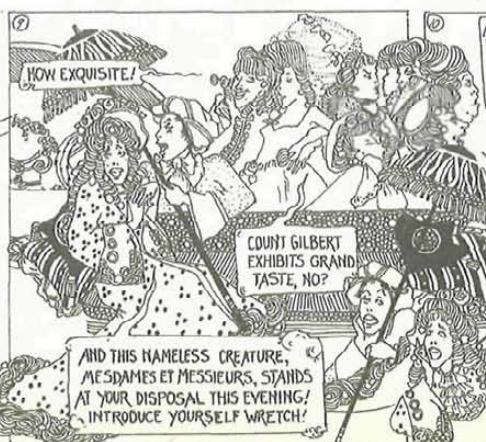
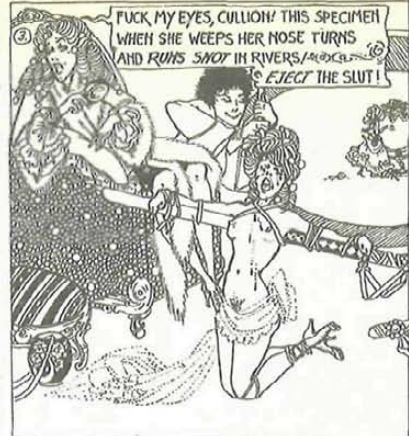

12  
 Ah, the scandal! Will Count Gilbert, cursed with a pedigree barely two generations old, ever succeed in storming the bastions of Society?  
 Attend, yours the next episode!

## Glory of their Hindsight

continued from page 62

Rube would eventually clam up and then start pushing and griping at the man ahead.

One time, it must have been May of 1902 on the way home to St. Louis after a bad series with Washington, it was real early on a Sunday morning someplace near the Cumberland Gap, and we were following the railway tracks. A cold, gray morning, too, chill as the grave. Well, along comes this train and I don't know, guess we were all just whipped, but first one guy and then another and pretty soon everybody's crying. Fifteen grown men, Major League ballplayers, setting beside the railway tracks crying their eyes out while the train goes by.

But let me say just so there's no misunderstanding about this, those were swell times, the swellest of all. You had to take the bad with the good if you wanted to be a Major League ballplayer...and you did. Took the bad with the good. Being a Major League ballplayer...what a privilege!

## 5 Ebos Depew

I'd rather have fingers than toes,  
I'd rather have eyes than a nose,  
And as for my hair, I'm glad it's all there,  
I'll be awfully sad when it goes.

—Gelett Burgess

They called it the wee-wee ball or the groinball in the papers and in public, but we ballplayers called it the plain old pissball because that's just exactly what it was, nothing more, nothing less. Old Ebos here has to take credit for inventing it and I will. Threw it from 1916 to 1921 and it got me into the Hall of Fame rest room. No, that last was a joke. But how I came to throwing the pissball, that wasn't no joke. At the time in fact I was dead serious and scared out of my wits, not that a seventeen-year-old rookie pitcher has many wits to be scared out of!

Well, this was the season of 1916 and I was just up to the Washington club from Murfreesboro down in the Golly League, Big jump to make, but I'd won me something like 400 straight games, most of them no-hitters. Had me a fogball, I called it. Seemed to come out of a fog, it was so fast. Truth was, I never even threw the darn thing, catcher just made this loud "Plop!" in his mitt. Dumb bunch of farmboys in that Golly League... dumb! But of course they wouldn't go

for that up in the American League and here I was, rookie phenom and all, and who do they decide to pitch me against in my first start but the Cleveland club! Now that was some ball club. They had Kaiser Bill Brummel, Ozzie Furbelow, big Cube Razzle on first, and, of course, Chief Wampus, and they were just tearing up the American League that summer.

This was in Washington in the old Federal Stadium, must have been ten or eleven thousand people come out to see the rookie sensation. President Wilson even come out. Shook my hand before the game. Tried shaking hands with Chief Wampus, but the old Chief chased him off with a bench, a bat, something like that. Chief Wampus, there was a discourteous man if ever one lived!

Well, now I'm in an awful fix and it's about to get worse. First man up, little Bruce McSunnyworth, the short-stop, lines a single. Next man lights into my first pitch, another single. By now I'm so nervous I don't know which way's home plate and I walk Kaiser Bill on four pitches. Bases loaded. Nobody out. Crowd's turning real mean, real fast. Had my mom in the stands and they start to roughing her up, a kind of warning. Chief Wampus was batting cleanup for Cleveland and now he's in the batter's box and almost cracking a smile. Oh, he could just hardly wait to cream the kid! I'm afraid to pitch to the Chief and just as scared of being called a quitter, and there's Mom going down out of sight in the stands again. Next thing I remember is feeling something warm down on my pants legs. Yep, wet myself. Peed my pants.

Well, that was the luckiest damn thing ever happened to old Ebos Depew, because with my motion, holding the ball down on the knee before the big kick, some of the piss gets smeared on it. Never saw an emory ball or a spitter or anything move like that pissball. Wiped the grin off Chief Wampus's face. No-hit those bastards the rest of the game.

Later on, of course, I got mighty cute. Cut a slit in my pants and just gave a little squirt on the seams. That took off some of the speed, but it gave a hop and a bump nobody could hit.

But the real secret I'm going to tell now for the first time. It was all in the chemical content of the urine. The piss. The reason so many of the boys tried the pissball and it didn't work was their urine content. Gin, beer, water—no good. You needed an exact

mixture, 60 percent bay rum, 40 percent buttermilk. God, I had a hard time getting that stuff down.

You'll find in the record book I never won another game after the 1921 season. Pumping gas by the summer of '22. Prohibition come in and no more rum. No more pissball. No more Ebos Depew.

But gee, it was great while it lasted!

## 6 Yahoo Bill Blazes

His blood hath run in peasant veins  
Through many a noteless year;  
Yet, search in every prince's court,  
You'll rarely find his peer.  
For he's one of Nature's Gentlemen,  
The best of every time.

—William James Linton

Just a few years back down in Florida, I ran into this old geezer, a man my own age with a squashed-up face like some circus freak. Looked familiar, though, and of course it was Dog-Face Huckstep. "You're the only human being ever looked like that!" I says, even if I hadn't seen Dog-Face since 1919 when I was pitching and he was catching for the Philadelphia club. You could never forget that kisser in a million years!

Now if anybody had a right to complain about a bad shake in life, it was Dog-Face. Played for years before he knew a catcher was allowed to wear a mask, so his face took an awful pasting. He didn't have what you could call a real nose left...that's how come he was Dog-Face, all mashed in like it was, like a pug or a bulldog.

Well, Dog-Face and I naturally took to reminiscing over old times and I'll never forget this, he said with that squeaky little voice—you had a hard time hearing exactly what Dog-Face said, the way his nose and mouth were laid out—he said, "Yahoo, now those were the most wonderful times and I never regretted one single minute of it." He was crying.

Now, that what Dog-Face said I'm not quoting exact. But I'm sure it was something like it. Mighty close, anyhow. You'll get the same story from anybody. Just a grand, grand time to be in the Major Leagues playing ball.

## 7 Killjoy Fomeen

As I was going up the stair  
I met a man who wasn't there,  
He wasn't there again today.  
I wish, I wish he'd stay away.

—Hughes Mearns  
continued

## Glory of their Hindsight

continued

I'm sick and tired of all the jokes about those old uniforms with the thick flannel and long sleeves and little soft collars. They was our pajamas. Wear *your* pajamas, see how you like it. No choice back in 1908, who had the money for a uniform? Had to pay admittance to the games we played in. Never saw *that* wrote up in all the crap and claptrap they write about the old days. Or Mr. Comiskey paying us off in play money. Seems Five-Finger Cudahay talked about that and he treated it very funny. Very light. Well, he might of done me the favor of letting *me* in on how Comiskey was paying us in play money. How was I to know? Come from a farm down Missouri way. Never saw real money before.

Hated playing on the Chicago club. Hated most when we changed over to the nickname, White Sox. Not afraid to tell that one, either. This was 1909 and baseball was still a rough-and-

ready game in people's minds. They just saw a bunch of rowdies running around in dirty pajamas, when the truth was we couldn't afford uniforms. Nobody wore socks, either. Couldn't afford 'em. Comiskey, oh, there was a sly old bastard so cheap he squeaked, always looking for another nickle somewhere. I think he saw a way to increase the home gate if his club didn't look so raggedy and bare-legged. Draw the family trade, the ladies and the like. Well, that was his business. He comes over to the rooming house where we stayed on the South Side and gets us all in the parlor and he announces it. "Now, boy," he says—had a real oily manner—"now boys, from today on you're gonna be the Chicago White Sox." Well, of course, we all thought we were getting socks. Ha! Comiskey just takes out this little ten-cent can of talcum powder. "Now boys," he says, "before every game, what I want you to do is wash up your legs and roll your pants up to

the knee and sprinkle some talcum powder on and rub it in. We'll have a grand old time fooling the public!"

What he was after was *fleeing* the public. They was the same bunch of baboons on that Chicago club with or without their legs all powdered up, but from the stands they looked like real swells and that was his plan. Wonder what he'd of done if any of his players had been a colored?

Don't know which was the bigger lie, calling that bunch of roughnecks the Intelli-Gents or calling them the White Sox. Sure I went along with it, Comiskey owed me \$3 million and I couldn't risk ticking him off and getting traded away before I collected. I did collect. Goddamn play money. Three million dollars in play money. Very funny.

But, oh, how I loved playing that game. Those was glorious days. What I wouldn't give to have them over. Say what you want, it was a thrill to be in the Major Leagues. Thrill of a lifetime, I'd have to say. □

## Valley High

continued from page 57

children and I guess he's right because I've never dated any of those guys. Mr. Slumbach said he didn't know what the heck the Concerned Parents were talking about and observed that "some people are nuts." Well, he had just gotten over that when the Ellis brothers dropped out of school and joined the Reverend Moon church. (Their parents are trying to get them deprogrammed and everything, but even if they do, they'll probably be ineligible because of flunking.) Then Johnny Hartman wouldn't wear regular football shoes because they were made out of animals and Randy Lockerwood, our star quarterback, began to become some kind of Buddhist and wouldn't use anything but some huge long chant for his play signals:

*Nam myoho rengo kyo  
Nam myoho rengo kyo  
Nam myoho rengo kyo  
Nam myoho rengo kyo  
Nam myoho rengo kyo  
Nam myoho rengo kyo  
Nam myoho rengo hiki*

Which cost us a five-yard penalty for delay of game during the game with Mad Anthony Wayne High, not to mention the meditating in the huddle. And between all that and some of the other guys who decided out of the blue that football wasn't "where it's at" or "with it" or what they were

"into," Coach Slumbach only had two squads left with three games to go yet. And two of them against undefeated Cardinal Pitsky and undefeated Marcus Garvey.

Poor Coach Slumbach! Valvoelen Cleveland, who's a Badgerette, did the "Cheer-Up" shout:

*Badgers, Badgers, don't be blue!  
We've got lots of faith in you!  
We're sure as heck you'll win  
just fine  
Even though you're [blank  
where we put in the number  
of points we're losing by]  
behind!*

and some tumbling in the aisle to cheer him up. She's Negro but her dad has a lot of money. Also her brother is an end. But, truthfully, we weren't all that worried because the only game we'd lost so far was to Nikolai Tesla Tech and they'd been disqualified for the 1975-1976 season because their fullback turned out to be twenty-four and an ex-convict. We'd beaten Riverbed High and John Stuart Mill, not to mention the Mad Anthony Wayne Musketeers, who are pretty good even if it was by only a kind of a freak safety we made when "Flaky" Albertson fumbled in the end zone. But nonetheless we were optimistic in our thoughts that Valley High's the greatest, and besides, we were awful late to the Ice Ball theme and decorations committee meeting.

## II. A Meeting of the Ice Ball Theme and Decorations Committee Which Makes Us Feel Almost as Lcky as the Coach

All the guys on the committee were already there when we got to the Senior Soft Drink Lounge. Especially "Flaky" Albertson and Randy Lockerwood and Valvoelen's brother Grover and Jimmy Duncan, who plays the other end, and Johnny Hartman, the right tackle, and "Brick" Lombard, our center, who together with Jack Shinn and Bob Chumley makes up our famous "Three Donkeys" offensive middle of the line. Shrimp Hargis, the team waterperson, was also there. "We've got it all figured out!" they yelled as we came in the door. They were all excited. "This year's theme will be 'Sex and Disease'!" they yelled.

"We'll decorate the lunchroom with leather and surgical supplies!" said "Flaky" Albertson, "and we can get Dorian and the Dinky Toys to play for only \$200. They dress up like women in rubber scuba suits and they have this one part in their act where they put plastic tumors on their bodies and sing 'My Love for You Is Growing Like Cancer'!"

"Randy and I wanted not to have a band at all," said Johnny Hartman, "and have a sock hop instead and donate all the records to the people in Bangladesh when it was over. But

continued on page 91

# NewTimes for half price.

## That's like getting every other issue free.

### It's quite a deal.

The regular price for a year's subscription to NEW TIMES is \$15.

Subscribe here and now and you can have a year (26 issues) for only \$7.50. Half price. And a lot less than half price compared with the \$19.50 you'd have to pay at newsstands.

How come? Why are we letting you have the magazine for so little money?

Because we want to get NEW TIMES into your hands. Frankly, we think you'll be hooked.



### The freshest news magazine since Time began.

After NEW TIMES, other magazines are going to seem pretty mild. Newsweek said, "The magazine has shown a particular knack for picking up on hot stories that others tend to drop after the first flash." The Los Angeles Times called us "brash, irreverent and surprisingly literate."

William Safire in the New York Times says we're "the magazine that has an adversary relationship with the world." According to the Washington Post, we're "a new national news magazine of storytellers." To good old



Time Magazine, we're "impetuous."

So be it. NEW TIMES makes things happen. We aren't afraid to tell all the truth we can get our hands on. We turn over rocks. We make waves. Troublemakers? You're damn right.

### Remember folks, you saw it first . . .

A lot of NEW TIMES stories were firsts. Newsbeats. Scoops. Sure you read about them in other magazines. Afterwards.

We were the first national magazine to reveal the link between the CIA and the Mafia. We were the first to go underground and interview Abbie Hoffman. (Among those who wondered how we found him—the FBI.)



The new wave of doubt about the JFK assassination started in NEW TIMES, with stories like the one that showed there had to be several Oswalds. We were the first national magazine to tell the world that those little aerosol cans could be the death of us all. We put est (Erhard Seminars Training) in the public eye. We reported the murder trials of Peter Reilly and Joan Little long before they hit the front pages. And so it goes.

### What's happening around here?

NEW TIMES, more than any other magazine, is plugged into now. It's the magazine of what's happening, and that's a spectrum that includes love and music and lifestyles and all manner of rare new ideas.

We investigated the medical benefits of marijuana . . . tried to make sense of the Psychobabble that's drowning us all . . . dissected the Great American Bicentennial Sale . . . dug into the yearly orgiastic revels of a



country fair . . . looked into what happens when single grandparents are forced to live in sin to avoid losing their pensions . . . ran the first-anywhere story on doctors who sell their patients to hospitals for kickbacks . . . found the real Mr. Goodbar of the singles' bar murders.

And of course, in every issue we're catching rock, movies, books, fads, and fatuities with the kind of brash, fresh viewpoint you aren't going to find in the other magazines.

If you really care what's happening in America in 1976, you're going to get into NEW TIMES.

And the lucky thing is, if you act fast you can get into it for half price. Just use the attached card. Or call us toll free anytime of the day or night. (800) 327-8912.

6218

**NewTimes**  
The Feature News Magazine

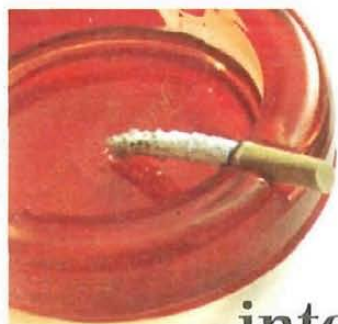

You work hard when you're recording. It takes time and concentration. And a tape about to run out usually means stopping to

interchange reels, rethread, and generally get the feeling that you're starting all over again. The 4070G lets you keep on recording because it records and plays in both



directions. With full monitoring capabilities. And for the

times when music makes the mood, the automatic repeat function lets you enjoy a favorite tape for as long as you like. The 4070G.



You won't have to worry about running out of tape right in the middle. Just press the button and keep on recording.



reverse the machine, not the tape.



**TEAC 4070G**

The leader. Always has been.

TEAC Corporation of America 7733 Telegraph Road, Montebello, Ca. 90640 ©TEAC 1976

Just call (800) 447-4700 or (800) 322-4400 in Illinois, toll free, for the name of your nearest TEAC retailer. He'll be happy to show you the 4070G in action.



April 1, 1976

Clarence Campbell, President  
National Hockey League  
2 Penn Plaza  
New York, N.Y.

Clarie Baby,

Enclosed is our bill for \$1,000,000 (less our \$50,000 advance) as per our agreement, and our recommendations for putting the great game of hockey back on network TV in the U.S.A., where it belongs.

Nutshelling our brainstorming, hockey and all mass media pro games are still based on outmoded, linear, pre-global village concepts of GEOGRAPHICAL identification and hometown fan loyalty. But in our fluid, mobile society, no one lives in any one place long enough to empathize with a team representing that place. (Who gives a fuck about the Kansas City Scouts? Nobody lives in KC, for chrissake!)

Team ID and spectator empathy must now be based on the image of the team ... it's iconography. (This has worked before, in other sports. Every bum in the country was a Dodgers fan, blue collar morons feel NFL Steelers to be an extension of themselves, etc., etc.)

We think-tanked through the concept that NHL teams must assume the identities, qualities, personalities (ethnic, sexual, political) of the U.S.A.'s fanatical minorities - the Pittsburgh Papists, Toronto Tin Horns, Minnesota Masochists, etc...if hockey is to seize its share of the market.

We turned a world-famous hockey illustrator loose to sketch out possibilities. And we think we've got a winner! In anticipation of your check and your success, we remain



Marshal Alvin



California Golden Seals should key on carefully cultivated endangered species image. Appeal to salad crazed California eco-maniacs as the Oakland Organics. Hand-whittled sticks, bio-degradable pucks, etc.

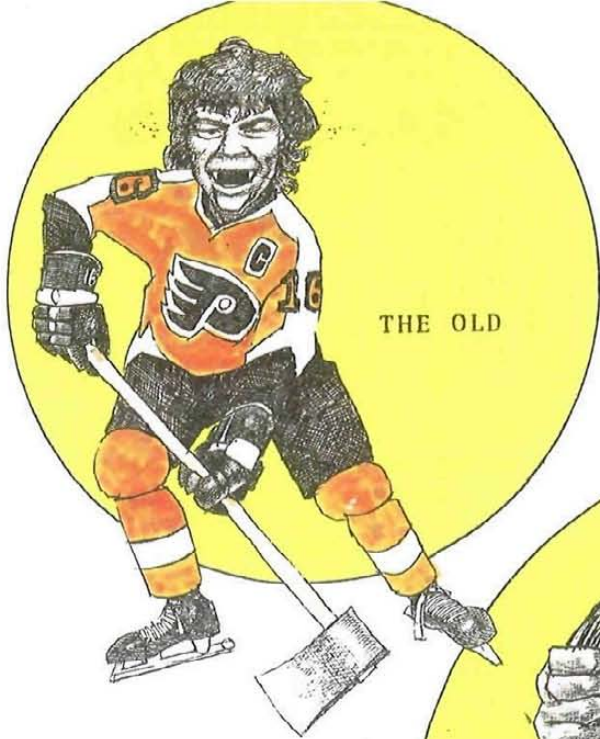

THE OLD

Philadelphia's image needs only slight upgrading. Keep toughness, add sex appeal. Surveys show women eat up violence. An all-female team. Broad Street Bull Dykes? Philadelphia Fillies?



THE NEW

DROP YOUR PANTS, BRUCE



THE OLD

Boston's image: effete, East Coast. Rebuild around cutest defencemen in league, Park and Orr. (Refer to Esposito's departure to N.Y. as a "rough trade.") Re-dub Hub squad Gay Blades, appeal to homos' well known fondness for blood sports.

HERE COMES THE GLASS' ASSHOLE!

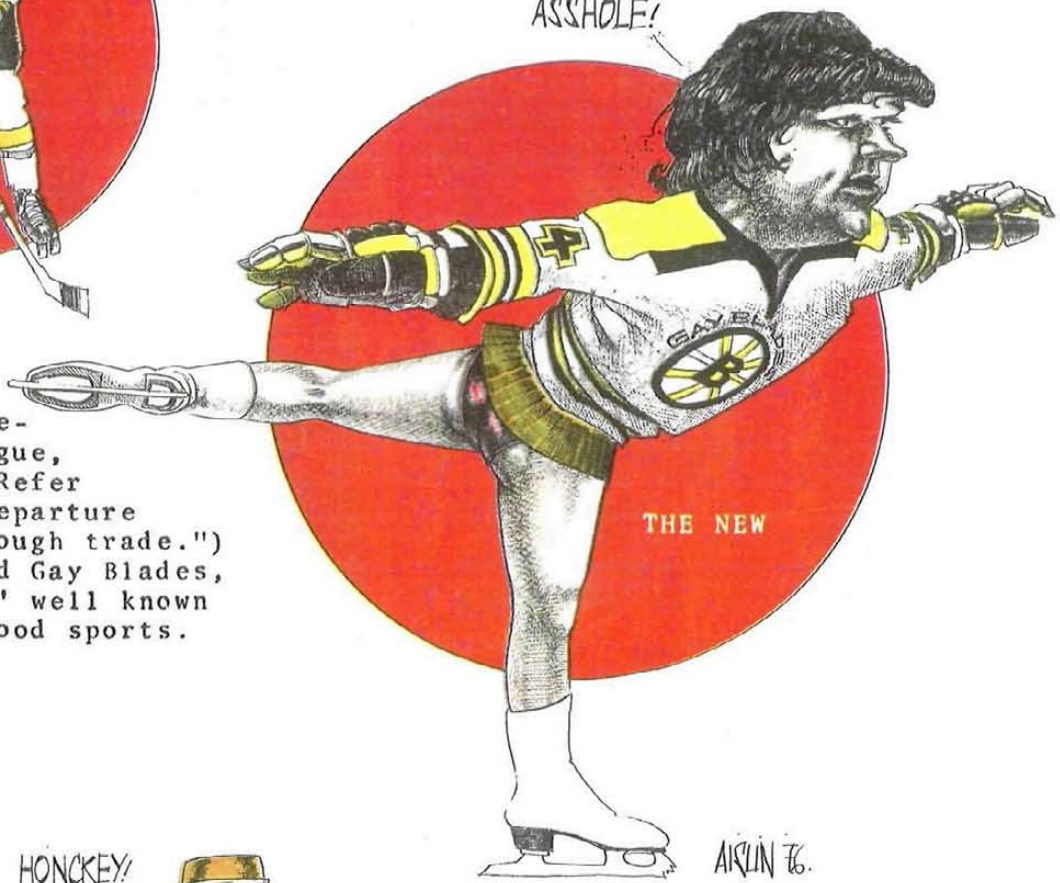

THE NEW

AISLIN '76.

HONCKEY!



THE OLD

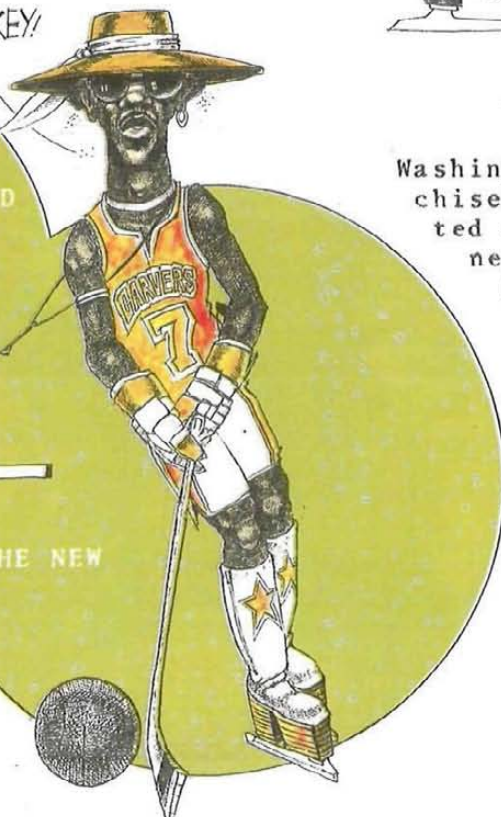

THE NEW

Washington's failing franchise must be reconstructed around sole existing negro player in NHL. Retitled Washington Carvers, should appeal to usual blacksploitation morons. Slogan: "Soul on Ice."

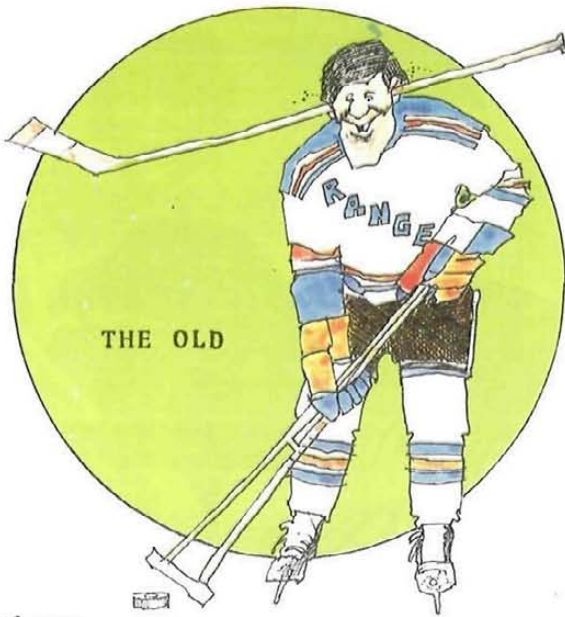

THE OLD

Hapless Rangers must rebuild around Espo's greaser image. An Italo-American club should appeal to Manhattan's major business interests. Retain as coach Ferguson, ex-Montreal hit man.

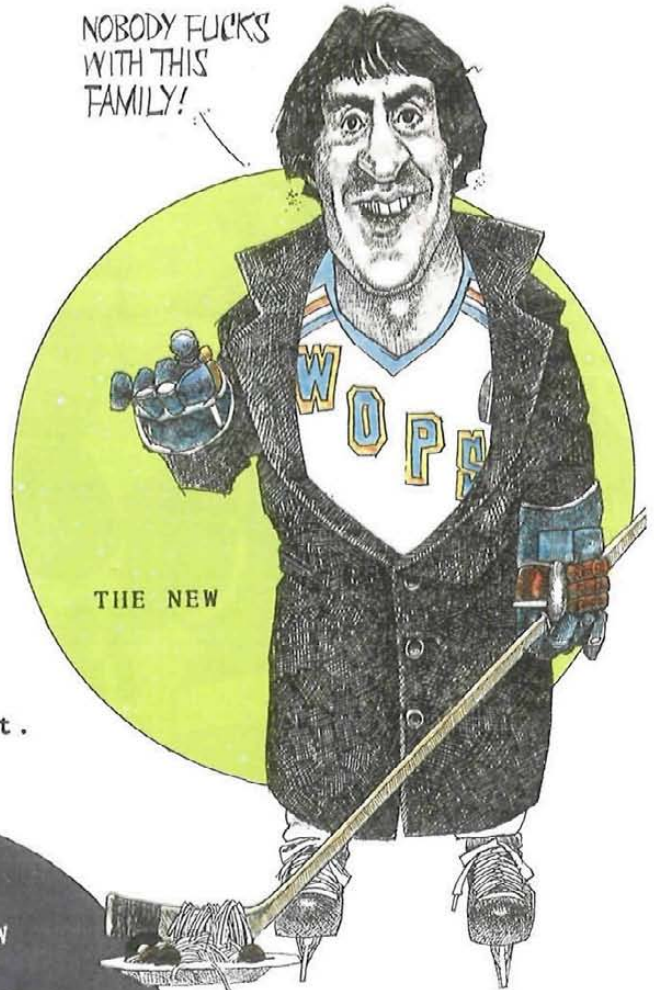

THE NEW

Across town, the Islanders must become the Long Island Liberals, and lose constantly to satisfy the community's collective sense of guilt. Their games against the Washington Carvers are guaranteed to outdraw Superbowl and "Upstairs, Downstairs" combined.

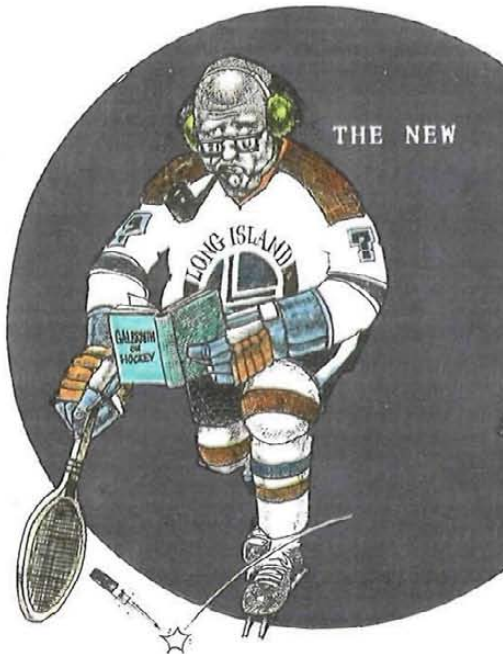

THE NEW

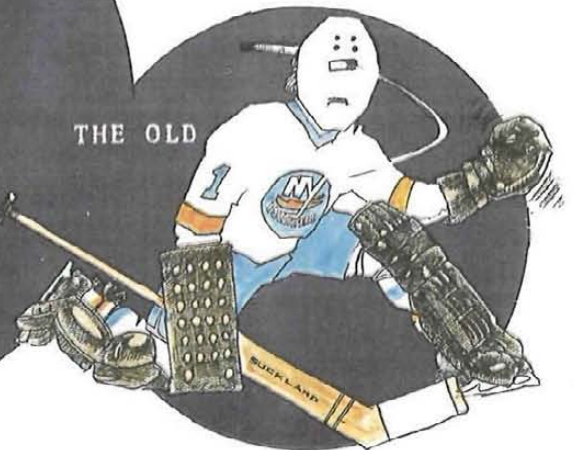

THE OLD

# BOOK AND RECORD BARGAINS

**514028. MAXFIELD PARRISH POSTER BOOK.** Introduction by Maurice Sendak. Posters suitable for framing from the major periods of an artist known for his luminous colors, nymphlike forms, and the romance, flamboyance, and sensuality of his work. 11 1/4" x 16". 48 pages. 24 posters in full color. Only \$5.95



**520435. POSTERS OF MUCHA.** 24 Posters in rich Full Color. The flowing, sensuous designs of Alphonse Mucha, one of the prime exponents of Art Nouveau, collected in a deluxe, large-format (11 1/4" x 15 1/4") book. Includes the famous posters of "The Divine Sarah" Bernhardt; the Job cigarette poster and other Current favorites, and many never before published in America. Softbound.

Only \$5.95

**16826X. EROTIC MOVIES.** By R. Wortley. Over 200 Photos. Brilliant photos, many of them rare and all uncensored, trace the history of eroticism in the movies from the first screen kiss in 1896 through today's uninhibited and totally explicit films, incl. Bardot, Monroe, Redford, Deep Throat, Emmanuelle, Jane Russell, Hedy Lamarr, much more. For Sale to Adults Over 21 Only.

Extra Value Import Only \$4.98

**900009. THE GOLDEN AGE OF COMEDY.** 20 of the funniest routines ever performed: Abbot & Costello's "Who's On First," Groucho Marx in "You Bet Your Life," Jack Benny's "The Holdup," "Your money or your life!" — The Mad Russian, Sid Caesar & Imogene Coca, Burns & Allen, Milton Berle, Ed Wynn, Jackie Gleason, Ernie Kovacs, many more. Pub. at \$9.96 2 Record Set Complete. Only \$5.99

**177471. EROS IN POMPEII:**

The Secret Rooms at the National Museum. By M. Grant. 159 Full Color Photos. A phenomenal vol. presenting the most famous erotic wall paintings, mosaics, statues and household objects in the National Museum at Naples, access to which is still restricted. Presented for the first time in book form, these objects were photographed in full color and depict every type of sexual activity imaginable. 9 1/2" x 11 1/2". For Sale to Adults Over 21 Only.



To Be Pub. at \$20.00 For Limited Time Only \$14.95

**060884. SWAP CLUBS: A Study in Contemporary Sexual Mores.** By W. L. Braedlow. Authoritative account including detailed case histories of married and single swap club members, initiation rites, perversions, etc. Plus glossary of sexual terms. Pub. at \$5.95

Only \$2.98

**169991. RAPTURE.** 13 Erotic Fantasies. 154 Photos by R. Raffaelli. Perhaps the most spectacularly photographed book of its kind, these totally uncensored photos reveal the unlimited possibilities of two — and sometimes more — people letting their sexual fantasy turn into sexual reality, incl. foreplay, intercourse, masturbation, group sex, more. 8 1/2" x 11". For Sale to Adults Over 21 Only.

Only \$20.00

**171996. THE FULL COLOR GUIDE TO SEXUAL PLEASURES FROM A TO Z.** By G. Hunold. 125 Full Color Photos. First English translation of the European bestseller that in frank, candid language and explicit photos, deals entirely with giving and receiving sexual pleasure, incl. stimulants, positions, prolonging intercourse, sodomy and masochism, swapping, incest, more. Softbound. For Sale To Adults Over 21 Only.

Only \$7.95

**144352. THE PIN-UP: A MODEST HISTORY.** By Mark Gabor. Hundreds of revealing photos, 53 full-color plates. Erotic and tantalizing look into the fantasy world of pin-ups, incl. homosexuality, bondage, nudity, fetishes, girlie magazines, sex goddesses and gods of the silver screen, lots more. Orig. Pub. at \$20.00

New complete ed. Only \$7.98

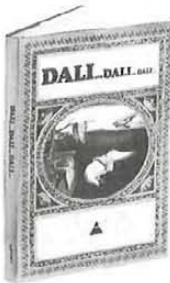

**177927. DALI, DALI, DALI.** By M. Gerard. 98 illus. The flamboyant madness of Dali is dramatically captured in this extremely handsome kaleidoscopic vol. containing his ideas, designs and works on a wide variety of topics from cannibalism to eroticism to mysticism. Also incl. biography as well as an introduction by Dali's analyst. Orig. \$15.00

Now Only \$7.98

**524163. CUT: The Unseen Cinema.** By B. Phillips. 260 illus., 4 Full Color Pages. Even with today's relaxed standards, certain scenes or whole movies never make it past the censors. Profusely illus. with stills from these overtly sexual and violent movies, this vol. explores what has been missed by the public. Including Deep Throat, The Devils, The Night Porter, Rachel Welch's The Wild Party, more. For sale to adults over 21 only.

Only \$3.98

**SPECIAL OFFER:** With any order totalling more than \$10.00, you get a free copy of this fantastic, Full Color, NATIONAL LAMPOON 199TH U.S.A. BIRTHDAY BOOK, the greatest satire and parody on American history ever created. Regular Price: \$2.95



**139901. SEXUAL INTIMACY.** By A. Greeley. How to radiate an aura of sexual attractiveness so that your wildest fantasies can be realized. Candid advice for potential sexual partners to enjoy playfulness and variety in any type of relationship. Pub. at \$6.95

Only \$1.98

**105500. ENCYCLOPEDIA OF LOVE AND SEX.** With 265 vivid illus., 173 in full color. Incredibly comprehensive, pictorial guide to every aspect of lovemaking: 66 explicit chapters on positions for loving, oral sex in love play, group sex, fetishes, male and female orgasm, masturbation and fantasy, genital size, homosexuality, etc. 8 1/2" x 11 1/2". For sale to adults over 21 only.

Only \$10.95

**145502. THE COMPLETE IMMORTALIA.** Ed. by Harold H. Hart. Drawings by Lindi. An especially choice compendium of the lewd, Ribald and outrageously funny, these folk songs, sea shanties, college songs and nightclub ditties have been sung for generations and there is nothing suggestive about them. Melodies in musical notation and guitar chords are included. For Sale to Adults Over 21 Only.

Orig. Pub. at \$12.50 New complete ed. Only \$3.98

**524228. SAVAGE CINEMA.** By R. T. Witcombe. 250 illus., 4 Full Color Pages. Bites deep into the scale of 20th century violence in the cinema and explores through copious illus. the theme as present in western and horror films, the worlds of Hitchcock and Polanski and a thorough analysis of Stanley Kubrick's Clockwork Orange.

Only \$3.98



**931680. THREE HOURS FIFTY NINE MINUTES FIFTY ONE SECONDS WITH THE MARX BROTHERS.** Zany, raucous, hilarious collection of 25 radio programs. Hear the Marx Bros. cavort, carry-on, destroy and perform with Bing Crosby, Tallulah Bankhead, Fanny Brice, Mel Tormé at age 17, Lucille Ball, Jack Benny, Johnny Weissmuller, Dinah Shore, Harry Von Zell, Al Jolson, Oscar Levant, plus Harpo's first-time-over interview! Due to the age of these broadcasts a certain amount of surface noise will be noticeable. \$25.00 Value 4 Record Set Complete. Only \$9.95

**520451. THE BEATLES: A RECORD.** By Roy Carr and Tony Tyler. 250 Photos, 90 in Full Color. The most thorough coverage of the Beatles to date, featuring a critical record-by-record study of all their releases, including the famous bootlegs, biographical facts, and a career diary. Sections include The Early Years, Beatlemania, The Studio Years, and The Solo Years. Softbound.



Only \$6.95



**523507. HEAVENLY BODIES.** The Complete Pirelli Calendar Book. Introduction by David Niven. 120 full color photographs — 120 perfect fantasies — of at least 200 beautiful women in the most beautiful settings imaginable. All the Pirelli calendar beauties from 1964 to 1974. 8 1/4" x 11 1/2". 304 pages. Illustrated. Only \$9.95



**515784. MORE JOY (OF SEX).** Ed. by Alex Comfort, M.B. Ph.D. 224 illus., 32 in Full Color. Handsomely illus. by the same fine artists, More Joy begins where The Joy of Sex left off! Covers the entire spectrum of the sexual revolution — one-to-one, bisexuality, a positive yet cautious exploration of sex with more than one partner from threesomes to couples and others; hostility and bondage, problems of the elderly and disabled, contemporary sex therapy, and a general celebration of sex-as-fun. The Rolls-Royce of sex books. Chicago Tribune Book World. Pub. at \$12.95

Only \$6.98

## MAIL THIS COUPON TODAY!!

21ST CENTURY BOOKS, Dept. NL476  
635 Madison Ave., New York, N.Y. 10022

Please send me the book and record bargains circled below. MINIMUM ORDER \$3.

On orders totalling \$3 to \$10, add 60¢ per title for shipping charges.

On orders over \$10, no charge for shipping. Add 75¢ per title for deliveries outside continental U.S.

Enclosed find \$\_\_\_\_\_. Send check or money order only. Payable to 21st Century Books.

Sales Tax: For delivery in N.Y.C., add 8%. For delivery elsewhere in New York State, add 6%.

514028	060884	177927	524228
520435	169991	524163	931680
16826X	171996	139901	520451
900009	16292X	105500	523507
177471	144352	145502	515784

Name \_\_\_\_\_

Address \_\_\_\_\_

City \_\_\_\_\_ State \_\_\_\_\_ Zip \_\_\_\_\_

# The All-New National Lampoon Iron On Book

to decorate T-shirts, tank tops, or Grandma's favorite sofa.

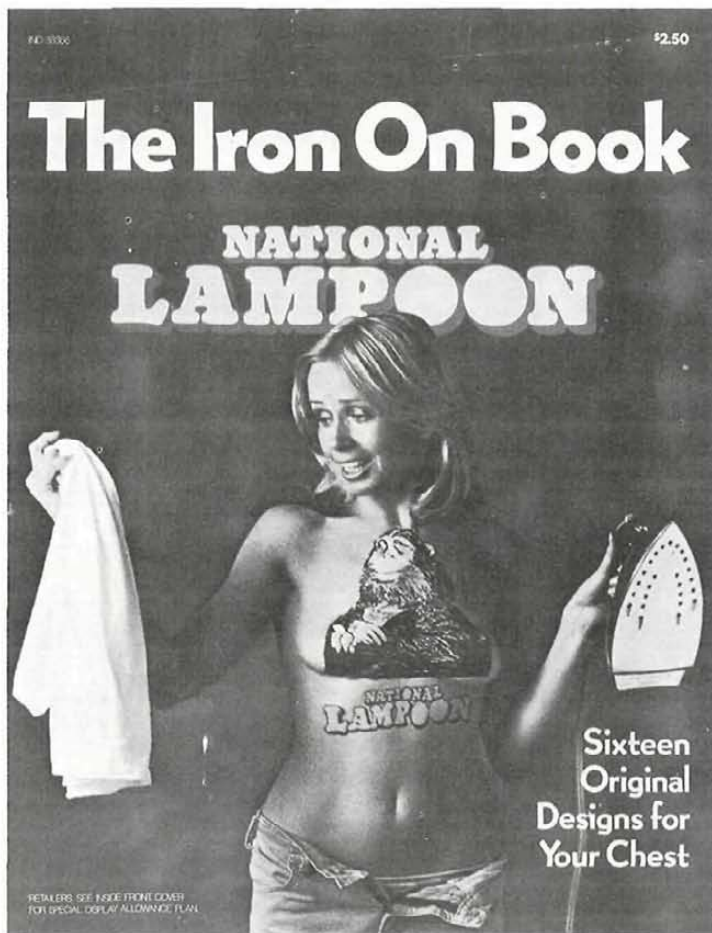

Sixteen creations from those swell folks at NatLampCo,  
the company that will sell you anything.

Iron-ons include political put-downs, purely artistic designs in the **National Lampoon** fashion, and other full-color art and words and miscellanea that have never before been seen in the short but fascinating history of the T-shirt.

These heat-transfer designs would ordinarily sell at stores everywhere for \$1.00 each instead of 16 for \$2.50, but **National Lampoon** designs are not available at stores anywhere.

The **National Lampoon Iron On Book** is distributed in bookstores and on newsstands on a limited basis and may not be available in your area. If not, you can order it by filling out this coupon and enclosing a check or money order with it.

Sixteen original **National Lampoon** iron on designs, mostly in full color—\$2.50.

The National Lampoon, Dept. NL476  
635 Madison Avenue  
New York, New York 10022

Check       Money Order

Please send me \_\_\_\_\_ copy(s) of **National Lampoon's Iron On Book** at \$2.50 per copy.

Name \_\_\_\_\_  
(please print)

Address \_\_\_\_\_

City \_\_\_\_\_ State \_\_\_\_\_ Zip \_\_\_\_\_

Please make sure to list your correct zip code number.

All checks must be payable within continental U.S. or Canada.



## Valley High

continued from page 57

we like this idea, too."

"What about the Jock-Tones, like we had last year?" all of us asked them. The Jock-Tones are really good. They play a lot of oldies and at the end of the Ice Ball last year they played our school Loyalty Song that's to the tune of a number in "South Pacific":

*Valley High will call you  
Any night, any day  
In your heart, you'll hear it call  
you,  
Win the game, hurray, hurray!*

*Your own special hopes  
Your own special dreams  
Will bloom between the goal-  
posts*

*As you root for its teams  
Valley High, Valley High,  
Valley High!*

Plus they are \$75 cheaper.

"The Jock-Tones are a drag," said Jimmy Duncan. And to think that I was in love with him for three months last year. Then he started wearing platform shoes and began walking into furniture. At first I thought it was the shoes, but now I think he's been abusing downers.

"The Dinky Toys are a real glitter band," said "Flaky," "just like in New York. They were the act after the opening act at the Z.Z. Top concert in Bengal Stadium the year before last and they're going to have a record pretty soon."

By now, we girls were beginning to think Coach Slumbach had a point.

### III. A Bad Week

Tuesday the janitor caught Randy Lockerwood planting lima beans in the end zone during study hall. Randy said that it was bad ecology to waste land space on regular grass and that lima beans were a great source of protein. Peg Entwhistle, who used to be Randy's girl friend before he started to go goofy last summer, tried to point out to him that the lima beans he was planting might be a great source of protein but they had also already been cooked. But Randy didn't want to hear about it and he and Johnny Hartman and Tommy Sieler and Dick Werner, who are the rest of the first-string backfield, decided to have a fast for the rest of the week during which they would only drink lima bean juice to prove Randy's point. *Ick*. Randy also got three detention periods for leaving the building without a hall

pass and he would have been in a lot more trouble than that over the fifty cans of stolen lima beans if Peg and I hadn't done some fast talking to Mrs. Myrtle in the cafeteria.

Wednesday the entire team showed up for practice with glitter glued all over their helmets and those no-glare smudges on their eyelids instead of their cheekbones, not to mention some rouge and other makeup. Coach Slumbach was furious! He made them all go in and wash their faces and come back and roll their heads around in the mud until nothing sparkled and then made them run up and down the stadium stairs all afternoon. But Jimmy Duncan had tried to make some negative-heel football spikes by drilling holes in his earth shoes and he kept falling over backward so hard that he started making airplane noises and Coach Slumbach made him sit down in the bleachers. I'll bet "Flaky" Albertson was behind all this. I made Shrimp Hargis check up on it and there was an extra lot of glitter in "Flaky's" shoulder pads and six empty bottles of Elmer's Glue-All on top of his locker, and even I know that the only thing you get if you sniff Elmer's is a sticky nose.

Thursday most of what was left of the second string told Coach Slumbach that they had started a Second String Liberation Front. They said that the second string of a football team had historically been discriminated against and told that they were not as good as the first string. Most second stringers, they said, had been in the past unwilling to confront their second stringness and had instead just attempted to be like first stringers, accepting the idea that the first string was better than the second string. But these second stringers, they said, meaning themselves, were "coming out of the locker room" to fight for "Stringual Equality," and since second strings are equal with first strings according to the Constitution, they wanted to be on the first string. Mr. Slumbach cut, that is to say fired, them all on the spot, even though the big game with Cardinal Pitsky was only two days away.

By Friday Coach Slumbach had given up even pretending that he was walking into the girls' locker room by accident after Honors Pep Gym, although he did knock first, and he looked ickier than ever.

"'Brick' Lombard thinks he's going to Venus," he sighed dismally.

"Huh?" we all said.

"'Brick' Lombard met some people who said they were from another planet in the shopping center yesterday and now he and Jack Shinn and Bob Chumley are sitting outside in his car waiting to go to Venus with them. 'Brick' gave away his stereo and they've got about a hundred Big Macs in there and they say they're not budging from the school parking lot except to go to the bathroom until the saucer arrives."

Now we really had a problem, what with only a couple members of the second string left and the "Three Donkeys" sitting in the parking lot and Randy and Tommy and Johnny and Dick not eating anything but lima bean juice all week and Jimmy Duncan still making airplane noises off and on, especially in civics class, and only twenty-four hours until kickoff against the large and very well-coordinated Cardinal Pitsky Penguins. We still hadn't figured out what to do about that awful idea for the Ice Ball, either. Dorian and the Dinky Toys—how gross! But that would just have to wait. At the moment, football was *everything!*

Then Bobbi Duckworth figured out a plan. Bobbi is a very sophisticated type when she wants to be. Her father owns the largest trucking company in the tri-state region and she hangs out with sophomores at the University of Cincinnati and tries marijuana all the time. Some of the girls think she's *too* sophisticated, especially after they heard her plan idea, but it was the only plan we had so Honors Pep Gym swung into action.

### IV. Honors Pep Gym Swings Into Action

There was myself and the rest of the cheerleaders and Valvoleen Cleveland and the other Badgerettes plus the Entwhistle twins, Peg and Patsy, and Bobbi Duckworth and my very best friend Dilly Hutchinson who, although she has a small weight difficulty, is very well built in some places. Patsy Entwhistle wasn't too hot on the idea, but Peg told her not to be hokey-pokey and besides even if they were Catholic it wasn't like we were going to marry them or anything like that.

So that evening after supper we all quickly drove over to Tad's Burger

continued



# Collector's Items



**OCTOBER, 1971/BACK TO SCHOOL:** With the *Mad* parody, Rodrigues' Hire the Handicapped, Magical Misery Tour, The Campus War Game, School of Hard Sell, and 125th Street.

**DECEMBER, 1971/CHRISTMAS:** With Jessica Christ, Blind-Date Comics, This Is Your Life... Francis Gary Powers, The Russian Gift Catalogue, and Editorial Fantasies.

**MARCH, 1972/ESCAPE!** With Hitler in Paradise, the California Supplement, celebrity suicide notes, the *Papillon* parody, Swan Song of the Open Road, and doing it with dolphins.

**APRIL, 1972/25TH ANNIVERSARY:** With the '58 Bulgemobiles, The Playboy Fallout Shelter, Commie Plot Comics, Frontline Dentists, Third Base, the Dating Newspaper, and Amos 'n' Andy.

**MAY, 1972/MEN!** With How to Score with Chicks, The Men's Pages, Germaine Spillaine, Stacked Like Me, Norman the Barbarian, and The Zircon As Big As the Talt.

**JULY, 1972/SURPRISE!** With Third World Comics, the Refugee Pages, the Little Black Book of Chairman Mao, How to Be a He-Man, Sermonette, and Col. Jingo's Book of Big Ships.

**AUGUST, 1972/THE MIRACLE OF DEMOCRACY:** With True Politics magazine, The Coronation of King Dick, Gahan Wilson's Miracle of Seniority, and Tales of the South comics.

**SEPTEMBER, 1972/BOREDOM:** With The Wide World of Meat, Our White Heritage, Bland Hotel, the *I Chink*, *National Geographic* parody, and the President's Brother comic.

**OCTOBER, 1972/REMEMBER THOSE FABULOUS SIXTIES?** With Bob Dylan and Joan Baez in Zimmerman comics, Tom Wolfe in Watts, and a long-suppressed Rolling Stones album.

**NOVEMBER, 1972/DECADENCE:** With Sgt. Shriver's Bleeding Hearts Club Band, Defeat Day, the Meat Chess Set, the Fetish Supplement, and Adlai Stevenson in Remnants-of-Dignity Comics.

**DECEMBER, 1972/EASTER:** With Son-o'-God comics #2, Chris Miller's Gift of the Magi, Great Moments in Chess, Diplomatic Etiquette, and the Special Irish Supplement.

**JANUARY, 1973/DEATH:** With The Adventures of Deadman, Playdead magazine, Children's Suicide Letters to Santa, the Last-Aid Kit, plus Bobbie Fisher Shows You How to Beat Death.

**MARCH, 1973/SWEETNESS AND LIGHT:** With the National Inspirer, the Young Adorables, My Own Stamp Album, Pharmacopoeia, and Nice Things About Nixon.

**APRIL, 1973/PREJUDICE:** With Anti-Dutch Hate Literature, All in de Family, The Shame of the North, Profiles in Chopped Liver, Surprise Poster #4, and Ivory magazine.

**MAY, 1973/FAUD:** With the Miracle Monopoly Cheating Kit, Borrow This Book, The Privileged Individual Income Tax Return, and Gahan Wilson's Curse of the Mandarin.

**JUNE, 1973/VIOLENCE:** With the seven Secret Japanese Techniques of Self Defense, Kit 'n Kaboodle Comics, Gun Lust Magazine, and Rodrigues' Hemophunnies.

**JULY, 1973/SCIENCE AND TECHNOLOGY:** With Popular Workbench, Techno-Tactics, Non-Polluting Power Sources, National Science Fair Projects, and the Jersey City Exposition of Progress, Industry & Freedom.

**AUGUST, 1973/STRANGE BELIEFS:** With Psychology Today parody, Son-o'-God Comics #3, Gahan Wilson's Strange Beliefs of Children, and Rubington's Fuzz Against Bunk.

**SEPTEMBER, 1973/POSTWAR:** With *Life* parody, Nazi Regalia for Gracious Living, Whitelove comics, Vichy Supplement, *Guerre Magazine*, and Military Trading Cards.

**OCTOBER, 1973/BANANA ISSUE. WHAT?:** With Saga of the Frozen North, G. Gordon Liddy-Agent of C.R.E.E.P., Amtrak Model Train Catalog, Tales of Nozzlin High School, The Don Juan School of Sorcery, and B. Kliban's Turk.

**NOVEMBER, 1973/SPORTS:** With *Sports Illustrated* parody, Character Building Comics, Doc Freney's Scrapbook of Sports Oddities, Specialty Sports Magazines, 1976 Olympic Preview, Al "Tantrum" O'Neill's Temper Tips, and Bat Day.

**DECEMBER, 1973/SELF-INDULGENCE:** With the *National Lampoon* Building, Our Sunday Comics, *Me Magazine*, An Anglo-Saxon Christmas, Practical Jokes for the Very Rich, How Ed Subitzky Spent His Summer, and *Poonbeat*.

**MARCH, 1974/STUPID:** With the Stupid Aptitude Test, Kancer Kare Kosmetics, The Stupid Group, and *Stupid News & World Report*.

**APRIL, 1974/TRAVEL:** With Gahan Wilson's Paranoid Abroad, Airline Magazine, Amish in Space, RMS 'Tyranic' Brochure, 148 Countries You Can't Visit, and Welcome to *Cheeseburg*.

**MAY, 1974/50th ANNIVERSARY:** With Son-o'-God Meets Zimmerman, New Bulgemobiles, Da Vinci's Notebook Vol. II, Another True Western Romance, Rodrigues' Handicapped Sports, and National Anthems Encores.

**JUNE, 1974/FOOD:** With The Cooking of Provincial New Jersey, *Weighty Waddlers Magazine*, The Joy of Wife-Fasting, *Digester's Reader*, and A Brief Guide to America's Top New Eating Spots.

**JULY, 1974/DESSERT:** With *Famine Circle Magazine*, Gahan Wilson's Baby Food, Corporate Farmers' Almanac, Rodrigues' Gastronomique Comique, and *Guns and Sandwiches Magazine*.

**AUGUST, 1974/ISOLATIONISM AND TOOTH CARE:** With Agnew's A Very Sizeable Advance, *Seed Magazine*, Executive Deleted, Soul Drinks, Surprise Poster #7, and True Menu.

**SEPTEMBER, 1974/OLD AGE:** With Unexciting Stories, Rodrigues' Senior Sex, *Old Ladies' Home Journal*, and *Batfart Comics*.

**OCTOBER, 1974/PUBESCENCE:** With VD Comics, Nancy Drew Meets Patty Hearst, Masturbation Funnies, and Tampon Period Piece.

**NOVEMBER, 1974/CIVICS:** With The Rockefeller Art Collection, Prison Farm, Constitutional Comics, and Watergate Down.

**JANUARY, 1975/NO ISSUE:** With *Negligent Mother Magazine*, Bruce McCall's Zepplin, First High Comics, Watergate Trivia Test, and Night of the Icelless Capades.

**FEBRUARY, 1975/LOVE AND ROMANCE:** With *American Bride Magazine*, Going Down and Getting Off with Brando, Historia de Amor, An Evening at Dingleberch, and The St. Valentine's Day Massacre.

**MARCH, 1975/GOOD-BYE TO ALL THAT:** With Barbar and His Enemies, Gone With the Wind '75, Englandland, The '75 Nobels, The Hotel Throckmorton, and *The New Yorker* Parody.

**APRIL, 1975/CAR SICKNESS:** With *Warm Rod Magazine*, Henry Ford's Diary, Beep, the Bad Little Bus, The 1906 Bulge Buggies, The Tunnel Policemen's Bail, and Gahan Wilson's Shoes.

**MAY, 1975/MEDICINE:** With *National Sore*, Terminal Flatulence, Blue Cross in Peace and War, Rodrigues' Comedics, and Our Wonderful Bodies.

**JUNE, 1975/RAINY DAY ISSUE:** With *Boy O Boy Magazine*, Edward Gorey's The Worst Monster, Parlourbook, Orgy, and Cloo.

**JULY, 1975/3-D ENTERTAINMENT:** With *Fagflag Mag*, The Vespers of 1610, Hollywood, Hooray, Mel Brooks Is God, Airport '69, and Glitter Bums.

**AUGUST, 1975/JUSTICE:** With the Rockefeller Attica Report, Code of Ham-murabi, *Citizen's Arrest Magazine*, Inherit Their Wind, and World Night Court.

**SEPTEMBER, 1975/BACK TO COLLEGE:** With the Vassar Yearbook, Football Preview, Scholastic Scams, Academic Ploys, and the *Esquire* Parody.

**OCTOBER, 1975/COLLECTOR'S ISSUE:** With Pornography for the Dumb, Underwear for the Deaf, *Myth and Legend Mirror*, the Mayo Clinic, and THE INFAMOUS CUBAN HOMO FARM.

**NOVEMBER, 1975/WORK:** With Ferdinand the Bulldozer, The Kitchens of Sara Lee, Trail of Tiers, *Shirking*, and Hire the Handicapped.

**DECEMBER, 1975/MONEY:** With The Great Price War, Entrepreneurs, and a *Fortune* parody.

**JANUARY, 1976/SECRET ISSUE:** With Jackie's Date with Destiny, *The New York Review of Books* parody, IRA Comics, Couched in Secrecy, and The Conspiring Photographer.

**FEBRUARY, 1976/ARTISTS AND MODELS:** With *Simply... Picasso*, Art Dreco, Clowning Around with Tils, the *ARTnews* parody, and the Lincoln, Nebraska Center for the Performing Arts.

## THE NATIONAL LAMPOON

Dept. NL 476, 635 Madison Avenue, New York, N.Y. 10022

Send me the following:

No. of copies	Issue	No. of copies	Issue	No. of copies	Issue
_____	Oct., 1971	_____	June, 1973	_____	Nov., 1974
_____	Dec., 1971	_____	July, 1973	_____	Jan., 1975
_____	Mar., 1972	_____	Aug., 1973	_____	Feb., 1975
_____	Apr., 1972	_____	Sept., 1973	_____	Mar., 1975
_____	May, 1972	_____	Oct., 1973	_____	Apr., 1975
_____	July, 1972	_____	Nov., 1973	_____	May, 1975
_____	Aug., 1972	_____	Dec., 1973	_____	June, 1975
_____	Sept., 1972	_____	Mar., 1974	_____	July, 1975
_____	Oct., 1972	_____	Apr., 1974	_____	Aug., 1975
_____	Nov., 1972	_____	May, 1974	_____	Sept., 1975
_____	Dec., 1972	_____	June, 1974	_____	Oct., 1975
_____	Jan., 1973	_____	July, 1974	_____	Nov., 1975
_____	Mar., 1973	_____	Aug., 1974	_____	Dec., 1975
_____	Apr., 1973	_____	Sept., 1974	_____	Jan., 1976
_____	May, 1973	_____	Oct., 1974	_____	Feb., 1976

I enclose a total of \$\_\_\_\_\_ at \$1 for each copy requested. This amount covers purchase plus shipping and handling.

My name \_\_\_\_\_

Address \_\_\_\_\_

City \_\_\_\_\_ State \_\_\_\_\_ Zip \_\_\_\_\_

# 2 FREE SCREWS

SCREW, the weekly sex review, wants to meet you. Order any subscription and we will immediately send you two SCREWS absolutely free.

SCREW: the most outrageous and controversial newspaper published. And, when it comes to sex, SCREW is always first with the most exciting photos, interviews, news, plus reviews of current films, books, and products...all of it delivered with doses of Swiftian satire and side-splitting humor guaranteed to keep all your glands glad.

There's nothing quite like a SCREW. Check it out. Order any subscription—even the super-cheap 10 issues for \$9.95—and get a bonus of two SCREWS free.

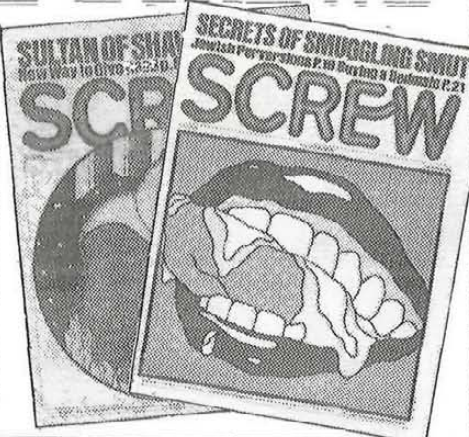

....Special Introductory Offer: 10 issues for \$9.95 NL-2  
 26 issues ....\$19.95 (3rd Class mail) or ....\$34.95 (1st Class mail)  
 52 issues ....\$37.00 (3rd Class mail) or ....\$59.95 (1st Class mail)

Name .....  
 Address ..... Apt. No. ....  
 City ..... State & Zip .....

I certify by my signature that I am not a postal or government agent engaged in entrapment and that I am of legal age .....

Make check or money order payable to: Milky Way Productions, Inc. Mail to: Subscription Dept., P.O. Box 432, Old Chelsea Station, New York, N.Y. 10011.

## Valley High

continued

Pit, where the Cardinal Pitsky team always hangs out until curfew during the football season. I headed right toward the hallway and team co-captain Mike Hannihan. Bobbi'd said for us to all say something about how we'd like to have some fun but we heard that Catholic boys can't eat meat on Friday. But I thought that sounded awful, and besides, nowadays they can. So I just waited until he said "Hi" and right away worked water beds into the conversation so he'd think I was a hot date.

It wasn't long before Mike and I had taken a ride in his car to this place in Mt. Adams where there is a special view of the river, if you know what I mean, and he was getting very romantic with my bosom. I was wearing this tight pair of jeans and pretty soon he was getting very romantic with the outsides of those also which I wouldn't let him undo exactly, but I held my tummy in and leaned over some so he could, well, you know. I mean after a while, I did. And after a while more, he kind of tugged on my hand to get it to be romantic with him too which was where I had to be careful because Jimmy Duncan and I used to get romantic like that and one time we got so romantic that he ruined my best Huckapoo blouse (I had it dry-cleaned and everything), and the whole point of Bobbi's plan was that Catholic boys can't go home and relieve themselves. Romantically, I mean. Besides although I practice birth control that's all it is, just practice.

Anyway, about 3:00 A.M. I told him something like that I was getting my time of the month any minute but would he promise to call me? And I gave him the number of the pre-recorded weather forecast and we went back to the Burger Pit where the other girls had been with the other Cardinal Pitsky team members though there had not been enough of us to cover the second and third squad members which we had left in the care of Bobbi Duckworth, and I'm afraid she may have been gang-petted.

### V. That Saturday's Game

Well, Saturday we managed to win the game against the Cardinal Pitsky Penguins even without the "Three Donkeys" and even with a sickly-looking backfield. Coach Slumbach right away noticed that the Penguins were walking like the bird that they're

## CORDLESS TELEPHONE

Operates as any extension phone except it's cordless. You can take it anywhere, indoors or out. Pool, yard, basement, attic, even in your bathtub — anywhere within 300 feet of your home. Receive calls or dial out.

### EASY TO INSTALL

Your Portaphone operates in conjunction with all regularly installed telephone equipment you already have. Installation takes 30 seconds and you do it yourself easily and without tools.

### 100% SOLID-STATE RELIABILITY

Portaphone is manufactured with 100% space-age solid-state circuitry. No moving parts to wear out. No tubes to replace. For years of trouble-free performance. Guaranteed for 1 year.

### REAL COST IS \$2.00 PER MONTH AND IT PAYS FOR ITSELF

If you divide the purchase price by the estimated 15-year useful life of the Portaphone, the cost is only \$24.00 per year, or only \$2.00 per month. It pays for itself by replacing an existing extension phone and eliminating another extension.



**SATISFACTION GUARANTEED OR MONEY BACK**  
**EAST AND MIDWEST ORDERS SHIPPED BY AIR**

Send check or money order to: J-1  
 JLR Corp.  
 16200 Ventura Blvd. (213) 986-4271  
 Encino, CA 91436

Please send me \_\_\_\_\_ Cordless Portaphones at \$395 each, plus postage, handling and insurance \$5.50. California residents add 6% sales tax.

Name \_\_\_\_\_  
 Address \_\_\_\_\_  
 City \_\_\_\_\_ State \_\_\_\_\_ Zip \_\_\_\_\_

named after. And they weren't running so well, either. Especially Mike Hannihan, I'm proud to say. The Penguins' best pass thrower, Xavier Murphy, kept crying while he was on the bench and kneeling down to pray all through the game. He threw one pass into the stands and knocked a Coke vendor all over some nuns and he threw one right into the ground and then he went to cock his arm for another pass and hit himself in the face with the ball. Valvoleen, who was with him at the Burger Pit, said he's studying for the priesthood, or was until last night. They did make one good play where their fullback was in the clear for about a fifty-yard run to make a touchdown, but he only got halfway there when he had to stop and catch his breath and Grover and "Flaky" and Jimmy Duncan tackled him in the head. In fact, the only time they came close to scoring was on a field goal while I was between cheers and chatting with some of the girls in the stadium first row and their kicker couldn't get his leg above knee-high and fell down clutching his personal parts. When that happened, Patsy Entwhistle just blushed and blushed. So we won by several touchdowns

to nothing although we were still awfully short of players and at one point I helped Coach Slumbach and the Badgerettes dress Shrimp Hargis in a uniform and send him out on the field. We were all hoping for something like in the movies where Shrimp finally had his chance to play and would show everybody at last, but he just got hurt.

Mike Hannihan saw me as he was sort of waddling back to the huddle near the end of the game and I just smiled like nothing had happened.

#### VI. Another Week During Which There Were a Lot of Complicated Problems

As the week before the game with Lawnmoor Hills began, we thought maybe things would get better. So many of the first string guys were out of it that some of the Second String Liberation Front had come back, since now they were the first string anyway and were saying that maybe that second string liberation stuff was pretty silly after all. Also, we weren't too worried about this game with Lawnmoor Hills because Lawnmoor Hills is all Jewish and some of the mothers won't even let their sons play golf for fear they might be hit in the head and

not get into medical school. Every time they play a game they all lose their contact lenses, and last year their quarterback got his braces tangled in the chin strap of his helmet and mumbled the signals so bad that they punted when they didn't have the ball and we scored from our own twelve yard line.

But what we weren't counting on was Dorothy Munson with the buck-teeth and her scaggy Women's Rights Club. They decided to protest the fact that the football team isn't 51 percent girls and went into the football locker room and held a shower-in, although they wore their bathing suits and the boys weren't there at the time anyway.

Coach Slumbach went to the principal, but Mr. Levinsky told Coach Slumbach to let girls come out for the team. He said Coach Slumbach should "respond to the demands of the women's rights movement." So Coach Slumbach responded by cutting everybody who couldn't run 100 yards in fifteen seconds with all their equipment on. Unfortunately, this turned out to be everybody entirely except Randy Lockerwood and Johnny Hartman, who jog all the time and had started eating again.

*continued*

## Plain Shirts Are For Plain People

Not for you, Roach custom-makes your own from over 300 imaginative designs. In full color.

Get one for a friend and save a dollar.

5004      5032      5074      5104      5125

5094      5098      605      599      566

5119

682      563      529

4038      4037      4032

Please cut out and mail coupon

Dear Roach, I've enclosed a check or money order. (Ohio residents add 4% tax. Canadians 10%). Send my fade-free machine washable selections in 4-6 weeks. I would like your 36 page catalog of designs for \$1.00. Thanks for saving me a buck on 2 or more shirts. Design on shirt back \$1.00 additional. Iron-on transfers \$1.50 each or 3 for \$3.00.

Name \_\_\_\_\_  
 Address \_\_\_\_\_  
 City \_\_\_\_\_ State \_\_\_\_\_ Zip Code \_\_\_\_\_

White T-Shirt \$3.95    Navy  Powder Blue  Royal Blue  Red   
 Color T-Shirt \$4.95    Grey  Black  Maroon  Yellow  Gold

Style	Size	Color	Quantity	Price

Postage & Handling \$ .35 per shirt    Sales Tax Total \$ \_\_\_\_\_

Roach PO 182 Worthington, Ohio 43085

NLA-76



## Valley High

continued

It looked like time for the Honors Pep Gym to swing into action again.

### VII. The Honors Pep Gym Swings Into More Action

It's really not that hard to run a hundred yards that fast, even wearing all that football stuff. I tried it with my arms full of books in a pair of wedgies just to see. Valvoleen Cleveland told her brother...well, she told him a lot of things. Anyway, he agreed to try harder rather than have to talk to Mrs. Cleveland and the next day ran 100 yards in 10.5 with no trouble at all. Bobbi Duckworth put some incentive back into "Flaky" Albertson and Jimmy Duncan by having a discussion with them about the possible future lack of certain stuff that her friends at the University of Cincinnati usually have. "Flaky" and Jimmy were able to do it in fourteen seconds. Shrimp Hargis managed to do it on the fifth try after he'd taken off the heavy football shoes that didn't fit him and we painted his feet black so Coach Slumbach wouldn't notice. Dilly Hutchinson had promised to take him to see Patti Smith, whom he looks a

lot like, at Covington Community College if he could do it. Also, I convinced Jack Shinn and Bob Chumley that if the Venusians were able to fly all the way to earth they would certainly be able to find Jack and Bob over on the football field only forty feet away from the parking lot.

### VIII. The Next Saturday's Game

That gave us eight players. Thank gosh it was only Lawnmoor Hills that we had to play against. We found one uniform that fit Bobbi Duckworth pretty well. Bobbi is statuesque in a large statue sort of way. And one that fit Dilly. And I dressed up in another one. The Lawnmoor Hills team lost their contact lenses as usual and we made one touchdown while they were looking for them because they forgot to call time out. One of their guys in the backfield, Davey Sheenbaum, was actually playing pretty good that day, but Bobbi got at him with her nails in a pileup and when he saw the marks he thought he was having an allergy attack and was taken out of the game so he could go to the dermatologist. It was all pretty simple. The Lawnmoor players were easy to block because of the way they cover their faces with

their hands when you rush at them. Also, Dilly and I had played catch football with my little brother lots of times and we both toss a football fine for girls, though I throw it farthest when I use both arms underhand. Anyway, we won by two to one, that is, twelve or thirteen to six or something and quick ran in to get changed, especially out of those elastic bandages we used around our chests, before Coach Slumbach noticed. But he was so depressed that I don't even think he noticed that our team won.

### IX. Still Another Week with Even More Complicated Problems

Only a week to go before the game with undefeated Marcus Garvey High. Marcus Garvey is all Negro and they're really gigantic and some of them have flunked eight or twelve times. Even Valvoleen and Grover won't go into the Garvey neighborhood. I heard they have knife fights to determine who gets to play what position. When they played Lawnmoor Hills last year, one of them threw a pass so hard that it broke three of this Jewish kid's ribs when he tried to intercept it. They are undefeated since 1970. Fortunately, they are almost always disqualified for the championship. Unfortunately, this year they aren't. One year they were disqualified because there was a riot after one of their games where three people got killed. Though that was a game with another Negro school. Another year they got disqualified because their defensive end was carrying a gun during the game. The courts were going to bus some white kids into Marcus Garvey to help the racial balance, but when they heard about it, all 250 of the kids who were going to be bussed got together and broke into a Dairy Queen so they'd be sent to reform school. The teachers at Marcus Garvey all carry these electric cattle prod things because so many of the students are immune to Mace. They had to put that chain link fence stuff over all the school windows to keep the kids inside, even on the third floor. Three of their cheerleaders are unwed mothers. Marcus Garvey is really a tough school.

We had managed to get some of the team, about fifteen of them, back together pretty well. The women's rights girls were still mad about being cut, but they didn't do anything about it. I think that once they'd found out what football equipment smells like, they lost a lot of interest.

get off e-z

e-z wider™  
double width rolling paper

e-z wider... easily the best

E-Z Wider, the original doublewidth rolling paper, makes rolling easy. The double width eliminates the hassle of sticking two single width papers together. And E-Z Wider is the standard of quality: finest glue, slow even burn—and the watermark signifies a perfect thinness of paper.

© 1976 Robert Barron Associates, Inc.

So it went all week, and things were looking as good as could be expected, which wasn't too, until Friday night before the game. That was when Coach Slumbach got an anonymous phone call that the entire team was down at the Electric Toilet juice bar taking drugs and breaking curfew.

After all we'd done for those guys, and on this, the night before the deciding Hesseran Oldsmobile Trophy game, to have them in the Electric Toilet which is actually decorated like a bathroom. I'm serious. You sit on these chairs made out of toilets which are all set back in stalls, the napkins come out of toilet paper dispensers, there are light fixtures in urinals on the walls, and the bar is supposed to look like a row of sinks, and there's horrible dirty graffiti all over everything. They only serve soft drinks there but it's where all the really druggy people hang out and sell each other diet pills and Quaaludes and I don't want to know what else.

#### X. The Saturday's Game after That

There was only one thing to do in the face of the game with Marcus Garvey. It was a little less legal than some of the other stuff we had done, but Coach Slumbach was nowhere to be found and we figured there wouldn't be a lot of complaints from anybody at Valley High. Frankly, not many people come to high school football games anymore. I mean, not many white people. Lots of Marcus Garvey parents would be there because they don't have group therapy or play squash at the club on Saturdays.

I don't think any of the Garvey players had any idea of what was going on at first because we sent Cindy Munson, this baton twirler who's really flat and tall and skinny, out to be captain and we won the toss and they kicked off to us and we made a safe catch watchamajigger and everything was as usual until everybody lined up for the first play. This time we hadn't fooled around with any elastic bandages or anything like that. In fact, we'd taken some tucks in the jerseys so they fit a lot better. All the Marcus Garvey players got crouched down for defense while we huddled and then we ran up and got crouched down face to face with all these really huge Negro guys and their eyeballs just got all bugged out and their mouths dropped open and they all stood up and started scratching themselves on their helmets and turn-

ing around and looking at each other and staring at us and acting really confused. And while they were doing that, Valvoelen whispered "Hike" and put the ball under her arm and slowly walked down the field and touched down. There was a lot of horrible noise and stuff in the Marcus Garvey stands after that happened, but their team was still looking very mixed-up as were the referees, who are usually not too attentive, especially at games with Marcus Garvey. We rapidly got ourselves ready to kick off before they could get organized, but that didn't work too well because of how large Patsy Entwistle's football pants were on her and they fell down when she ran up to place kick and this one gigantic Negro rushed right in and grabbed her instead of the ball, which clearly caused some kind of penalty business where we all had to line up very far back toward their end of the field. They had the football this time but when they started to play, some of them got a look at Dilly Hutchinson and they all ran toward her, the quarterback with the ball included, even though where Dilly was was not in the direction of the goal at all. (I think colored guys like their girls sort

*continued*



**FREE!** Battery Operated Vibrator With Every Order! **\$2 Value!**  
**TRY US FIRST! LOWEST PRICES IN THE U.S.A.!**

**DISCOUNT  
 CONDOMS  
 BY MAIL!**

**NEW EXCLUSIVE LINE  
 OF SPECIAL EUROPEAN CONDOMS!  
 FIRST TIME IN U.S.A.!**

**WHY PAY MORE?**

**We Stock All Top Brands At Prices Way Below Retail!**

Huge discounts by the dozen and by the gross. Our special sampler assortments give you much more for your money. We have them all: skins and latex...lubricated and dry...plain or nipple ends...in colors, textures, contoured...you name it, we've got it! Factory fresh stock of all name brands...Trojans, Naturalamb, XXXX Fourx Skins, Stimula, Tahiti, NuForm plus all others at DISCOUNT PRICES! We have our own computer for immediate order processing and shipment. All orders shipped in plain wrapper. Satisfaction Guaranteed or Money Refunded. Our Giant Discount Catalog FREE With Every Order!

**UNIQUE DISTRIBUTORS INC.** Dept. NL-150

Box 1441, Grand Central Station, New York, N.Y. 10017

Gentlemen: Please rush me the following in plain sealed wrapper

- 15 Ass. Condoms - 5 Different Brands - Sampler \$3
- 25 Ass. Condoms - 10 Diff. Brands - Deluxe Sampler \$5
- 50 Ass. Condoms - 15 Diff. Brands - Super Deluxe Sampler \$10
- 100 Ass. Condoms - 20 Diff. Brands - Ho-Man Sampler \$20
- Condom Discount Catalog - \$1.00 (FREE With Order)

I have enclosed \$ \_\_\_\_\_ Cash  Check  Money Order

I have enclosed a \$2 Deposit. Please Ship C.O.D.

Name \_\_\_\_\_

Address \_\_\_\_\_

City \_\_\_\_\_ State \_\_\_\_\_ Zip \_\_\_\_\_

(New York State residents please add appropriate sales tax)

**SAVE MONEY! Enclose full payment SAVE Postage & C.O.D. charges!**

**remarkable aid  
 to greater  
 sexual  
 compatibility**

Premature climax frequently frustrates the fulfillment of a truly satisfying relationship between man and woman.

Detane is a desensitizing lubricant that provides dependable climax control for men... leading to increased sexual contentment for both partners.

Detane is an unscented invisible gel. Available without prescription at leading pharmacies.

**DETANE® THE CLIMAX CONTROL FOR MEN**

© 1975 Commerce Drug Co., Inc., Farmingdale, N.Y. 11735

# Five foolproof ways to Pick up and seduce girls!

## How to pick up girls!

Pick up girls in bars, buses, trains, even on the street! It's easier than you ever dreamed possible. You will learn:

- How to make shyness work for you
- Why a man doesn't have to be good-looking
- Why girls get horny
- 50 great opening lines
- World's greatest pick-up technique
- How to get women to pick you up.

Book contains in-depth interviews with 25 beautiful girls. They tell you exactly what it takes to pick them up.

Only \$8.95 plus \$1.00 postage & handling.  
Send to: **Symphony Press, Inc., Dept. MB, Box 515, Tenafly, N.J. 07670.** (see coupon below).

### HOW TO PICK UP GIRLS!



## How to make love to a single girl!

### HOW TO MAKE LOVE TO A SINGLE GIRL

will turn you into such an exciting lover, women will sense your powers the instant you walk into a room. Over 160 luscious photos show you how to turn on a single woman. You will learn:

- Where to touch a girl first
  - How to make a woman "let herself go"
  - The aphrodisiac touch
  - How to excite a girl with just words
  - How to give a woman multiple orgasms
  - How to arouse her with a single kiss.
- Who says you have to be good-looking to attract lots of single girls?! This book can help you become the kind of lover women can't wait to go to bed with!

Only \$12.95 plus \$1.50 postage & handling.  
Send to: **Symphony Press, Inc., Dept. MB, Box 515, Tenafly, N.J. 07670.** (see coupon below).

### How To Make Love To A Single Girl



## Valley High

*continued*

of big.) About the time this was happening, the Garvey cheerleaders realized what was going on and ran out onto the field meaning to probably kill us with the razor blades I understand that they keep concealed in their hair. But the first one of us that any of them got to was Valvoelen Cleveland, who stepped on the girl's gym shoe extra hard with football cleats. So the Garvey cheerleaders all started to attack their boyfriends on the team instead and a moment later all kinds of Negroes started pouring out of the visitors' bleachers and a lot of screaming and yelling and pistol shots began to start so we quickly got out of there, figuring that Marcus Garvey had forfeited the game more than we had. Which we were right about and the Hesseran Oldsmobile Trophy was awarded to us in a quiet little ceremony behind the snack truck while the police straightened things out in the stadium with shotguns.

### XI. The Ice Ball

We'd done it! We'd actually done it! In spite of everything, we'd managed to win the North Suburban League Championship. Bobbi Duckworth slipped away to go downtown right about then. At the time I didn't know where she went and just figured she was overcome by emotion about the trophy and all.

I don't know how long it was before we heard this truck pull up at the loading dock beside the cafeteria. It was one of Bobbi Duckworth's dad's trucks and then Bobbi got out still in most of her football uniform and opened up the back and out climbed all these guys.

Some were little and real good-looking and dressed very neatly with really short hair and some had beards though they kept them all trimmed and one ring in their ears like pirates and some were in jumpsuits sort of like astronauts but skinnier and more on the cute side and some looked very tough in motorcycle jackets and blue jeans and engineers' boots with lots of keys hanging from their belts but very clean and not mean looking at all. They were all sort of giggling and talking excitedly among themselves as they came into the lunchroom through the kitchen, and you could smell that they were wearing really nice colognes. "They know how to dance close," yelled Bobbi, "and they'll treat us like queens."

## THE PICK UP SYSTEM NO GIRL CAN RESIST!!

### PICKING UP GIRLS MADE EASY!



This 40 minute album (or cassette) has eight actual recorded pick up scenes to learn from. You'll hear exactly how to pick up a busty college girl in a library, a tall pretty blond on the street, a dark-haired sexy swinger in a single's bar. You'll also learn how to get a girl out of a bar and into your bedroom in less than an hour... and how to tell when a girl is horny just by the sound of her voice.

You'll actually hear the voices of the people involved: the men, as they begin to work their magic — the women as they fall willing victim to their charm. *Everything* is spelled out for you, from attention-getting opening lines... to fool-proof closing lines that get you her telephone number, date, and sometimes even her body right then and there.

So send for PICKING UP GIRLS MADE EASY today. It's guaranteed to turn you into an expert picker-upper and seducer.

Indicate whether you're ordering album or cassette and send \$8.95 plus \$1.00 postage and handling to: **Symphony Press, Inc., Dept. MB, P.O. Box 515, Tenafly, N.J. 07670.** (see coupon below).

## 900 Action Spots where you're guaranteed to score!!

Learn the names and addresses of 910 great places to pick up girls. Places where the girls are so luscious and horny, you'll take one home with you nine nights out of ten! You'll discover: ★ a discotheque where girls are so liberated you can take one home and return for another the very same evening ★ a bar where girls ask you to dance if you don't ask them ★ a nude beach where hundreds of tanned naked girls sit around just waiting for you to approach them.

This book takes you to the hottest action spots in America's twenty-six major cities. You'll also learn about fool-proof pick up spots within five miles of your own home! You'll discover the secret, after-hours hang-out spots of sexy nurses, wild stewardesses, beautiful models and horny divorcees. So send for AMERICA'S BEST PICK UP SPOTS today. It'll take you to dozens of horny women who are sitting there waiting for you at this very moment.

Send only \$8.95 plus \$1.00 postage and handling to: **Symphony Press, Inc., Dept. MB, P.O. Box 515, Tenafly, N.J. 07670.** (see coupon below).

### AMERICA'S BEST PICK UP SPOTS!



## 100 GREAT OPENING LINES!

Here are 100 clever, witty, fool-proof opening lines. Each is designed to instantly get a girl's attention and interest. And each has been tested and proved at least 95% effective!!

These lines work like magic on buses, subways, trains and planes... in discotheques, restaurants and bars... while out bicycling, hiking, skiing, or playing tennis... in record stores, book stores, boutiques... and in offices, classrooms and elevators — in fact just about anywhere! This is a handy, pocket-sized edition you can carry with you for easy, instant reference. If you've got the right line, you can get the right girl! There's no doubt about it. So send for 100 GREAT OPENING LINES today.

Costs only \$4.95 plus 50¢ postage and handling. Send to: **Symphony Press, Inc., Dept. MB, P.O. Box 515, Tenafly, N.J. 07670.** (see coupon at right).

**Symphony Press, Inc., Dept. MB, P.O. Box 515, Tenafly, N.J. 07670**

- Send me HOW TO PICK UP GIRLS (only \$8.95 plus \$1.00 postage & handling)
  - Send me HOW TO MAKE LOVE TO A SINGLE GIRL (only \$12.95 plus \$1.50 postage & handling)
  - Send me PICKING UP GIRLS MADE EASY — the record, — the cassette (only \$8.95 plus \$1.00 postage & handling)
  - Send me AMERICA'S BEST PICK UP SPOTS (only \$8.95 plus \$1.00 postage & handling)
  - Send me 100 GREAT OPENING LINES (only \$4.95 plus 50¢ postage & handling)
- Order two or more items and deduct \$2.00 from your total payment.

Name \_\_\_\_\_  
Street \_\_\_\_\_  
City \_\_\_\_\_ State \_\_\_\_\_ Zip \_\_\_\_\_

All orders arrive in non-identifiable wrapper.  
© Symphony Press, Inc., 1976

# T-SHIRTS! T-SHIRTS!

catalog 25¢ including: POSTERS & PHOTOS  
 NEW SPRING EDITION  
 many NEVER BEFORE SEEN DESIGNS  
 including: QUEEN-LED ZEPPELIN · KISS  
 BLUE OYSTER CULT · BLACK SABBATH  
 THE WHO · JACKSON BROWNE · DYLAN  
 RENAISSANCE · BAD COMPANY · YES  
 LINDA RONSTADT · MOTT THE HOOPLE  
 TODD RUNDGREN · STONE'S TOUR '75  
 ALLMAN BROS · DOOBIE BROS · BTO  
 BEACH BOYS · DEEP PURPLE · DENVER  
 HENDRIX · CAT STEVENS · STARSHIP  
 WHY PAY MORE? \$3.25 per shirt, 4 shirts for  
 \$14.00: N.Y.S. residents add 8% sales tax  
 Money Orders or Cash get same day  
 service: Allow two weeks for checks  
 Assorted Colors: Men's sizes: S-M-L  
 Wholesale & Retail requests welcome  
 THE T-SHIRT BARN DEPT NB4  
 SLATE HILL, NEW YORK 10973

**KILO CLIP**  
 OR SIMPLY SEND FOR  
**FREE COLOR**  
**CATALOGUE**

A key roach clip. Always there when you need it. \$2.00 (postage & handling inc.)

**RARE TREASURES LTD.**  
 30-50 Northern Blvd., Dept. N10  
 Long Island City, NY 11101

**FOR THE LADY'S MAN**

Here is the indispensable guide to make sure that your style is polished and perfected. This book, written by a California attorney, reveals all the techniques you need to meet, charm and make it with beautiful women. It is the best investment you will ever make to start leading a full and exciting love life.

**SEDUCTION WITH STYLE** — shows you how to attract women no matter how wealthy or handsome you are — gives you dozens of the author's secrets to instantly increase your sex appeal — will make you become immediately intimate, confident and relaxed with even the coldest of women.

**YOU CAN'T LOSE.** If you're not completely satisfied just return our book and your complete refund will be mailed in three days. Mail \$8.70 today (check or m.o.) to D and G Press, Dept. NL 4, P.O. Box 9518, Marina del Rey, CA. 90291. Cal. res. add \$3.48 sales tax.

**NATIONALLY ADVERTISED BRANDS!**  
**CONDOMS BY MAIL!**  
 SENT FIRST CLASS IN UNMARKED WRAPPER.

End using sensation deadening condoms. Get gossamer thin supremely sensitive condoms designed for sexual pleasure. W.P.C. offers reliable nationally advertised brands of condoms including Trojan products. Fourx. Featherlite! Order from your own home without embarrassment. Shipped within 24 hours. □ 12 condoms (4 different brands) only \$3. □ Deluxe package (6 different kinds) 24 condoms \$6. □ Super Deluxe package 100 condoms (8 different kinds) \$20. For air-mail add \$1. postage.

World Population Control, Dept 138  
 P.O. Box 90 Newark, N.J. 07102

**Sold on Money Back Guarantee**

**NOTIONS AND LOTIONS**  
**LATEX AND LEATHER**

THE PINK PUSSYCAT BOUTIQUE  
 SEND \$3.00 FOR CATALOGUE  
 P.O. 421 L · REGO PARK, N.Y. 11374

**FREE RECORD COLLECTION**  
 Reviewers Wanted: (No Experience Required)  
 We ship you NEW records to review. All you pay is postage & handling. You pay nothing for any records. Applicants accepted on "First Come Basis." For application write: NATIONAL RESEARCH, Dept. N, 3725 N. 126th St., Brookfield, Wisconsin 53005.

**WARNING!**  
 Horseshit Magazine

Most people go into a state of shock when they first open a copy of Horseshit. Then they go about halfway through, reading and looking at the pictures, and they have to put it down and try to get their breath back again. When they've rested up, they go through the rest of the magazine. Then they put it down and they don't know what to think. The next day they read it again and decide they like it. The day after that they decide it's GREAT! They show it to their friends. Then they have to sit there and listen while their friends yell and shout with laughter and point out things they particularly like. Soon, other friends come over, dozens of them. "We want to see THAT magazine," they say. Finally, some bastard steals their Horseshit. Then there's nothing left to do but order a new subscription from us. You might as well get started now. Be ready for a shock.

FOUR ISSUES FOR \$10 2 issues for \$5  
 Gift cartoon book with \$10 orders.  
 ORDER NOW FROM

**EQUINE PRODUCTS • BOX 361-C**  
**HERMOSA BEACH, CALIF. 90264**

NOT SINCE THE BIBLE HAS ANY BOOK REACHED SUCH DEPRAVITY AS HORSESHIT.

Horseshit is always mailed in plain sealed envelopes.

**AUDIO SALES REPS WANTED**

We need people to help sell our high quality audio components at huge discounts. Sell in your area or on campus. Earn big bucks, no capital outlay required, no experience necessary.

For complete information, call or write to:  
**ABCO Dept. CR-915**  
**Grand Avenue New Haven, Conn. 06511**  
**203-777-7887**

**HOLY SHIRT!**

You'll look positively divine in something from our Holy Shirt Collection. Quality, American made T-shirts in either Basic Black or Cardinal Red Holy Shirts. Buy lots. It's the Christian thing to do.

To order, fill out coupon and mail to:  
**Sand Castle Enterprises, P.O. Box 589, Foxboro, Mass. 02035**  
 Please send me Holy Shirts at \$3.95 (include 50¢ for postage and handling, per shirt, Canadian orders \$1.00 per shirt. Please check  Basic Black  Cardinal Red  
 Srs  Med  Lg  X-Lg  
 Enclosed is \$ \_\_\_\_\_  check  money order  
 Name \_\_\_\_\_  
 Address \_\_\_\_\_  
 City \_\_\_\_\_ State \_\_\_\_\_ Zip \_\_\_\_\_

**SENSUOUS**  
**CONDOMS**  
**BY MAIL!**

Now you can order top quality condoms privately by mail . . . and save money! We feature all brands including Trojans, textured Nücken and preshaped Profil.

**Population Planning, Dept. DNL18**  
**403 Jones Ferry Rd., P.O. Box 400**  
**Carrboro, N.C. 27510**

Please rush the following in a plain package:  
 Sampler of 12 assorted condoms \$3  
 Deluxe sampler of 25 assorted condoms \$6  
 Super 100 Sampler of 100 condoms \$20  
 Illustrated catalogue 25¢

Name \_\_\_\_\_  
 Address \_\_\_\_\_  
 City \_\_\_\_\_ State \_\_\_\_\_ Zip \_\_\_\_\_  
**Satisfaction Guaranteed—300,000 Customers**



**SATIVA**  
 The '76 LIBERTY KIT

Comes with:  
 Screens  
 Pipe Cleaners  
 Stand-up Pipe  
 Clip  
 Matches  
 Papers

Reusable Stash Bag  
 Carrying Case

**\$3.00**

The Liberty Kit contains all the "goodies" you need to help celebrate at a celebration price!

**TWO MORE GREAT KITS**

#5-21 comes w/ Ex-tenda-pen clip, stand-up pipe, 2 bowls, screens, papers & its own lighter. \$10.00  
 #5-16 comes w/ Bullet hide-a-clip, stand-up pipe, 2 bowls, screens, and papers. \$6.00

Send cash, check or money order to: Sativa Sales, Dept. L476, P.O. Box 30272, Terminal Annex, L.A., CA 90030. Add \$1 for post. & hdg. Allow 4 weeks for delivery. Calif. residents add 6% tax.

Please send me the following kit(s):  
 #5-50 Liberty Kit;  #5-21;  #5-16  
 Enclosed is \$ \_\_\_\_\_

Name \_\_\_\_\_  
 Address \_\_\_\_\_  
 City \_\_\_\_\_  
 State \_\_\_\_\_ Zip \_\_\_\_\_  
 Check here for our FREE CATALOG.

# IRON-ONS, 79c POSTERS and up

Raylen Arts winter Iron-On and Poster deals are F\*CK'N GREAT! So are our poster designs. All Iron-Ons are about 8" x 11".

**INSTANT POSTER COLLECTION**  
\$20.00 worth of posters now only \$4.98. You get a little of everything: sex, politics, personalities, etc. At least 10 posters in every package. It's the poster deal of the century.

POSTERS:  
C means color

**\$2.00 23" x 29" X58**  
**\$2.00 30" x 40" X15**  
**\$2.00 30" x 40" X1** 79c 30" x 40"  
**\$2.00 30" x 40" X63**  
**\$2.00 23" x 29" X42**  
**\$2.00 30" x 40" X62**  
**\$2.00 30" x 40" X17**  
**\$2.00 30" x 40" X64**  
**\$2.00 22" x 28" X4**  
**\$2.00 30" x 40" X3**  
**\$2.00 30" x 40" X23**  
**\$2.00 C 30" x 40" X76**

ALL THE IRON-ONS ARE COLOR

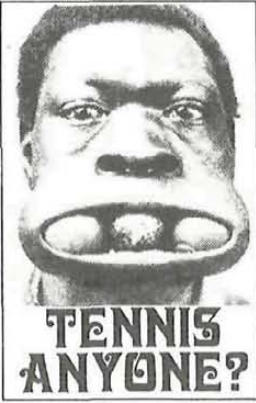

**\$2.00 30" x 40" X23**  
**\$2.00 30" x 40" X62**  
**\$2.00 30" x 40" X17**  
**\$2.00 30" x 40" X64**  
**\$2.00 30" x 40" X63**

NEW!



**\$5.98**  
**AMERICAN EAGLE DESIGN FOR YOU KNOW WHAT!** The best buckles we have ever offered. Truly distinctive. Almost 1/2 of an inch thick. Fits all 1" and 2" belts. Size is 3 3/4" square. Brushed silver NX4. Brushed bronze NX3.

## INDIAN HEAD BUCKLE



**\$4.98 289K**

**\$2.00 30" x 40" X52**  
**\$2.00 30" x 40" X37**  
**\$2.00 30" x 40" X65**  
**\$2.00 30" x 40" X47**  
**\$2.00 30" x 40" X67**

**CRAZY** luck ins are giant full color transfers that actually tuck right into your pants. You iron them on as shown. **TREAT FOR ONLY \$1.98 each.**

**\$1.98 R 73**  
**\$1.98 R 70**  
**\$1.98 R 68**  
**\$1.98 R 77**

## NIXON COLLECTOR'S ITEMS

**X68 Certificate of Proof**  
On parchment we have printed a standard 9" x 12" legal certificate of proof that you did NOT vote for or in Nixon-Agree in 1972. Perfect for framing. Space provided for your name and date. Keep for custody only \$1.98. \$3 for \$4.98. Very official looking. Designed to be notarized.

**\$2.00 C 25" x 35" X69**  
**\$2.00 C 25" x 35" STONED AGAIN**  
**\$2.00 23" x 29" BW \$2.50 X67**

## OUT OF ORDER

**N-75 STRIKE BACK.** Save a friend a dime! Use our own pressure sensitive CRIT OF ORDER stickers on BURN PHONES, etc. A great weapon! Black on Yellow. Pad of 25, just 50 cents. Satisfaction guaranteed! Special Three packs \$1.00.

To OFFSET OUR ABSURD POSTAGE INCREASES YOU GET FREE \$2.00 gift certificate with every order no matter how small

RAYLEN ARTS, DEPT. 1  
P.O. Box 3591  
Lantana, FLORIDA 33462

POSTERS AND NOVELTIES

ITEM #	QTY	PRICE
TOTAL ITEMS		
POSTAGE		\$1.00
TOTAL		

add \$1.00 postage to all orders

Name \_\_\_\_\_  
Address \_\_\_\_\_  
City \_\_\_\_\_  
State \_\_\_\_\_ Zip \_\_\_\_\_  
Add applicable sales tax.

## SEX TOYS

**6 99 83 37 79**  
**16 79 38 41 95**  
**106 1.48 28 99 22 99**  
**19 99 14 99 100 1.48**  
**36 99 111 99 43 1.48**  
**1 79 2 79 66 79**

**P145** 11" for big girls only. Uses 3 batteries only \$6.95. The vibes from this giant are long lasting!  
**P148** 4" vibrator (noiseless and cordless) \$1.00.  
**P157** INCREDIBLE SQUIRMIES—Squirmites are the ultimate male substitute. A full 6" with crank on the bottom. Crank flesh like substitute in a squirming rotation. Sit with your eyes closed. You can't tell the difference. Only \$6.95 each.  
**#P278** INTIMATE SEXUAL LUBRICANT. A deep penetrating aerosol spray for intimate lubrication as an aid to love making. Specially suited to the lubrication of rubber sheaths. Mild antiseptic promotes hygiene. \$5.75  
**#P284** EMOTION LOTION. Raspberry flavored oil which imparts an unbelievable warmth to the skin. Very effective. \$3.50

**SUPER DOLLS**  
**P110** DICK DOLL—This is a super doll that inflates to 6 feet. It has an 8" penis plus other incredible openings and features. It's almost the ultimate. \$39.95  
**P111** Jane Doll same as dick doll with obvious differences. 3 openings with vibrating battery operated vagina. Sensational is the word. \$39.95

**3-D POSTER \$2.00 C 23" x 29"**  
**\$2.00 30" x 40" X20**  
**\$2.00 C 30" x 40" X47**

Yes, when you purchase our incredible marital aid catalogue (over 200 devices) for just \$1.00, you get an education plus a FREE \$5.00 certificate. No deal like it anywhere. **BUT YOU MUST STATE YOU ARE 21 years young below. LIMITED OFFER.**

IF BUYING SEX TOYS MAKE SURE YOU SIGN THIS COUPON AND INCLUDE WITH PURCHASE COUPON IT'S A DRAG BUT IT'S NECESSARY TO FILL YOUR ORDER.

Signature \_\_\_\_\_  
I am 21 years young.



New Apostate Exotic Love Potion lets you...

# MAKE LOVE TO ANYONE YOU DESIRE



and have her (or him) at your sexual command, anytime... ANYWHERE!!!

"IMPULSE" was created to sexually stimulate and excite the person you desire. Made from carefully blended erotic spices, "IMPULSE" entices her (or him) to think of love and respond eagerly to your wishes.

If you've ever wanted to have intimate relations with a certain person but could not succeed, then you owe it to yourself to try this unique apostate love formula. IMPULSE mixes easily in all kinds of drinks and is completely safe and tasteless. It can be used on either sex and is mailed in a plain package complete with instructions. If not fully satisfied, return within 10 days for a complete refund.

### ORDER TODAY

Send Cash, Check or Money Order to: NL 576 PROGRESSIVE SALES, DEPT. Box 310, New Rochelle, New York, 10804

- 5 Portion Size only \$4.95
- 12 Portion Size only \$7.95 (Save \$3.93)
- 24 Portion Size only \$11.95 (Save \$11.81)

Name \_\_\_\_\_  
 Address \_\_\_\_\_  
 City \_\_\_\_\_ State \_\_\_\_\_ Zip \_\_\_\_\_

# UNGOGLY!



SANSUI MARANTZ TECHNICS SCOTT SUPERSCOPE SONY SHERWOOD KLH DYNACO PIONEER RECTILINEAR JENSEN AR FAIRFAX KOSS SUPEREX SENNEHEISER CRAIG

MIRACORD GARRARD EMPIRE LENCOR SHURE STANTON ADC CAPITOL TDK AMPEX SCOTCH MAXELL BASF MEMOREX AKAI TEAC WOLLENSAK JILL

### UNGOGLY SAVINGS ON STEREO EQUIPMENT

Write for Our Free Catalog... or Price Quote. Can't Wait?... Call 301 252-6880

Name \_\_\_\_\_  
 Address \_\_\_\_\_  
 City \_\_\_\_\_ State \_\_\_\_\_ Zip \_\_\_\_\_

# STEREO DISCOUNTERS

7A AYLESBURY RD. TIMONIUM, MD. 21093

# Illicit Goods!

(and Goodies)



Giant 64 page catalog

Pipes, papers, clips

240 Comix

Buttons, patches, iron-ons

Only \$1

INSIDE: Hundreds of Comix Books • Buttons • Pipes • Headgear • Patches • & more

Books on drugs

Paraphernalia

refundable with first purchase

Your complete catalog of enlightening and illicit pleasures. 64 pages full of good stuff. Fast reply too! Well worth your buck (refundable with first order). Send coupon and \$1 today to Krupp Mail Order, PO Box 9090, Dept. L-3, Boulder, Colorado 80301.

- Send me your catalog Enclosed is \$1. Dept. L-3

Name \_\_\_\_\_  
 Address \_\_\_\_\_  
 City \_\_\_\_\_ State \_\_\_\_\_ Zip \_\_\_\_\_

# THE MOST SENSUOUS CONDOM IN THE WORLD.

## Näcken™

a Scandinavian best-seller. Combines all the best features of condoms into one sensational condom! Näcken is unique because it is textured to provide the maximum pleasure for both of you. Näcken's delicately ribbed surface gently massages the woman while the contoured formfit provides the greatest sensitivity for the man. Join the Swedish revolution for the optimum in pleasure. Näcken—the condom from Sweden is distributed exclusively by PPA.

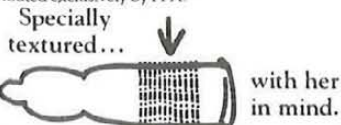

Population Planning Assoc., Dept. DNL 17 105 N. Columbia, Chapel Hill, N.C. 27514 ©1975 PPA

- Please send me:
- Näcken (10 textured condoms) \$5.25
  - Super 100 Home Sampler of 100 assorted condoms (28 different brands) \$25.00
  - Illustrated catalogue 25¢
- Name \_\_\_\_\_  
 Address \_\_\_\_\_  
 City \_\_\_\_\_ State \_\_\_\_\_ Zip \_\_\_\_\_

All orders rushed in a plain unmarked package to insure your privacy. Satisfaction guaranteed or complete refund.



# The Air Bed

by INFLATE-A-BED

From \$49.95

## The Bed You Can Fold Up And Carry In A Bag

### The Most Natural Way To Sleep!

"The Air ued" from Inflate-A-Bed offers you the best of many worlds when it comes to serious contemporary bedding. First off, be prepared for the finest, most naturally pleasant and satisfying night's sleep you've ever had. We've got hundreds of letters attesting to this fact, and literally tens of thousands of people are living this wonderful sleeping experience every night. Sleeping on a cushion of air is as nice as it sounds. "The Air Bed" (which you inflate in minutes with a vacuum cleaner or any air pump) shapes itself to your body almost like cradle-ing it—naturally, on a series of specially patented "air coils," which support your body evenly—and with unheard of flexibility in a mattress. No frame or innerspring is needed, although it will fit into any standard bed frame.

"The Air Bed" is incredibly light and incredibly tough (20 mil Poly Vinyl Chloride). It cleans instantly with soap and water. It deflates in minutes for you to fold up and take with you anywhere—visiting, camping, beach (a dynamite water raft), or storing on a shelf when not in use. It is everything a bed should be—delightfully sensual, highly orthopedic, and conveniently mobile. Try one for 2 weeks.

Please send the following Air Bed(s). If not fully satisfied I can return within 2 weeks for an immediate refund.

- Twin Size @ \$49.95
- Full Size @ \$69.95
- Queen Size @ \$79.95
- King Size @ \$99.95

(Add \$4.95 for shipping and insurance)

- Instead I prefer the Original Inflate-A-Bed (same as above plus a fleeced velveteen finish).
- Twin @ \$59.95
- Full @ \$79.95
- Queen @ \$89.95
- King @ \$114.95

(Add \$4.95 shipping per bed)

- Check or M.O. Enclosed (Ill. residents add 5% sales tax)
- Charge My Credit Card Checked Below:
- American Express
- BankAmericard
- Carte Blanche
- Diners Club
- Master Charge

Credit Card # \_\_\_\_\_  
 Master Charge Bank # \_\_\_\_\_ Exp. Date \_\_\_\_\_  
 Name \_\_\_\_\_  
 Address \_\_\_\_\_  
 City \_\_\_\_\_ State \_\_\_\_\_ Zip \_\_\_\_\_  
 Signature \_\_\_\_\_

Send Coupon To  
**Contemporary Marketing, Inc.**  
 790 Maple Lane, Bensenville, Ill. 60106  
 Call Toll Free: 800-323-2408 Ill. call: 312-595-0451

# Elborne Whippet, Junior

*Mr. Elborne Whippet, Junior, bears a close, nay, precise resemblance to one Jeff Greenfield, a disgruntled politico-journalist of New York City.*

New York—And so they came, as they somehow must, to the hulking, sulking, stone canyons of Gotham, a city in whose proud but infarcted heart generations of lesser breeds lodge thrombotically; and yet, yet, withal, a city whose deepest roots, reaching from the wine cellar of La Menagerie to the fitting room of M. Belladonna's, somehow make of this clamorous, divergent metropolis a crystallized whole that anneals into this Corpulent Mackintosh, this Beirut-on-the-Hudson, this New York.

And they came, these men who would lead us into the twenty-four hundredth month of our nationhood, for that ritual which has become as embedded a part of our political landscape as the factory handshake, the mastectomy, or the X-ray photograph of the bullet wounds: they came for The Auction.

The Auction takes different forms in different climes, for America is many things to many people. In the wealthier regions of Texas, for example, candidates gather at the home of a petroleum executive and pledge to build shelters; whoever promises the biggest, most secure shelter is showered with hundred-dollar bills. (Among the happy-go-lucky Mexicans who serve the food and drink at these gatherings, this ritual is whimsically labeled "*El Grande Felonia*.")

It is in New York, however, where The Auction in its purest form is held as the prospective presidents gather to bid their way into the hearts of the most deeply progressive, morally outraged constituency of our land—the Coalition for New Democratic Priorities.

Reaching, in the CNDP's words, "from the grandest town house on Sutton Place to the meanest beach house in the Hamptons," the Coalition demands that "those who seek our support and our resources must meet the strictest test of progressive fealty." Three years ago, a candidate was disendorsed for shipping a food package to a member

of the Armed Forces ("The fact of filial relationship," Chairman Hyman Trelbaum explained, "cannot excuse this unconscionable support of our already bloated military establishment.>").

Now, on this March Saturday, redolent with regret for winter, yet somehow flushed with the promise of spring, the Coalition gathers at a public school (an institution so beloved by CNDP parents that they shield it from overcrowding by placing all of their offspring in private ones); after a vigorous debate over the presence of an American flag on stage, Chairman Trelbaum begins The Auction.

"The candidates seated behind me have thirty seconds to explain their bids," he says. "The candidate with the highest bid without going over the Gross National Product shall be the winner. We'll begin with Governor Shapp."

"I propose," he says, "\$3,200 for every man, and..."

Boos shake the hall.

"...sorry, every person. In addition, every worker making less than \$22,000 a year shall have a one-week paid vacation."

Two or three handclaps, and a groan of "Scrooge!" are heard.

"Congressman Udall," Trelbaum nods, "we have \$3,200 and a one-week paid vacation."

"You know," the rangy Arizonan begins, "that reminds me of a story—"

"Your bid, Congressman?"

"Right, right. I propose a \$3,800 guaranteed income, air conditioning in all federal prisons, and free child care from birth to age eighteen."

The applause mounts. The bidding quickly increases: Bayh offers \$4,600, free lottery tickets for the blind, and a pair of Gucci loafers to all gay Americans who can prove themselves victims of "aesthetic oppression." Carter's telegraphed offer of \$1,800 is derided ("Peanuts!" one irate member screams), and Henry Jackson's bid for free trips to Israel is ignored.

As the bidding time draws to a close, Fred Harris appears the certain victor. He is offering a guaranteed income of \$6,350, a \$1,000 bonus for dark pigmentation, and one-cent-a-mile rent-a-cars.

Then, suddenly, the doors of the auditorium fly open. There, standing tall, his black-orange hair gleaming like a patent leather loafer in the sun, stands Senator Hubert Humphrey.

The crowd is stunned into silence as this symbol of their past anger, this acolyte of the regrettable War, strides down the center aisle and mounts the stage. As the angry protests begin, he holds up his hands.

"Now, golly gosh-a-minute, folks, before you get all hot and bothered, just hear what an old war-horse has to offer." He steps to the podium and begins the litany.

"First—a guaranteed annual income for every man, woman, and child in America of \$13,500 a year."

Appreciative murmurs are heard.

"Second—for the first two million citizens who sign up for their checks, a free sixty-two piece set of Noritake china.

"Third—an all expense vacation for the entire family, legitimate and otherwise, to Las Vegas, and \$2,500 in federal opportunity money with which to bankroll themselves into a fortune."

There are cheers now, real cheers.

"Fourth—universal medical care, with a personal family physician in residence in the home of every fifth family in the country."

"Give 'em heaven, Hubert," an old-timer shouts. From the rear of the hall, a steadily growing chant of "We want Humphrey!" is building.

"And finally—" Humphrey has the crowd spellbound now, and he lets the silence build to a delicious climax—"I propose a free, universal, federally funded program I call Pharmicare. It has been my dream since my days as a druggist back in Minnesota. It would provide every American a free, unlimited supply of the stimulant, depressant, or hallucinogen of his or her choice!"

The auditorium erupts in cheers; and as the other candidates slink from the stage, the ebullient Minnesotan is lofted high over the shoulders of his one-time adversaries—thus demonstrating anew the vitality and resiliency of our bruised yet vigorous political system, as we stride, with cautious yet renewed faith, into the ten thousand four-hundredth week of our national experience. □

## Blueprint for Flat Frequency Response

In the graph below, frequency response was measured using the CBS 100 Test Record, which sweeps from 20-20,000 Hz. The vertical tracking force was set at one gram. Nominal system capacitance was calibrated to be 300 picofarads and the standard 47K ohm resistance was maintained throughout testing. The upper curves represent the frequency response of the right (red) and left (green) channels. The distance between the upper and lower curves represents separation between the channels in decibels. The inset oscilloscope photo exhibits the cartridge's response to a recorded 1000 Hz square wave indicating its resonant and transient response.

Smooth, flat response from 20-20,000 Hz is the most distinct advantage of Empire's new stereo cartridge, the 2000Z.

The extreme accuracy of its reproduction allows you the luxury of fine-tuning your audio system exactly the way you want it. With the 2000Z, you can exaggerate highs, accentuate lows or leave it flat. You can make your own adjustments without being tied to the dips and peaks characteristic of most other cartridges.

For a great many people, this alone is reason for owning the Z. However, we engineered this cartridge to give you more. And it does. Tight channel balance, wide separation, low tracking force and excellent tracking ability combine to give you total performance.

See for yourself in the specifications below, then go to your audio dealer for a demonstration you won't soon forget.

The Empire 2000Z.

Already your system sounds better.

**Frequency Response**—20 to 20K Hz  $\pm$  1 db using CBS 100 test record  
**Recommended Tracking Force**— $\frac{3}{4}$  to 1 $\frac{1}{4}$  grams  
 (specification given using 1 gram VTF)

**Separation**—20 db 20 Hz to 500 Hz  
 30 db 500 Hz to 15K Hz  
 25 db 15K Hz to 20K Hz

**I.M. Distortion**—(RCA 12-5-105) less than .08% .2KHz to 20K Hz @ 3.54 cm/sec

**Stylus**—0.2 x 0.7 mil diamond

**Effective Tip Mass**—0.2 mg

**Compliance**—lateral 30 X 10<sup>-6</sup> cm/dyne  
 vertical 30 X 10<sup>-6</sup> cm/dyne

**Tracking Ability**—0.9 grams for 38 cm per sec @ 1000 Hz  
 0.8 grams for 30 cm per sec @ 400 Hz

**Channel Balance**—within  $\frac{3}{4}$  db @ 1 kHz

**Tracking Angle**—20°

**Recommended Load**—47 K Ohms

**Nominal Total System Capacitance** required 300 pF

**Output**—3mv @ 3.5 cm per sec using CBS 100 test record

**D.C. Resistance**—1100 Ohms

**Inductance**—675 mH

**Number and Type of Poles**—16 Laminations in a 4 pole configuration

**Number of Coils**—4 (1 pair/channel—hum cancelling)

**Number of Magnets**—3 positioned to eliminate microphonics

**Type of Cartridge**—Fully shielded, moving iron

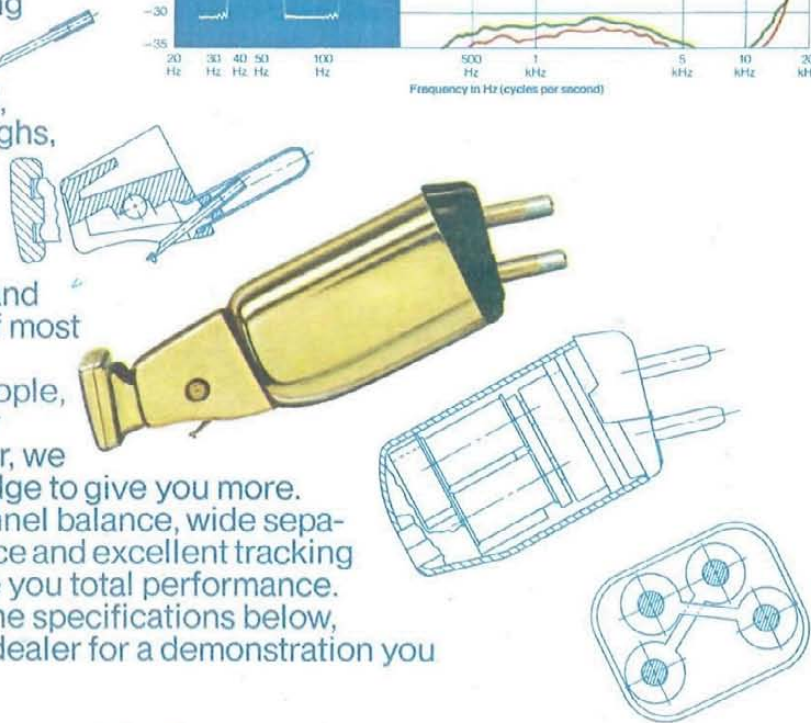
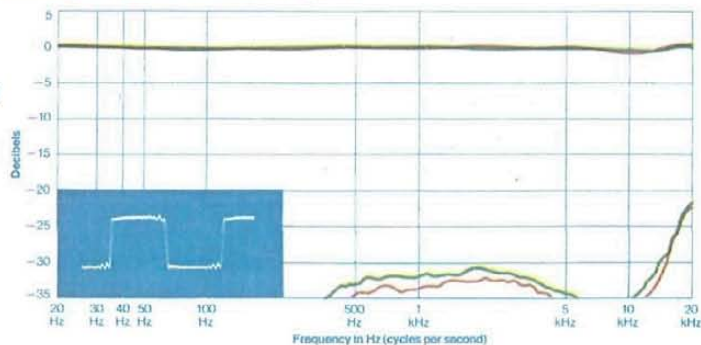

Don't settle for  
a halfway menthol.

Come all the way  
up to KOOL.  
Pure menthol and  
the taste of extra  
coolness have  
made KOOL America's  
#1 selling  
menthol.



Warning: The Surgeon General Has Determined  
That Cigarette Smoking Is Dangerous to Your Health.